

Proposal Basic Information

Proposal File No.	MNNP/BP/0032/W04/2024
Owner Name	Sarita Devi
Khata No	18
Plot No	303
Village Name	Sudma Bariya
Use	Residential
SubUse	Bungalow/ Dwelling / Non Apartment

FAR & Tenement Details (Table 4c-1)

Building	No. of Same Bldg	Total Built Up Area (Sq.mt.)	Proposed FAR Area (Sq.mt.) Resi.	Total FAR Area (Sq.mt.)	Total Consumed Additional FAR Area (Sq.mt.)	Tnmt (No.)
A (RESIDENTIAL)	1	81.15	81.15	81.15	81.15	01
Grand Total :	1	81.15	81.15	81.15	81.15	01

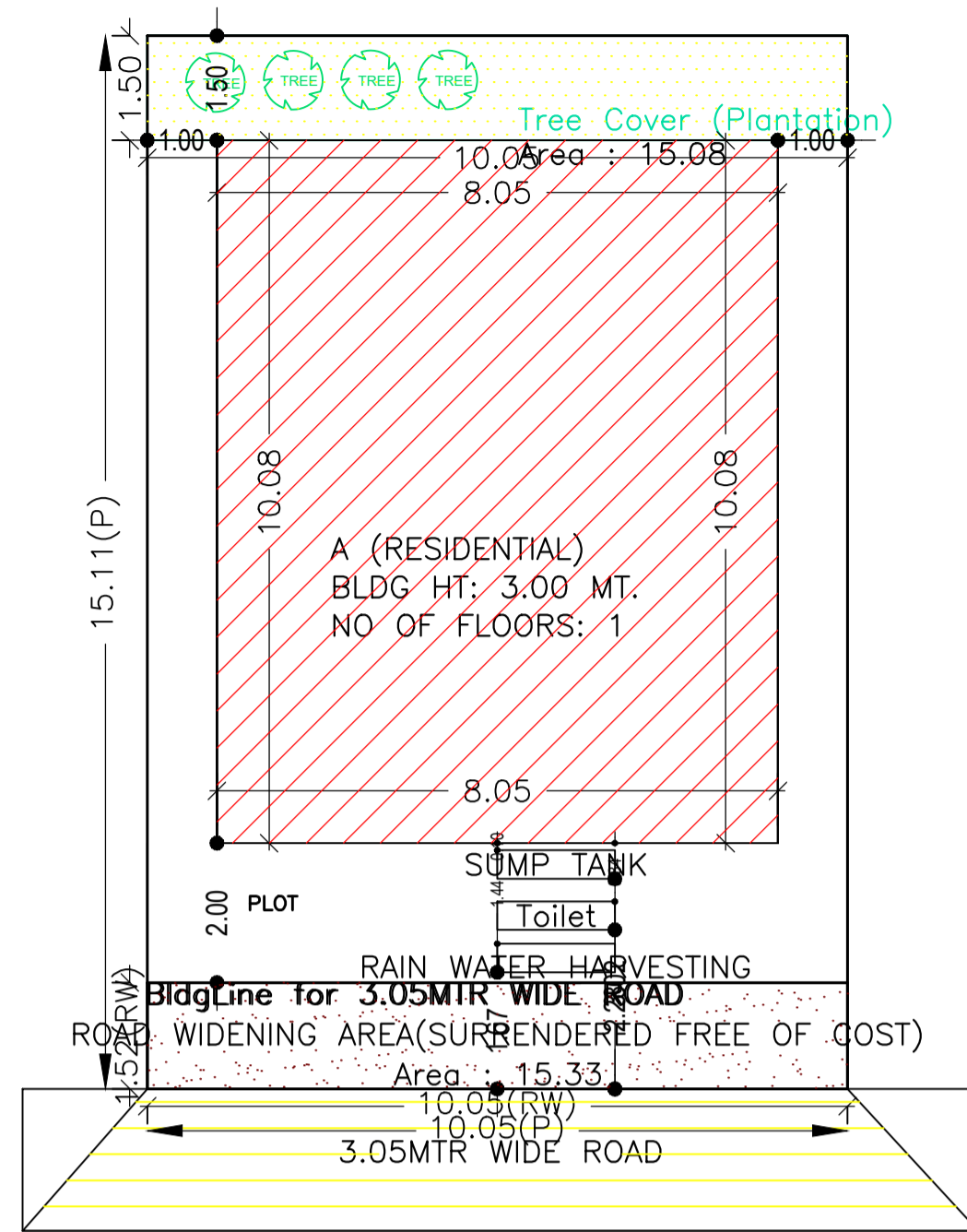

SITE PLAN

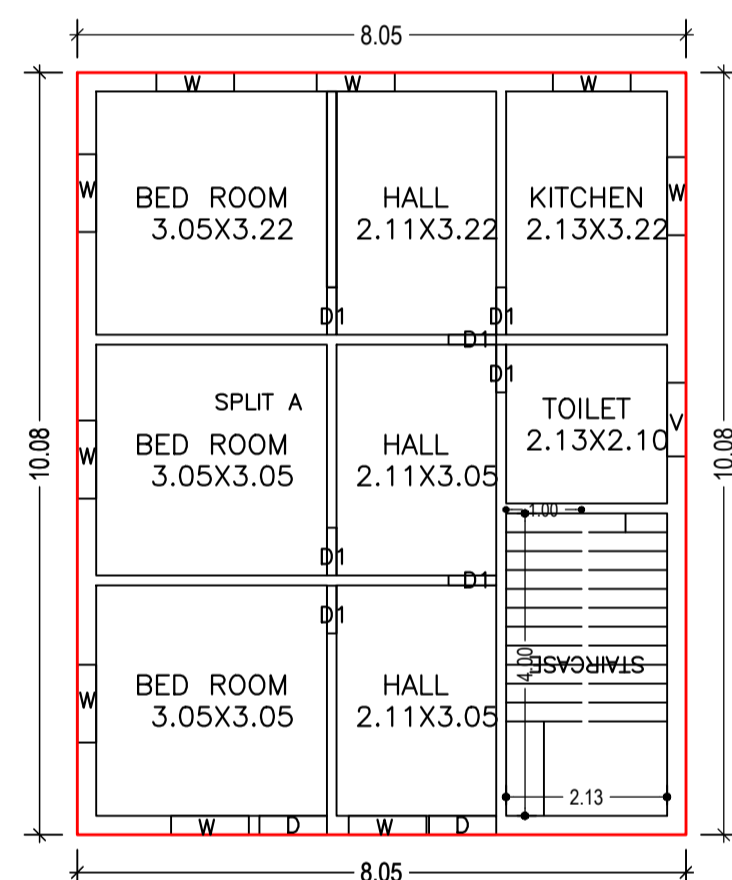

GROUND FLOOR PLAN (Proposed) (SCALE 1:100)

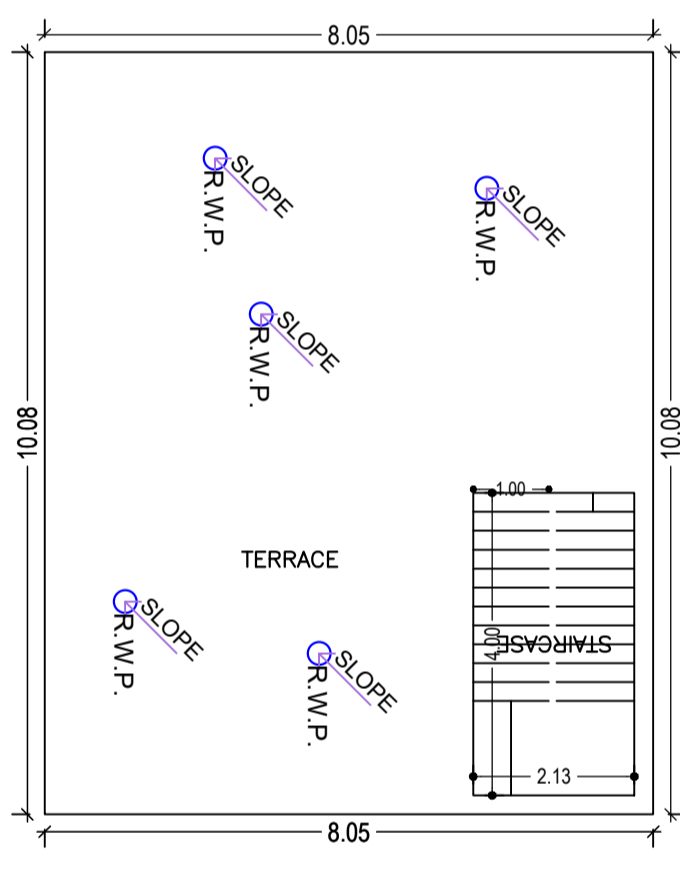

TERRACE FLOOR PLAN (SCALE 1:100)

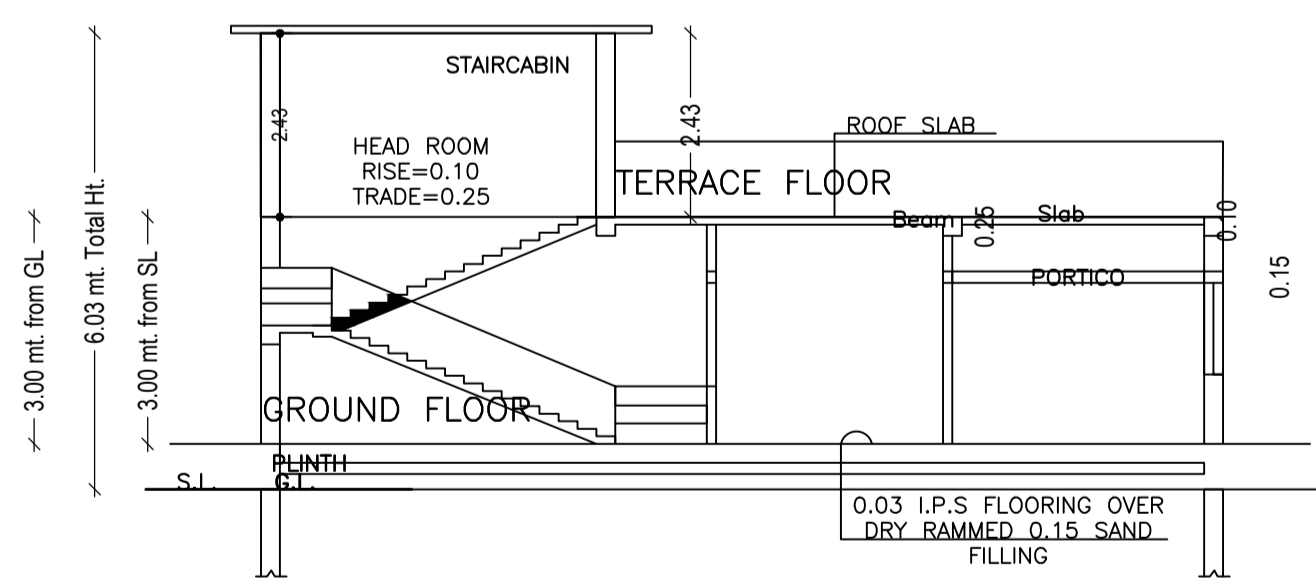

SECTION ON-XX

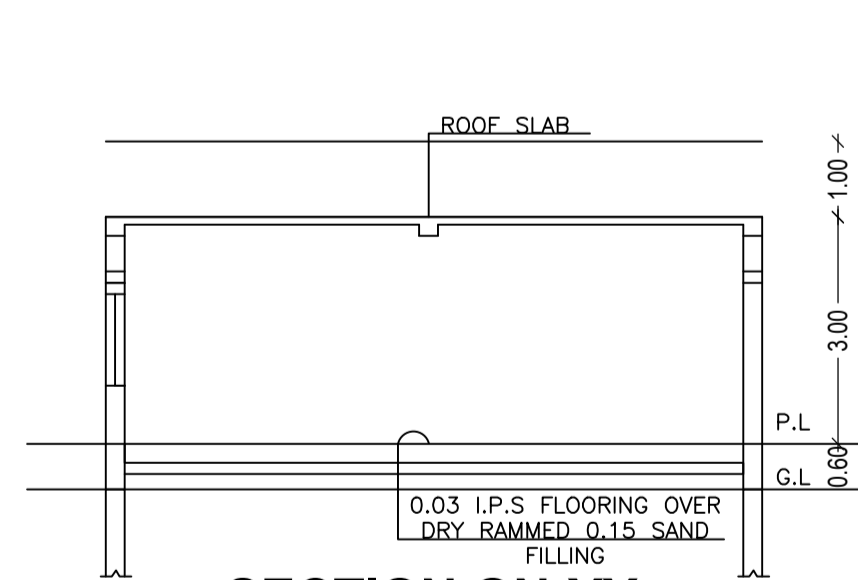

SECTION ON-YY

Building :A (RESIDENTIAL)

Floor Name	Total Built Up Area (Sq.mt.)	Proposed FAR Area (Sq.mt.) Resi.	Total FAR Area (Sq.mt.)	Total Consumed Additional FAR Area (Sq.mt.)	Tnmt (No.)
Ground Floor	81.15	81.15	81.15	81.15	01
Terrace Floor	0.00	0.00	0.00	0.00	00
Total :	81.15	81.15	81.15	81.15	01

SCHEDULE OF DOOR:

BUILDING NAME	NAME	LENGTH	HEIGHT	NOS
A (RESIDENTIAL)	D1	0.63	2.10	07
A (RESIDENTIAL)	D	0.89	2.10	02

SCHEDULE OF WINDOW/VENTILATION:

BUILDING NAME	NAME	LENGTH	HEIGHT	NOS
A (RESIDENTIAL)	V	0.97	0.60	01
A (RESIDENTIAL)	W	1.03	1.20	09

UnitBUA Table for Building :A (RESIDENTIAL)

FLOOR	Name	UnitBUA Type	UnitBUA Area	Carpet Area	No. of Rooms	No. of Tenement
GROUND FLOOR	SPLIT A	FLAT	71.03	70.70	8	1
Total:	-	-	71.03	70.70	8	1

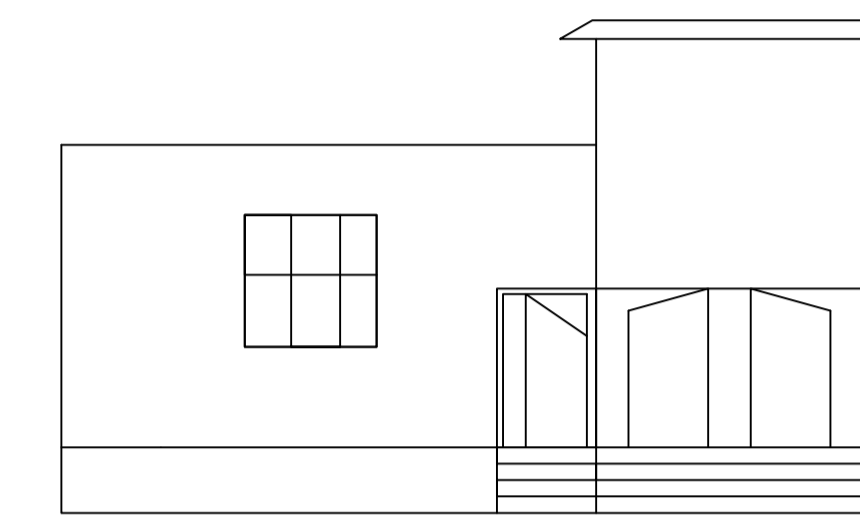

FRONT ELEVATION

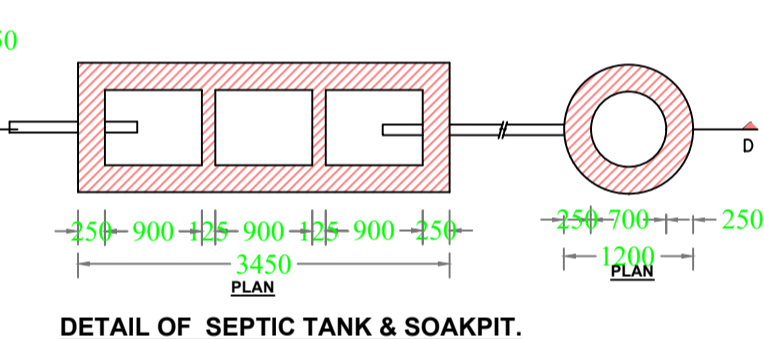
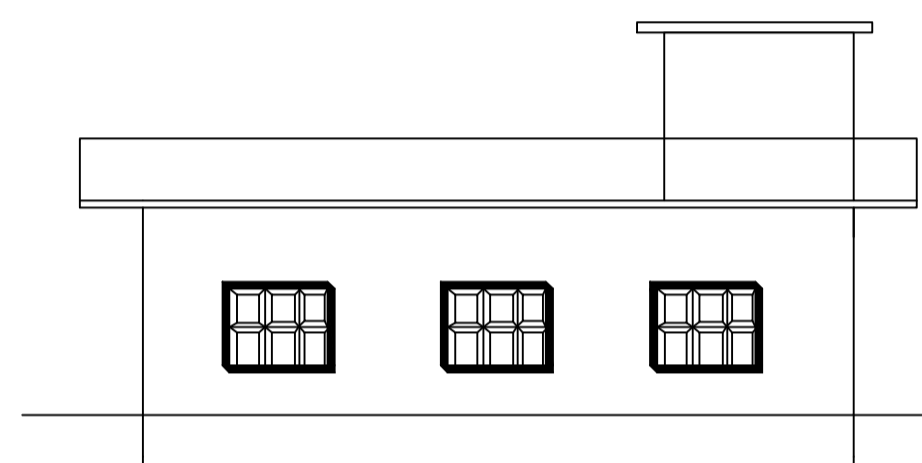

DETAIL OF SEPTIC TANK & SOAKPIT.

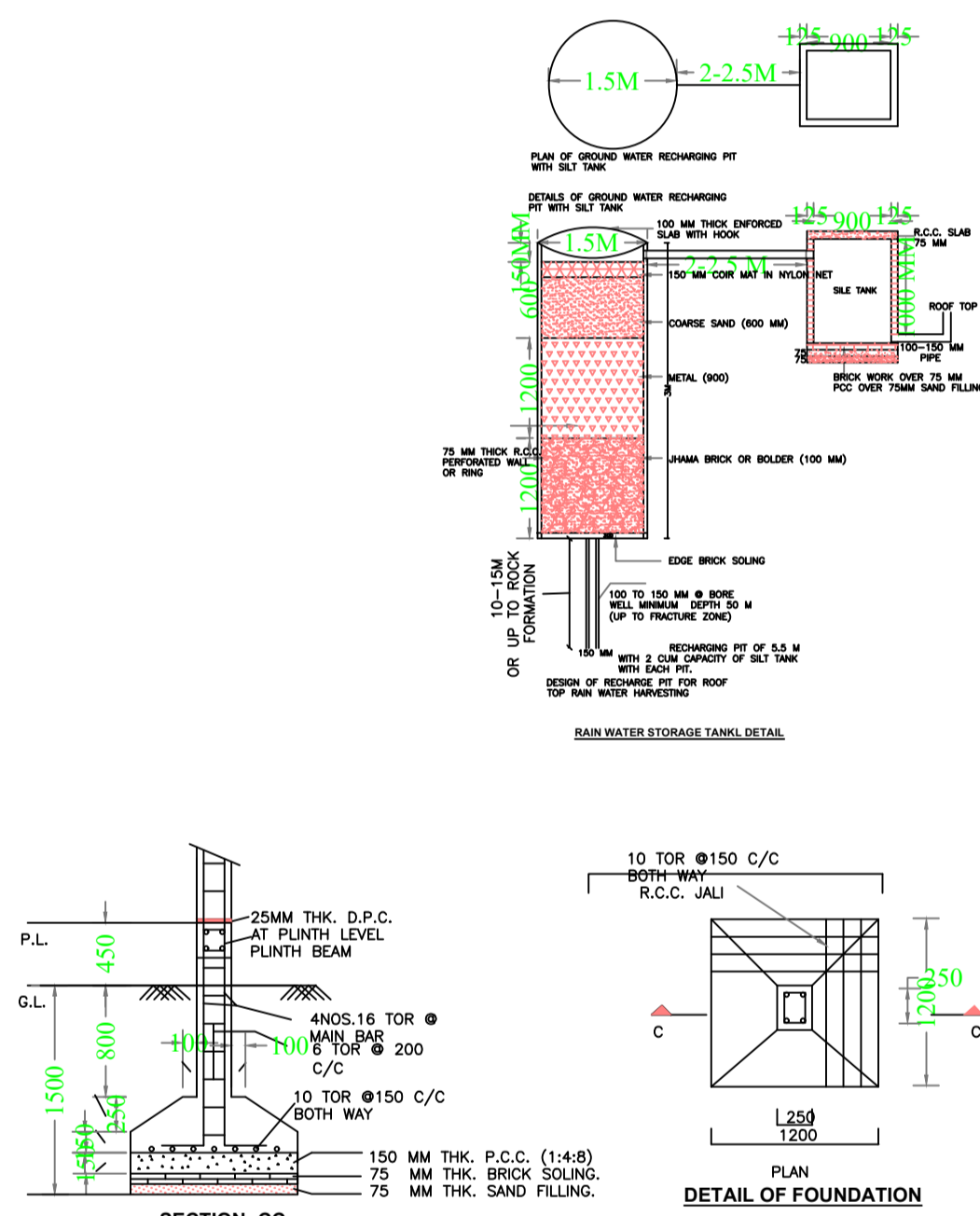

STRUCTURAL DETAIL

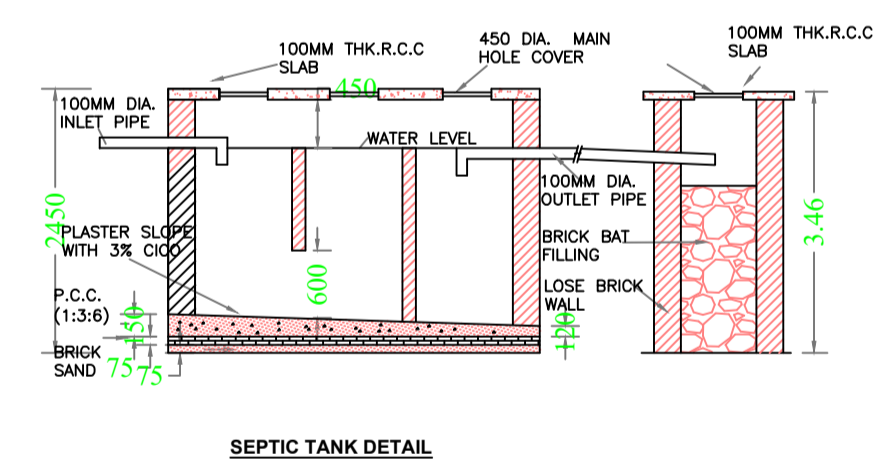

SEPTIC TANK DETAIL

AREA STATEMENT		VERSION NO. : 1.0.68
MEDINAGAR MUNICIPAL CORPORATION		VERSION DATE: 16/10/2020
PROJECT DETAIL:		
Region : JHARKHAND URBAN	Plot Use: Residential	
LOCAL BODIES	District PALANJU	Plot SubUse: Bungalow/ Dwelling / Non Apartment
Authority: MEDINAGAR MUNICIPAL CORPORATION	PlotNearbyReligiousStructure: NA	
Inward No: MNNP/BP/0032/W04/2024	Plot/SubPlot No: 303	
Application Type: General Proposal	North: -	
Project Type: Building Permission	South: -	
Nature of Development: New	East: -	
Location of Development Area: New	West: -	
AREA DETAILS:		
AREA OF PLOT (Minimum)	(A)	SQ.MT. 151.81
Deduction for NetPlot Area		15.33
Surrender Free of Cost		15.33
NET AREA OF PLOT(Gross Plot Area - Deduction from Gross Plot area)	(A-Deductions)	136.48
Deduction for Balance Plot Area(from Gross Plot Area)		
Surrender Free of Cost		15.33
Common Plot		15.08
Total		30.41
BALANCE AREA OF PLOT(Net Plot Area - Recreational/Amenity space)	(A-Deductions)	121.41
PLOT AREA FOR COVERAGE(Net Plot Area)	(A-Deductions)	136.48
Plot Area for FAR (Net Plot Area + Road Widening Area)	(A-Deductions)	151.81
COVERAGE CHECK		
Permissible Coverage area (70.00 %)		95.54
Proposed Coverage Area (59.46 %)		81.15
Total Prop. Coverage Area (59.46 %)		81.15
Balance coverage area (10.54 %)		14.39
FAR CHECK		
Perm. FAR Area (1.200)		182.17
Total Perm. FAR area		182.17
Residential FAR		81.15
Proposed FAR Area		81.15
Total Proposed FAR Area		81.15
Consumed FAR (Factor)		0.53
Balance FAR Area		101.02
BUILT UP AREA CHECK		
Total Proposed BuiltUp Area		81.15
ARCHITECT (Regd)		RANJIT KUMAR
ENGINEER (Regd)		
SUPERVISOR (Regd)		
OWNER (Regd)		Sarita Devi
DEVELOPMENT AUTHORITY		LOCAL BODY

COLOR INDEX	
PLOT BOUNDARY	Black
ABUTTING ROAD	Red
PROPOSED CONSTRUCTION	Green
COMMON PLOT	Yellow
ROAD WIDENING AREA	Blue
EXISTING (To be retained)	Light Blue
EXISTING (To be demolished)	White

Buildingwise Floor FAR Details

Floor Name	Building Name A (RESIDENTIAL)		Total	
	Proposed Built Up Area (Sq.mt.)	Proposed FAR Area (Sq.mt.)	Total Proposed Built Up Area (Sq.mt.)	Total FAR Area (Sq.mt.)
Ground Floor	81.15	81.15	81.15	81.15
Terrace Floor	0.00	0.00	0.00	0.00
Total :	81.15	81.15	81.15	81.15

Building USE/SUBUSE Details

Building Name	Building Use	Building SubUse	Building Structure
A (RESIDENTIAL)	Residential	Bungalow/ Dwelling / Non Apartment	Non-Highrise

LTP NAME AND SIGNATURE	STRUCTURAL ENG'S NAME AND SIGNATURE	BUILDER NAME AND SIGNATURE	DIGITAL SIGNATURE
RANJIT KUMAR MNNP/ENG/0001/2016			