

Proposal Basic Information	
Proposal File No.	MNNP/BP/0022/W07/2024
Owner Name	Prem Lata Devi
Khata No	365
Plot No	495
Village Name	Redma
Use	Residential
SubUse	Bungalow/ Dwelling / Non Apartment

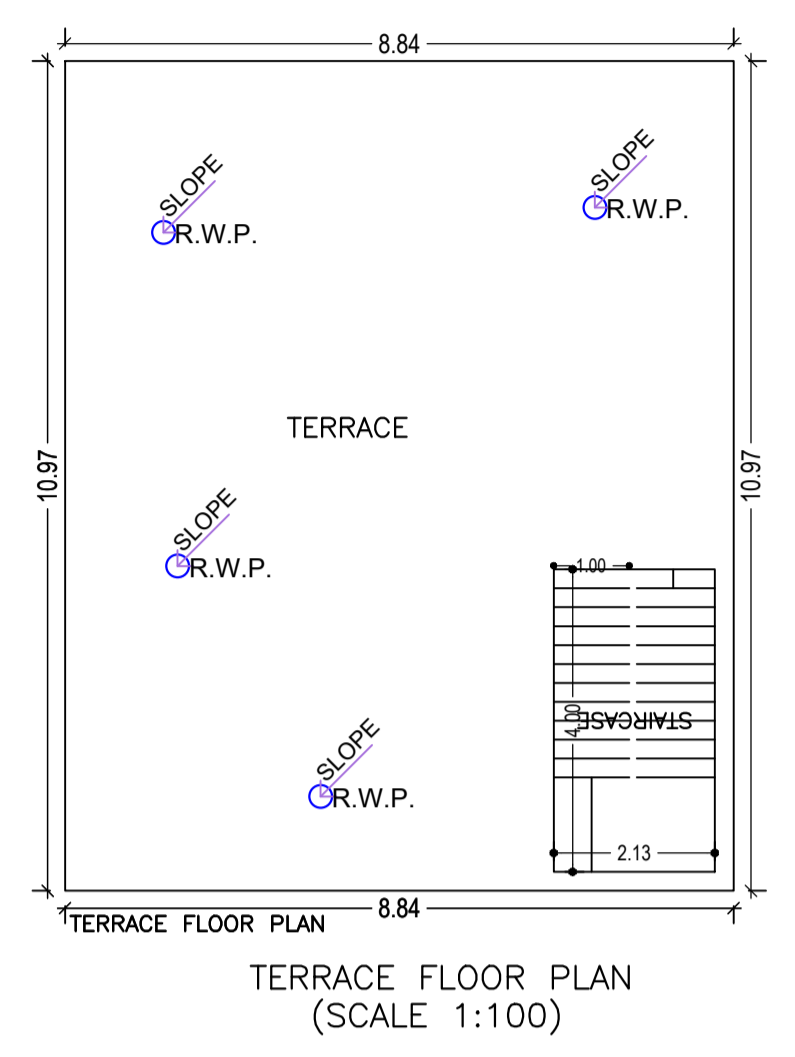
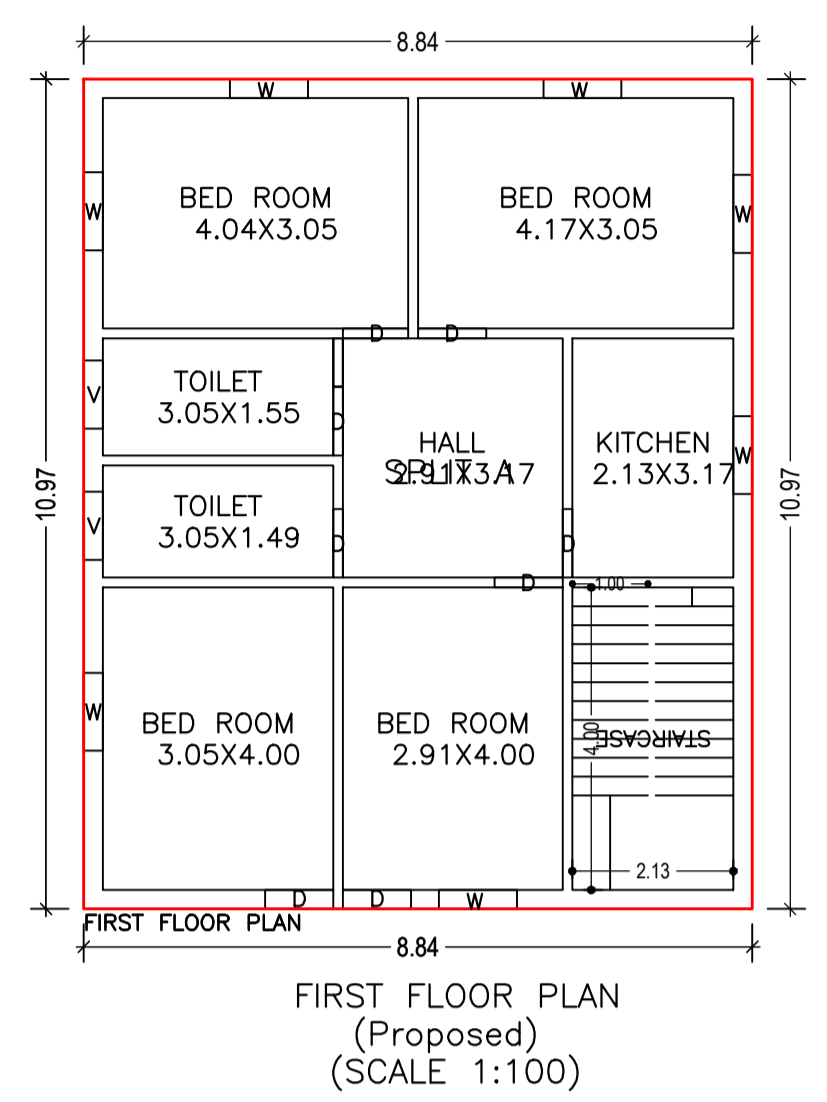
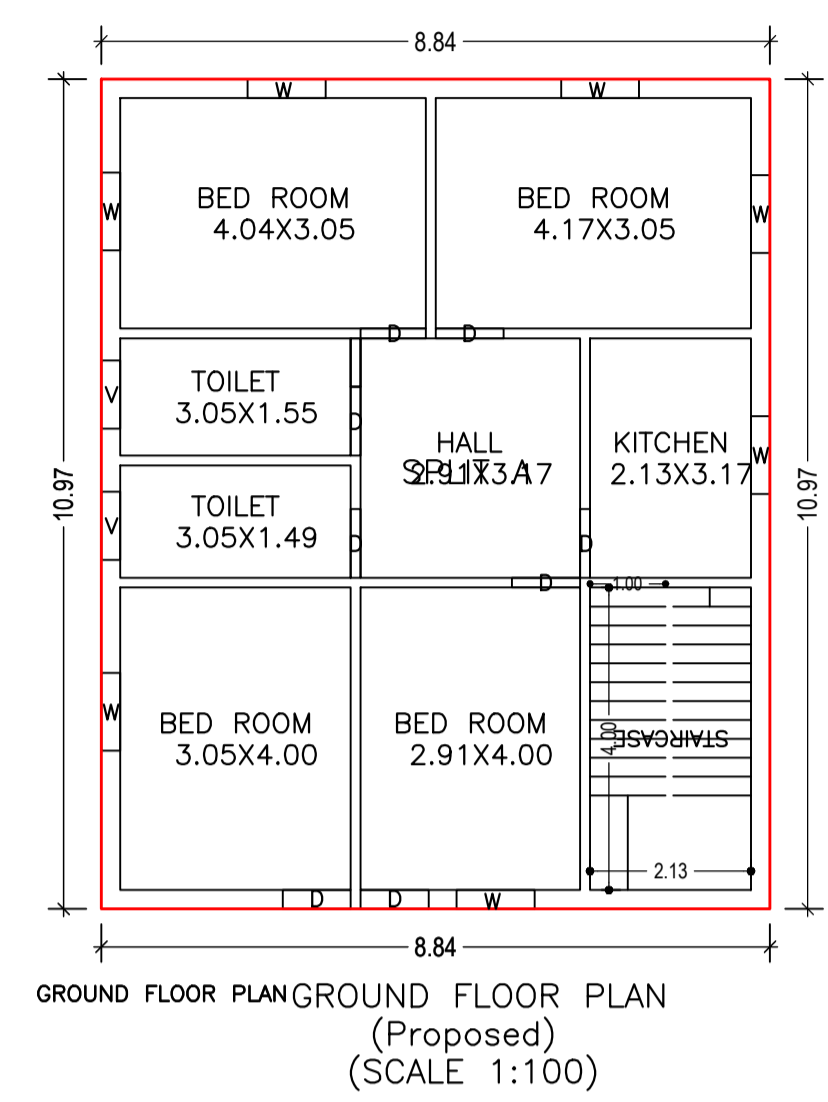
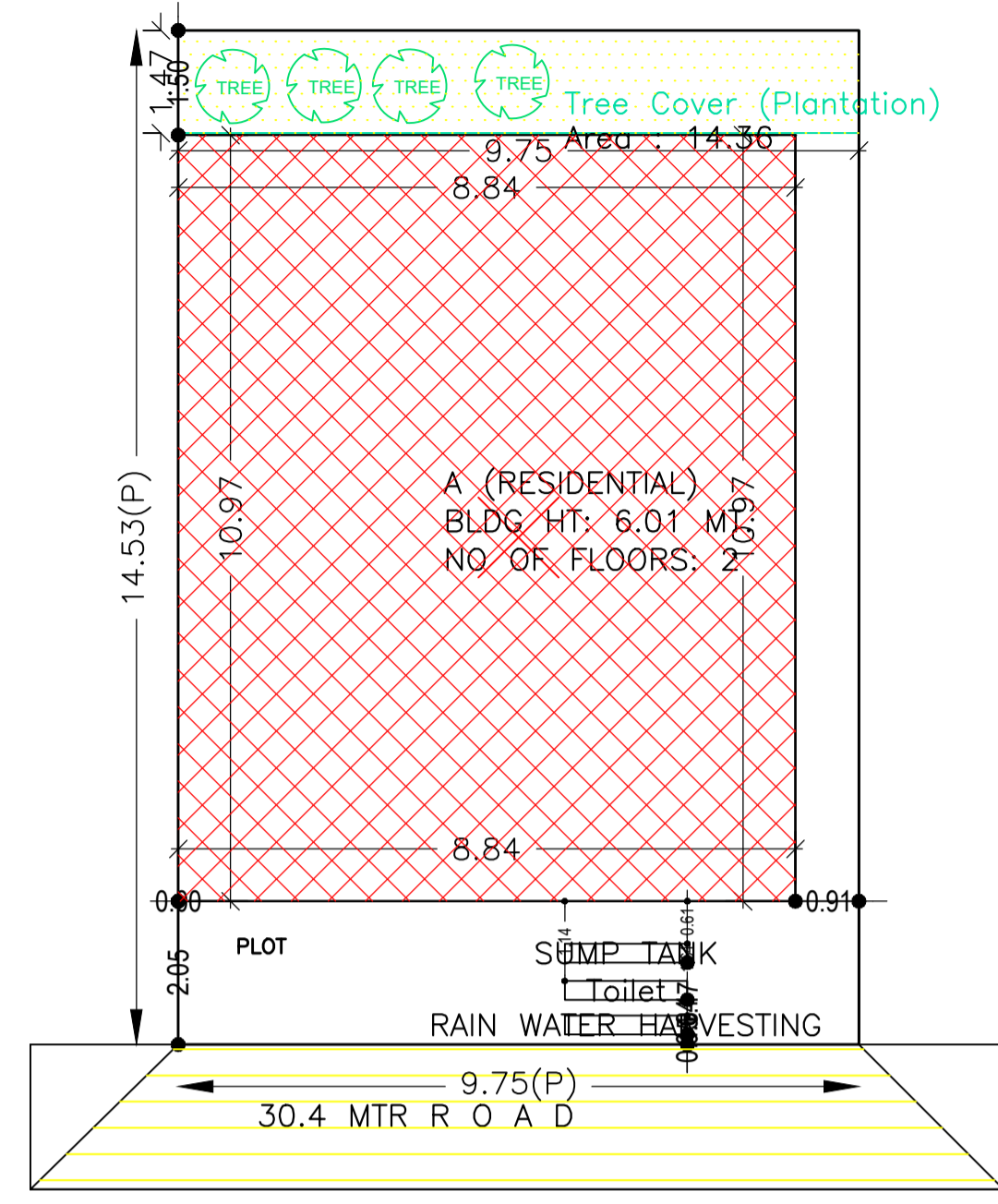

SITE PLAN

Building :A (RESIDENTIAL)

Floor Name	Total Built Up Area (Sq.mt.)	Proposed FAR Area (Sq.mt.) Resi.	Total FAR Area (Sq.mt.)	Total Consumed Additional FAR Area (Sq.mt.)	Tnmt (No.)
Ground Floor	97.05	97.05	97.05	97.05	01
First Floor	97.05	97.05	97.05	97.05	00
Terrace Floor	0.00	0.00	0.00	0.00	00
Total :	194.10	194.10	194.10	194.10	01
Total Number of Same Buildings :	1				
Total :	194.10	194.10	194.10	194.10	01

SCHEDULE OF DOOR:

BUILDING NAME	NAME	LENGTH	HEIGHT	NOS
A (RESIDENTIAL)	D	0.86	2.10	02
A (RESIDENTIAL)	D	0.90	2.10	08
A (RESIDENTIAL)	D	0.91	2.10	06

SCHEDULE OF WINDOW/VENTILATION:

BUILDING NAME	NAME	LENGTH	HEIGHT	NOS
A (RESIDENTIAL)	V	0.90	0.60	04
A (RESIDENTIAL)	W	1.03	1.20	14

UnitBUA Table for Building :A (RESIDENTIAL)

FLOOR	Name	UnitBUA Type	UnitBUA Area	Carpert Area	No. of Rooms	No. of Tenement
GROUND FLOOR PLAN	SPLIT A	FLAT	173.87	173.70	8	1
FIRST FLOOR PLAN	SPLIT A	FLAT	0.00	0.00	8	0
Total:	-	-	173.87	173.70	16	1

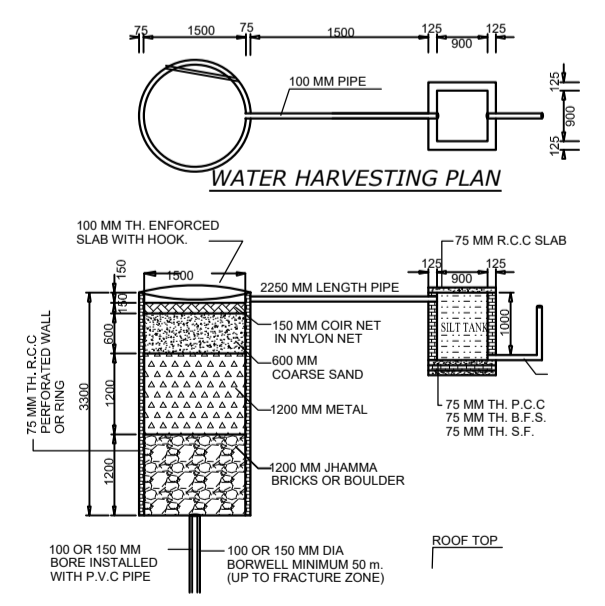
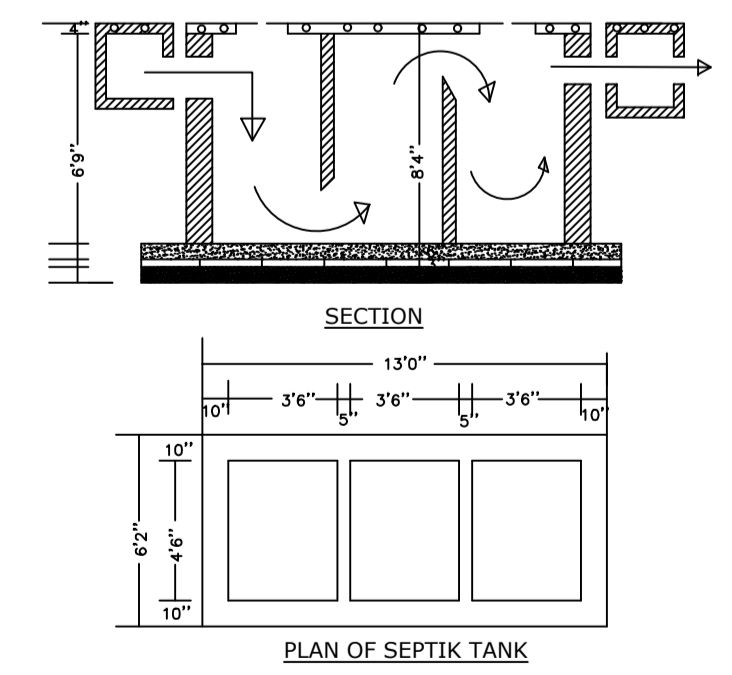
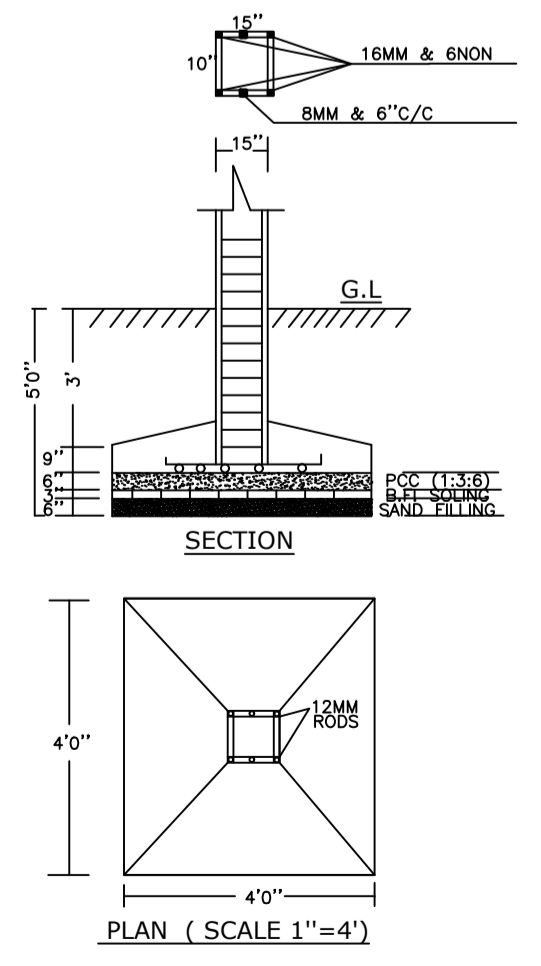
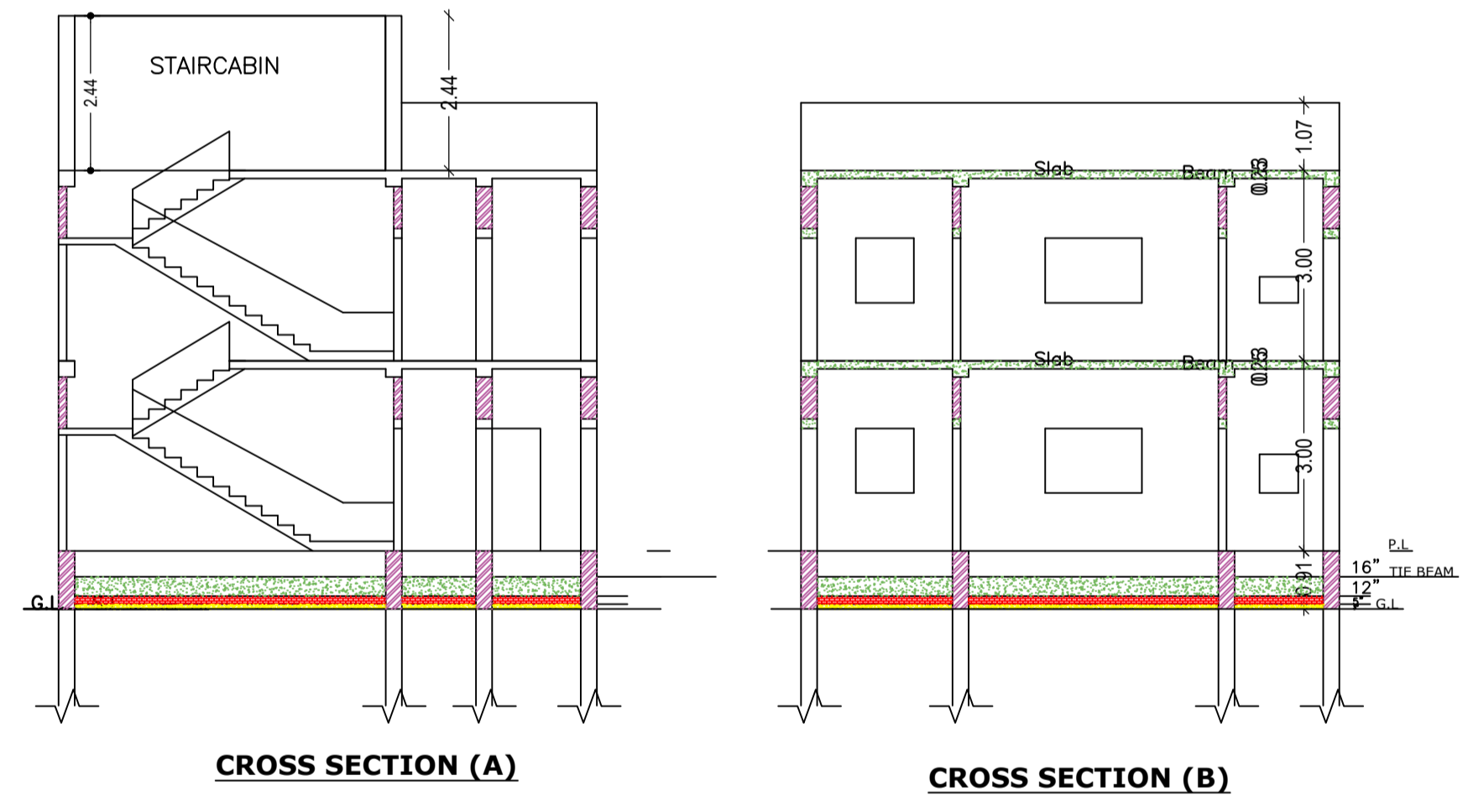

AREA STATEMENT		VERSION NO. : 1.0.68	SQ.MT.
MEDININAGAR MUNICIPAL CORPORATION		VERSION DATE: 16/10/2020	
PROJECT DETAIL:			
Region: JHARKHAND URBAN	Plot Use: Residential		
LOCAL BODIES: District: PALAMU	Plot SubUse: Bungalow/ Dwelling / Non Apartment		
Authority: MEDININAGAR MUNICIPAL CORPORATION	PlotNearby/ReligiousStructure: NA		
Inward No: MNNP/BP/0022/W07/2024	Plot/SubPlot No: 495		
Application Type: General Proposal	North: -		
Project Type: Building Permission	South: -		
Nature of Development: New	East: -		
Location of Development Area: New Area:	West: -		
AREA DETAILS:			
AREA OF PLOT (Minimum)	(A)		141.63
NET AREA OF PLOT(Gross Plot Area - Deduction from Gross Plot area)	(A-Deductions)		141.63
Deduction for Balance Plot Area(from Gross Plot Area)			
Common Plot			14.36
Total			14.36
BALANCE AREA OF PLOT(Net Plot Area - Recreational/Amenity space)	(A-Deductions)		127.27
PLOT AREA FOR COVERAGE(Net Plot Area)	(A-Deductions)		141.63
Plot Area for FAR (Net Plot Area + Road/Widening Area)	(A-Deductions)		141.63
COVERAGE CHECK			
Permissible Coverage area (70.00 %)			99.14
Proposed Coverage Area (68.52 %)			97.05
Total Prop. Coverage Area (68.52 %)			97.05
Balance coverage area (1.48 %)			2.09
FAR CHECK			
Perm. FAR Area (2.500)			354.08
Total Perm. FAR area			354.08
Residential FAR			194.10
Proposed FAR Area			194.10
Total Proposed FAR Area			194.10
Consumed FAR (Factor)			1.37
Balance FAR Area			159.98
BUILT UP AREA CHECK			
Total Proposed BuiltUp Area			194.10
ARCHITECT (Regd)		RANJIT KUMAR	
ENGINEER (Regd)			
SUPERVISOR (Regd)			
OWNER (Regd)		Prem Lata Devi	
DEVELOPMENT AUTHORITY		LOCAL BODY	

COLOR INDEX	
PLOT BOUNDARY	Black
ABUTTING ROAD	Green
PROPOSED CONSTRUCTION	Red
COMMON PLOT	Yellow
ROAD WIDENING AREA	Blue
EXISTING (To be retained)	Light Blue
EXISTING (To be demolished)	Light Yellow

Buildingwise Floor FAR Details

Floor Name	Building Name		Total	
	Proposed Built Up Area (Sq.mt.)	Proposed FAR Area (Sq.mt.)	Total Proposed Built Up Area (Sq.mt.)	Total FAR Area (Sq.mt.)
Ground Floor	97.05	97.05	97.05	97.05
First Floor	97.05	97.05	97.05	97.05
Terrace Floor	0.00	0.00	0.00	0.00
Total :	194.10	194.10	194.10	194.10

Building USE/SUBUSE Details

Building Name	Building Use	Building SubUse	Building Structure
A (RESIDENTIAL)	Residential	Bungalow/ Dwelling / Non Apartment	Non-Highrise

FAR & Tenement Details (Table 4c-1)

Building	No. of Same Bldg	Total Built Up Area (Sq.mt.)	Proposed FAR Area (Sq.mt.) Resi.	Total FAR Area (Sq.mt.)	Total Consumed Additional FAR Area (Sq.mt.)	Tnmt (No.)
A (RESIDENTIAL)	1	194.10	194.10	194.10	194.10	01
Grand Total :	1	194.10	194.10	194.10	194.10	01

LTP NAME AND SIGNATURE	STRUCTURAL ENG'S NAME AND SIGNATURE	BUILDER NAME AND SIGNATURE	DIGITAL SIGNATURE
RANJIT KUMAR MNNP/ENG/0001/2016			