

Building :A (BUILDING)

Floor Name	Total Built Up Area (Sq.mt.)	Proposed FAR Area (Sq.mt.) Resi.	Total FAR Area (Sq.mt.)	Total Consumed Additional FAR Area (Sq.mt.)	Tnmt (No.)
Ground Floor	47.04	47.04	47.04	47.04	01
First Floor	47.04	47.04	47.04	47.04	00
Terrace Floor	0.00	0.00	0.00	0.00	00
Total :	94.08	94.08	94.08	94.08	01
Total Number of Same Buildings	1				
Total :	94.08	94.08	94.08	94.08	01

SCHEDULE OF DOOR:

BUILDING NAME	NAME	LENGTH	HEIGHT	NOS
A (BUILDING)	D	0.90	2.10	10

SCHEDULE OF WINDOW/VENTILATION:

BUILDING NAME	NAME	LENGTH	HEIGHT	NOS
A (BUILDING)	W	1.20	1.20	08

UnitBUA Table for Building :A (BUILDING)

FLOOR	Name	UnitBUA Type	UnitBUA Area	Carpet Area	No. of Rooms	No. of Tenement
GROUND FLOOR PLAN	SPLIT A	FLAT	76.56	76.52	5	1
FIRST FLOOR PLAN	SPLIT A	FLAT	0.00	0.00	5	0
Total:	-	-	76.56	76.52	10	1

FAR & Tenement Details (Table 4c-1)

Building	No. of Same Bldg	Total Built Up Area (Sq.mt.)	Proposed FAR Area (Sq.mt.) Resi.	Total FAR Area (Sq.mt.)	Total Consumed Additional FAR Area (Sq.mt.)	Tnmt (No.)
A (BUILDING)	1	94.08	94.08	94.08	94.08	01
Grand Total :	1	94.08	94.08	94.08	94.08	01

Proposal Basic Information

Proposal File No.	MNNP/BP/0060/W19/2024
Owner Name	Pavitra Pranav
Khata No	102
Plot No	784
Village Name	Redma
Use	Residential
SubUse	Bungalow/ Dwelling / Non Apartment

AREA STATEMENT
MEDININAGAR MUNICIPAL CORPORATION
VERSION NO.: 1.0.69
VERSION DATE: 16/10/2020

AREA DETAILS		SQ.MT.
AREA OF PLOT (Minimum)	(A)	90.94
Deduction for NetPlot Area		
Surrender Free of Cost		11.34
Total		11.34
NET AREA OF PLOT(Gross Plot Area - Deduction from Gross Plot area)	(A-Deductions)	79.60
Deduction for Balance Plot Area(from Gross Plot Area)		
Surrender Free of Cost		11.34
Common Plot		10.43
Total		21.77
BALANCE AREA OF PLOT(Net Plot Area - Recreational/Amenity space)	(A-Deductions)	69.16
PLOT AREA FOR COVERAGE(Net Plot Area)	(A-Deductions)	79.60
Plot Area for FAR (Net Plot Area + Road/Widening Area)	(A-Deductions)	90.94
COVERAGE CHECK		
Permissible Coverage area (70.00 %)		55.72
Proposed Coverage Area (59.10 %)		47.04
Total Prop. Coverage Area (59.1 %)		47.04
Balance coverage area (10.90 %)		8.68
FAR CHECK		
Perm. FAR Area (1.200)		109.13
Total Perm. FAR area		109.13
Residential FAR		94.07
Proposed FAR Area		94.07
Total Proposed FAR Area		94.07
Consumed FAR (Factor)		1.03
Balance FAR Area		15.06
BUILT UP AREA CHECK		
Total Proposed BuiltUp Area		94.08
ARCHITECT (Regd)	SHAIENDRA KUMAR VERMA	
ENGINEER (Regd)		
SUPERVISOR (Regd)		
OWNER (Regd)	Pavitra Pranav	
DEVELOPMENT AUTHORITY	LOCAL BODY	

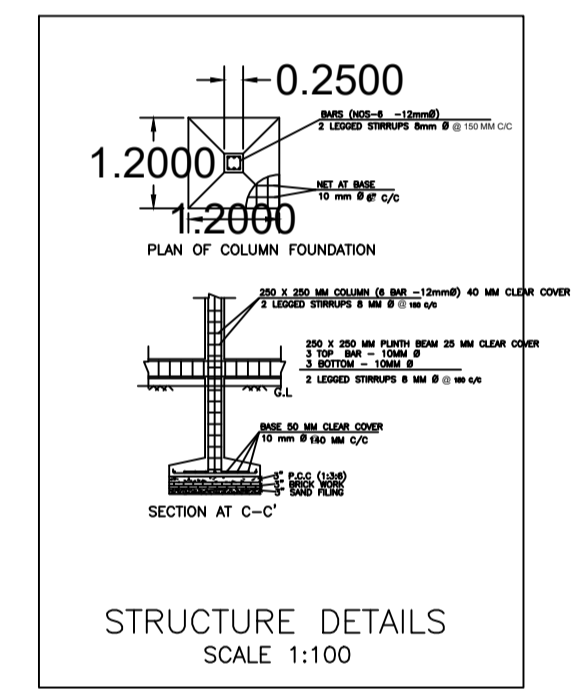
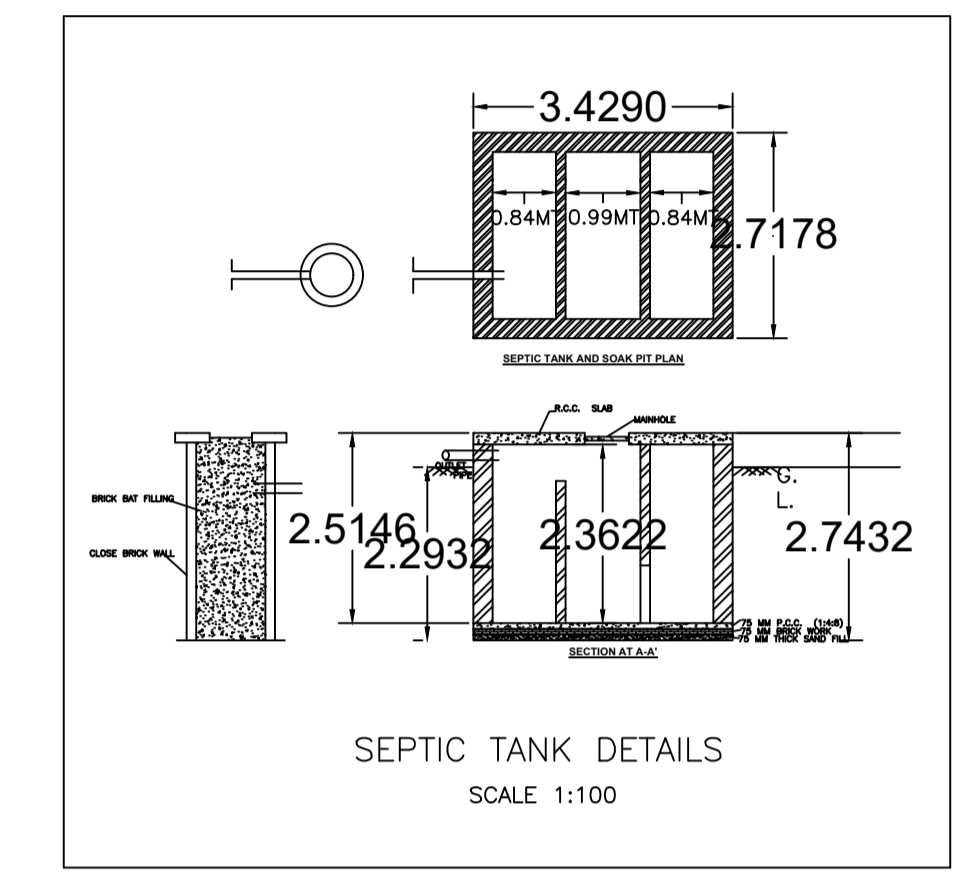
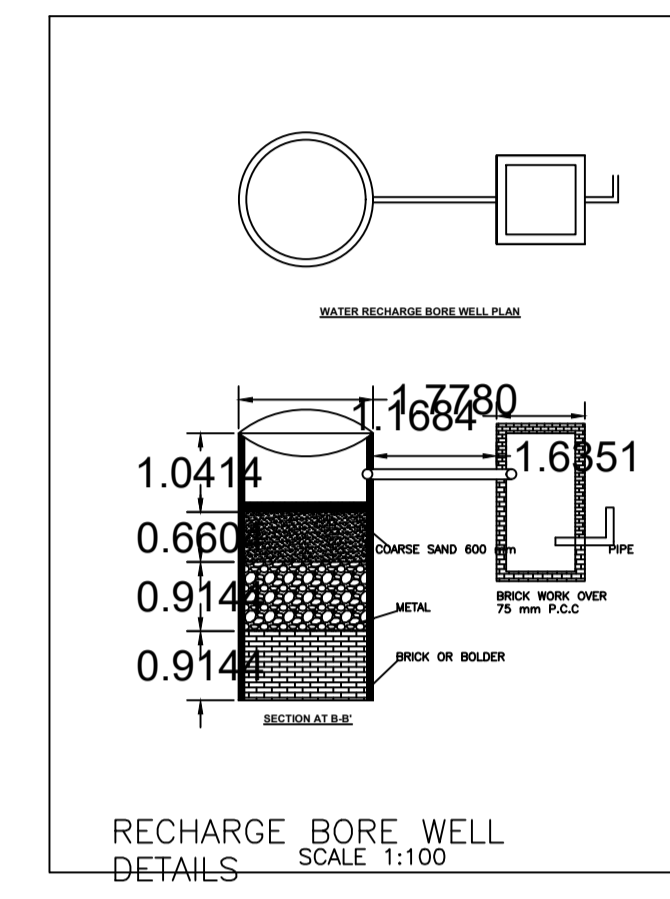

COLOR INDEX

PLOT BOUNDARY	Black
ABUTTING ROAD	Green
PROPOSED CONSTRUCTION	Red
COMMON PLOT	Yellow
ROAD WIDENING AREA	Blue
EXISTING (To be retained)	Orange
EXISTING (To be demolished)	White

Buildingwise Floor FAR Details

Floor Name	Building Name A (BUILDING)		Total	
	Proposed Built Up Area (Sq.mt.)	Proposed FAR Area (Sq.mt.)	Total Proposed Built Up Area (Sq.mt.)	Total FAR Area (Sq.mt.)
Ground Floor	47.04	47.04	47.04	47.04
First Floor	47.04	47.04	47.04	47.04
Terrace Floor	0.00	0.00	0.00	0.00
Total :	94.08	94.08	94.08	94.08

Building USE/SUBUSE Details

Building Name	Building Use	Building SubUse	Building Structure
A (BUILDING)	Residential	Bungalow/ Dwelling / Non Apartment	Non-Highrise

LTP NAME AND SIGNATURE	STRUCTURAL ENG'S NAME AND SIGNATURE	BUILDER NAME AND SIGNATURE	DIGITAL SIGNATURE
SHAIENDRA KUMAR VERMA MNNP/ENG/0007/2021			