

FAR & Tenement Details (Table 4c-1)

Building	No. of Same Bldg	Total Built Up Area (Sq.mt.)	Proposed FAR Area (Sq.mt.) Resi.	Total FAR Area (Sq.mt.)	Total Consumed Additional FAR Area (Sq.mt.)	Tnmt (No.)
A (RESIDENTIAL)	1	148.12	148.12	148.12	148.12	01
Grand Total :	1	148.12	148.12	148.12	148.12	01

Proposal Basic Information

Proposal File No.	MNNP/BP/0039/W03/2024
Owner Name	PAMMI RANI
Khata No	24
Plot No	31
Village Name	Nimiya
Use	Residential
SubUse	Bungalow/ Dwelling / Non Apartment

AREA STATEMENT	VERSION NO. : 1.0.68
MEDINAGAR MUNICIPAL CORPORATION	VERSION DATE: 16/10/2020
PROJECT DETAIL:	
Region : JHARKHAND URBAN LOCAL BODIES	Plot Use: Residential
District: PALANJU	Plot SubUse: Bungalow/ Dwelling / Non Apartment
Authority: MEDINAGAR MUNICIPAL CORPORATION	PlotNearbyReligiousStructure: NA
Inward No: MNNP/BP/0039/W03/2024	Plot/SubPlot No: 31
Application Type: General Proposal	North: -
Project Type: Building Permission	South: -
Nature of Development: New	East: -
Location of Development Area: Old Area	West: -
AREA DETAILS:	
AREA OF PLOT (Minimum)	(A) 129.53 SQ.MT.
Deduction for NetPlot Area	2.72
Surrender Free of Cost	2.72
Total	126.81
NET AREA OF PLOT(Gross Plot Area - Deduction from Gross Plot area)	(A-Deductions) 126.81
Deduction for Balance Plot Area(from Gross Plot Area)	
Surrender Free of Cost	2.72
Common Plot	13.60
Total	113.22
BALANCE AREA OF PLOT(Net Plot Area - Recreational/Amenity space)	(A-Deductions) 113.22
PLOT AREA FOR COVERAGE(Net Plot Area)	(A-Deductions) 126.81
Plot Area for FAR (Net Plot Area + RoadWidening Area)	(A-Deductions) 129.53
COVERAGE CHECK	
Permissible Coverage area (70.00 %)	88.77
Proposed Coverage Area (58.40 %)	74.06
Total Prop. Coverage Area (58.4 %)	74.06
Balance coverage area (11.60 %)	14.71
FAR CHECK	
Perm. FAR Area (1.200)	155.44
Total Perm. FAR area	155.44
Residential FAR	148.11
Proposed FAR Area	148.11
Total Proposed FAR Area	148.11
Consumed FAR (Factor)	1.14
Balance FAR Area	7.33
BUILT UP AREA CHECK	
Total Proposed BuiltUp Area	148.12
ARCHITECT (Regd)	AYUSH RANJAN
ENGINEER (Regd)	
SUPERVISOR (Regd)	
OWNER (Regd)	PAMMI RANI
DEVELOPMENT AUTHORITY LOCAL BODY	

COLOR INDEX	
PLOT BOUNDARY	Black
ABUTTING ROAD	Green
PROPOSED CONSTRUCTION	Red
COMMON PLOT	Yellow
ROAD WIDENING AREA	Blue
EXISTING (To be retained)	Light Blue
EXISTING (To be demolished)	Light Yellow

Buildingwise Floor FAR Details

Floor Name	Building Name A (RESIDENTIAL)		Total	
	Proposed Built Up Area (Sq.mt.)	Proposed FAR Area (Sq.mt.)	Total Proposed Built Up Area (Sq.mt.)	Total FAR Area (Sq.mt.)
Ground Floor	74.06	74.06	74.06	74.06
First Floor	74.06	74.06	74.06	74.06
Terrace Floor	0.00	0.00	0.00	0.00
Total :	148.12	148.12	148.12	148.12

Building USE/SUBUSE Details

Building Name	Building Use	Building SubUse	Building Structure
A (RESIDENTIAL)	Residential	Bungalow/ Dwelling / Non Apartment	Non-Highrise

LTP NAME AND SIGNATURE	STRUCTURAL ENG'S NAME AND SIGNATURE	BUILDER NAME AND SIGNATURE	DIGITAL SIGNATURE
AYUSH RANJAN MNNP/ENG/004/2023			

Proposal Basic Information	
Proposal File No.	MNNP/BP/0039/W03/2024
Owner Name	PAMMI RANI
Khata No	24
Plot No	31
Village Name	Nimiya
Use	Residential
SubUse	Bungalow/ Dwelling / Non Apartment

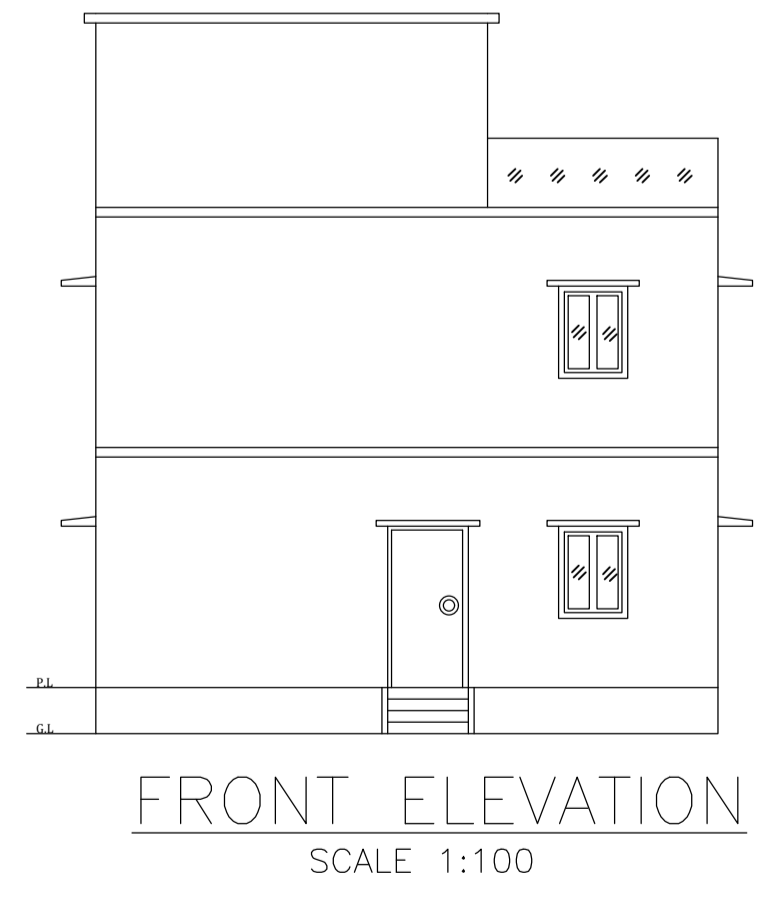
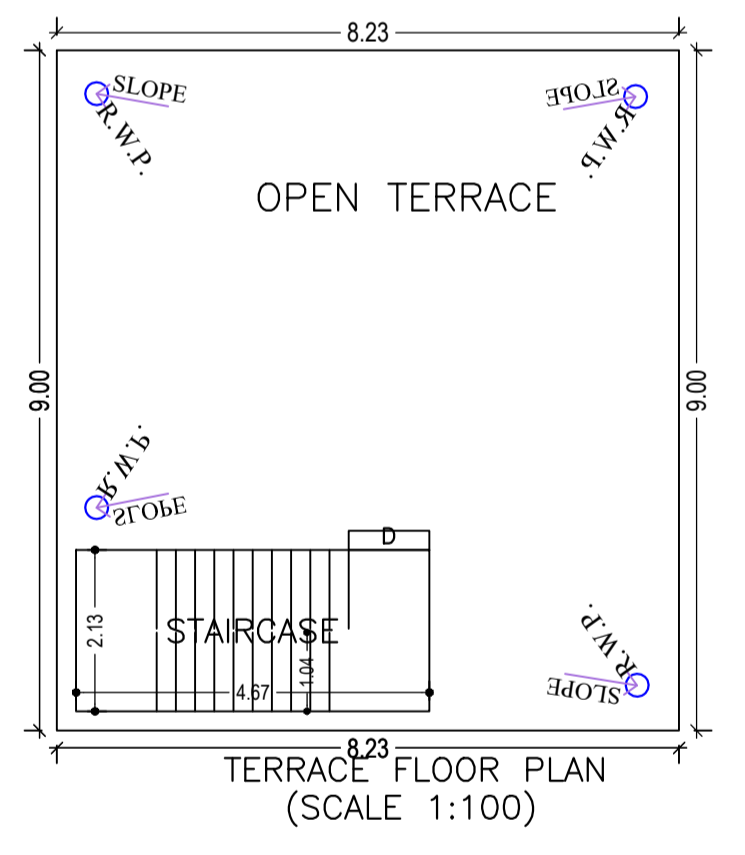
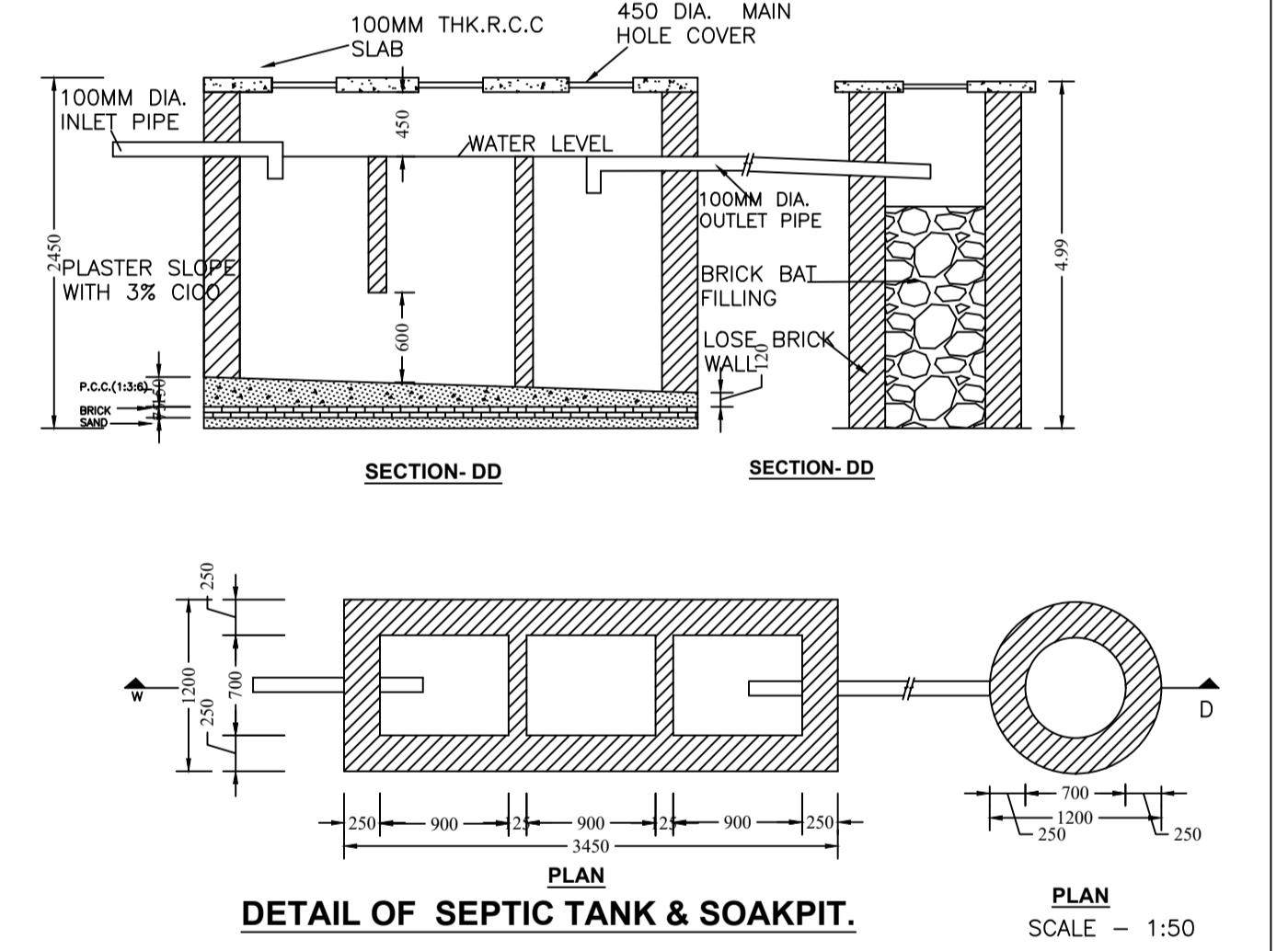
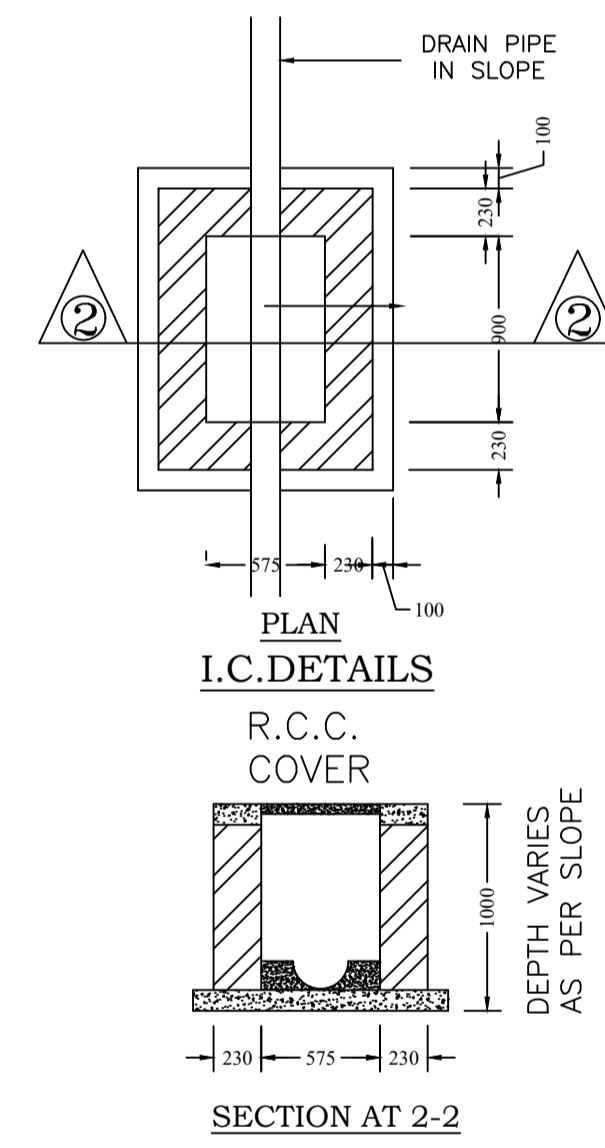
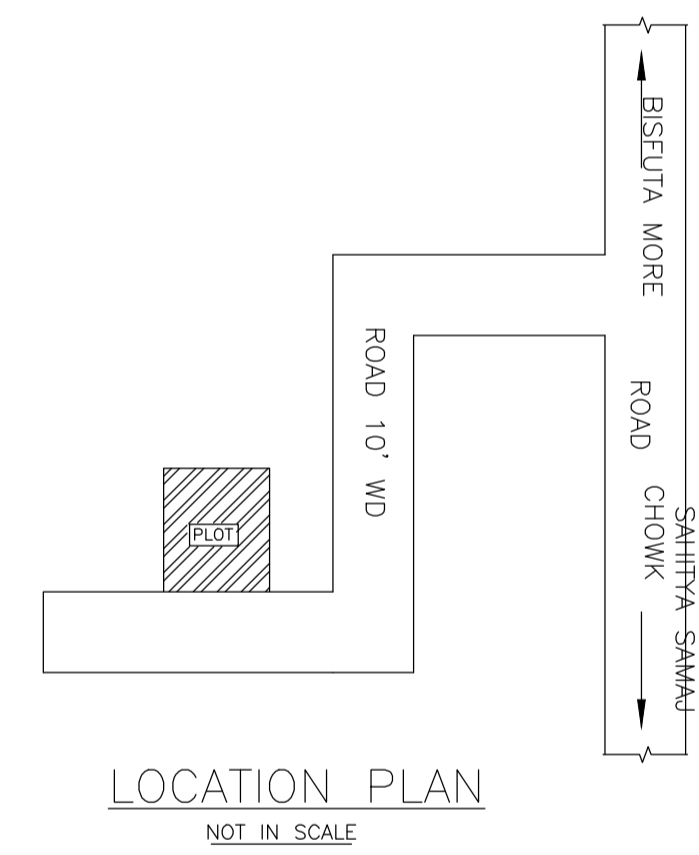
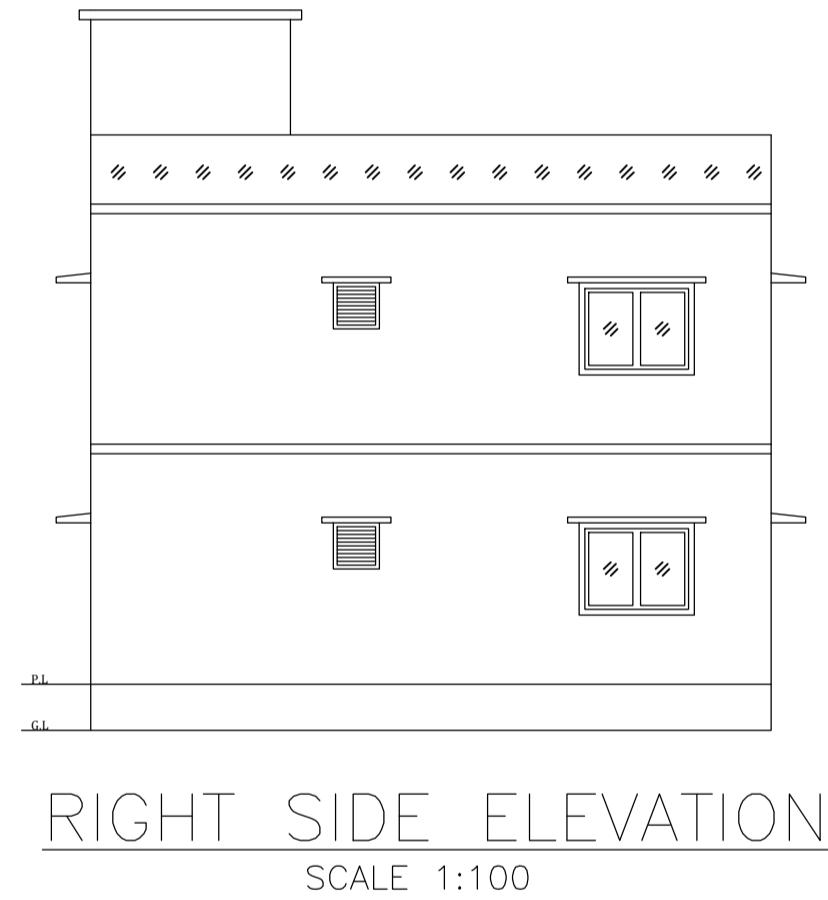
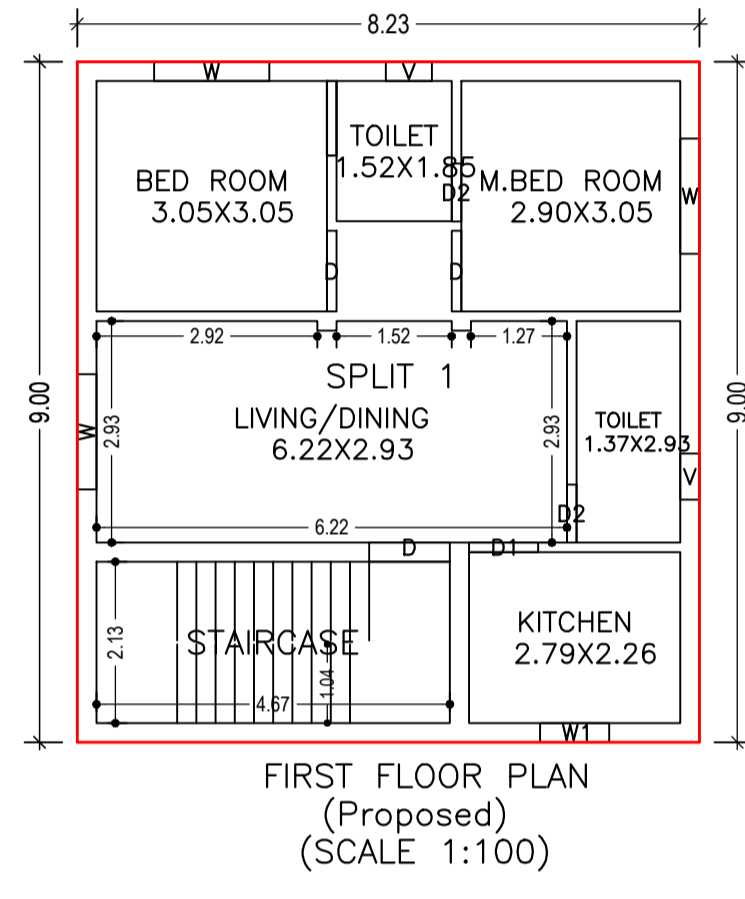
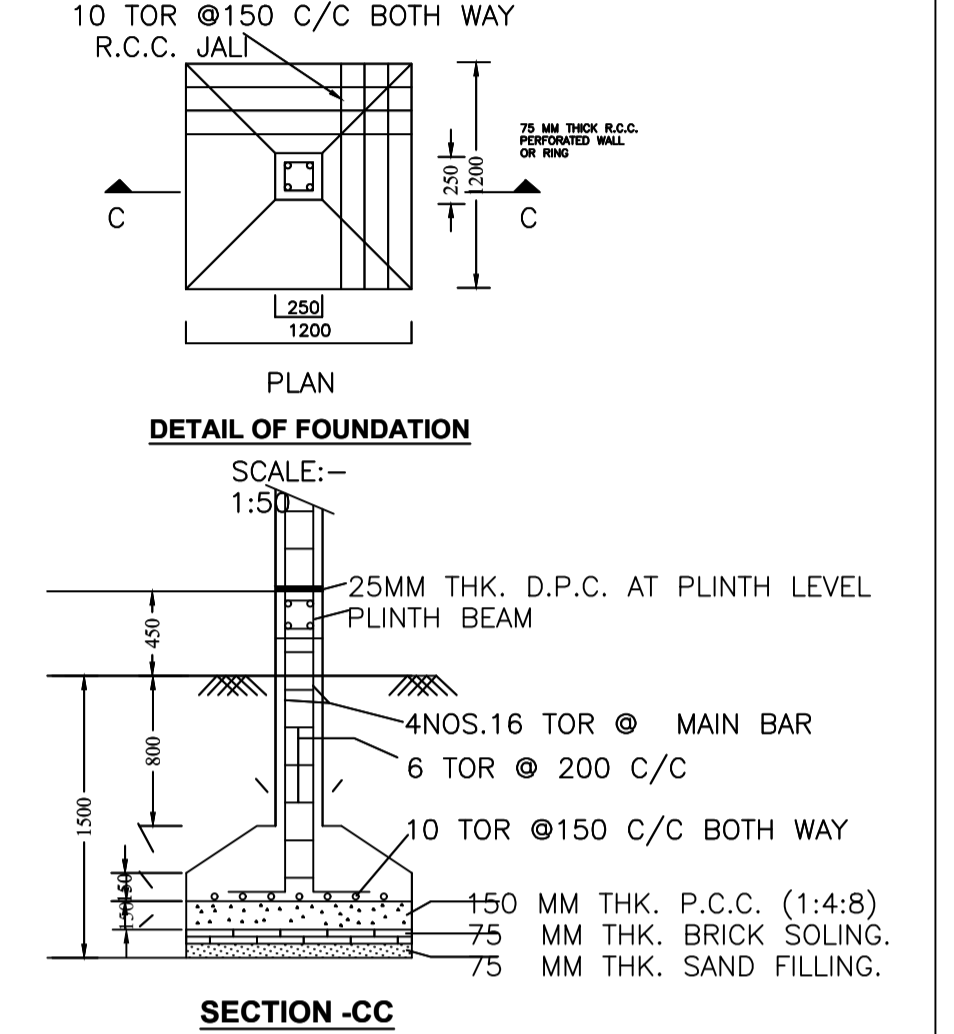
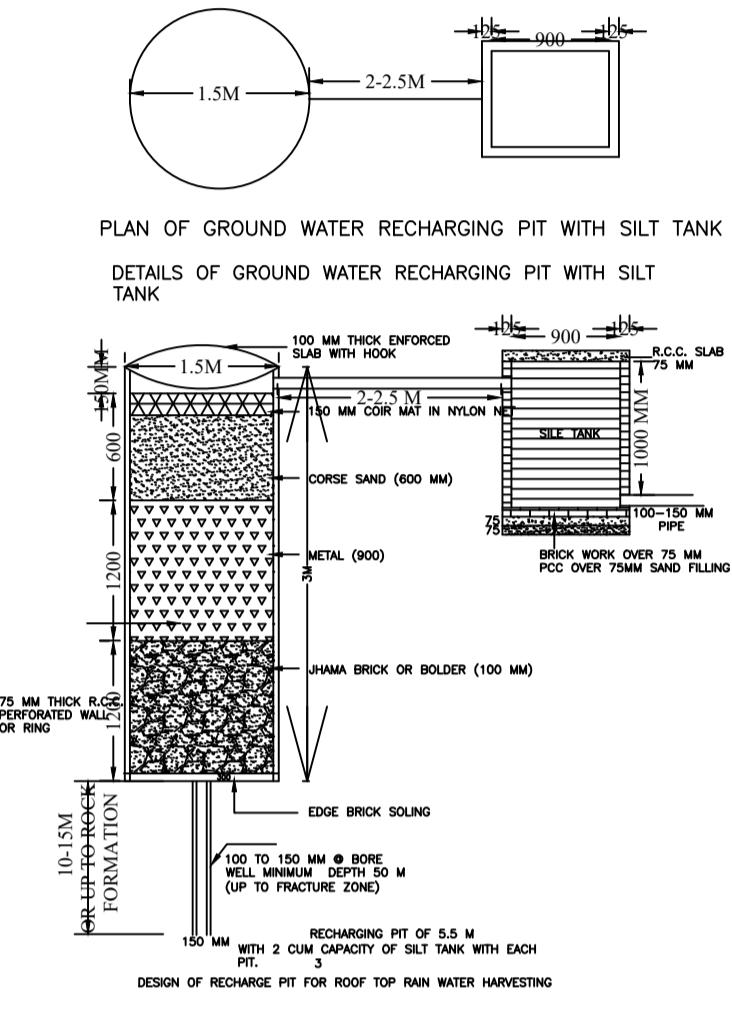
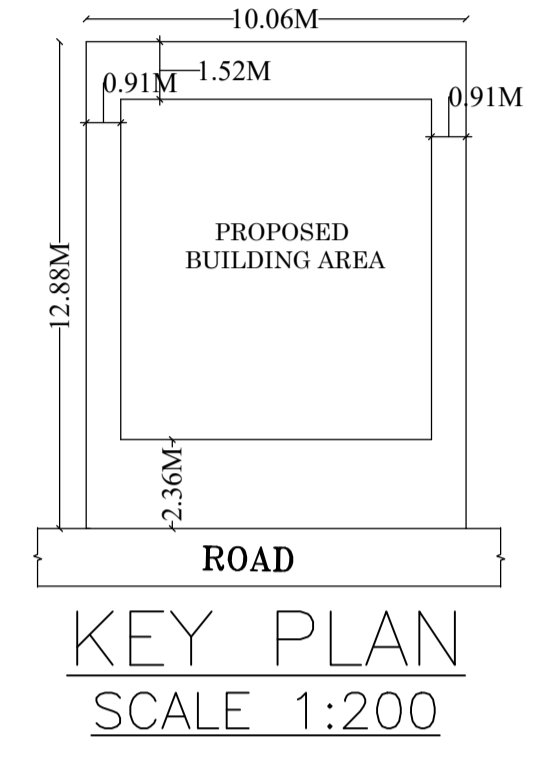
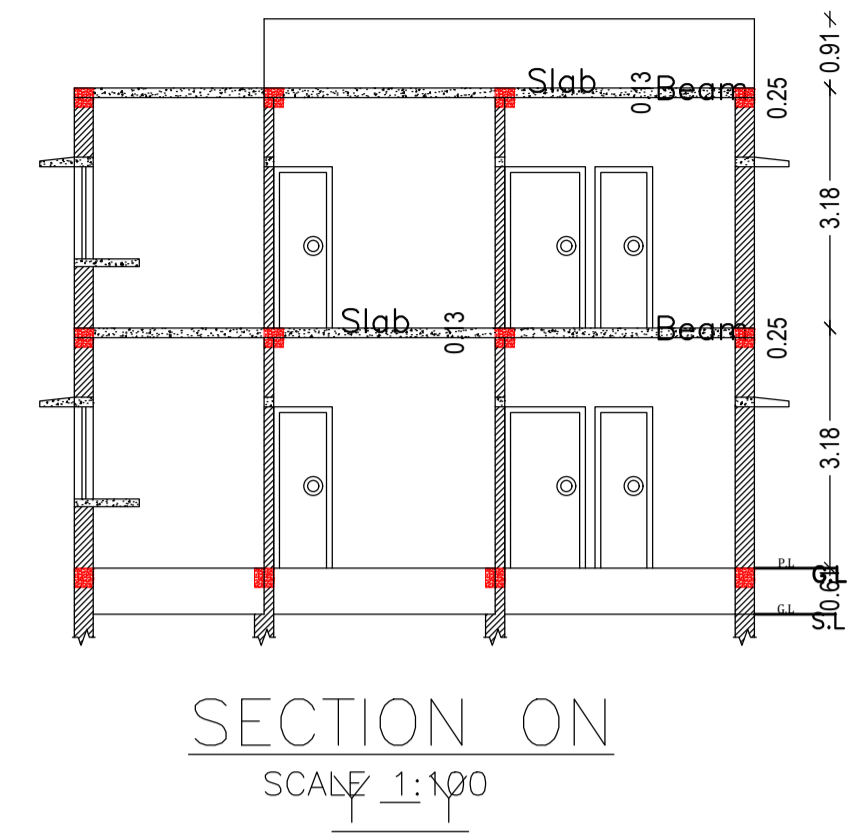
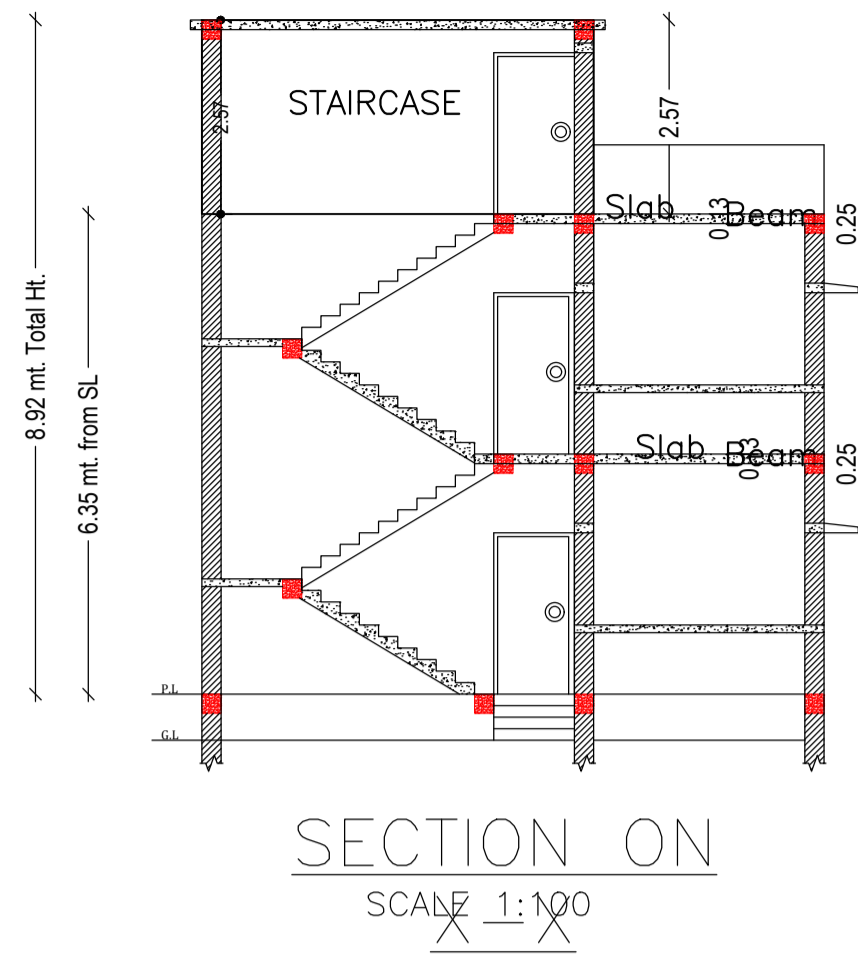
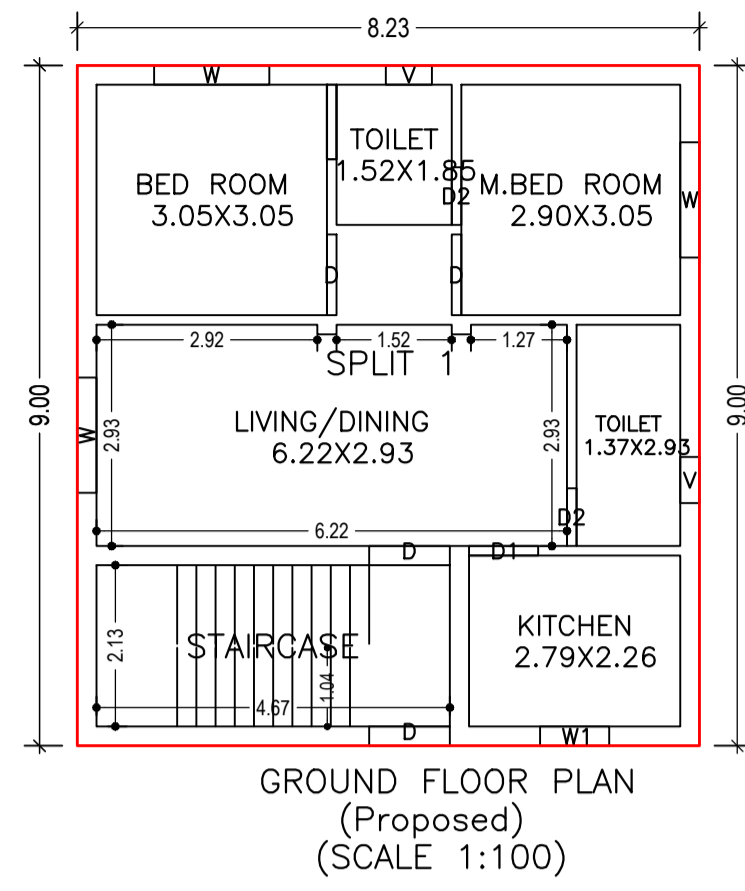

Building :A (RESIDENTIAL)

Floor Name	Total Built Up Area (Sq.mt.)	Proposed FAR Area (Sq.mt.) Resi.	Total FAR Area (Sq.mt.)	Total Consumed Additional FAR Area (Sq.mt.)	Tnmt (No.)
Ground Floor	74.06	74.06	74.06	74.06	01
First Floor	74.06	74.06	74.06	74.06	00
Terrace Floor	0.00	0.00	0.00	0.00	00
Total:	148.12	148.12	148.12	148.12	01
Total Number of Same Buildings	1				
Total:	148.12	148.12	148.12	148.12	01

SCHEDULE OF DOOR:

BUILDING NAME	NAME	LENGTH	HEIGHT	NOS
A (RESIDENTIAL)	D2	0.76	2.10	04
A (RESIDENTIAL)	D1	0.91	2.10	02
A (RESIDENTIAL)	D	1.07	2.10	06

SCHEDULE OF WINDOW/VENTILATION:

BUILDING NAME	NAME	LENGTH	HEIGHT	NOS
A (RESIDENTIAL)	V	0.61	0.61	04
A (RESIDENTIAL)	W1	0.91	1.22	02
A (RESIDENTIAL)	W	1.52	1.52	06

UnitBUA Table for Building :A (RESIDENTIAL)

FLOOR	Name	UnitBUA Type	UnitBUA Area	Carpet Area	No. of Rooms	No. of Tenement
GROUND FLOOR PLAN	SPLIT 1	FLAT	107.59	107.34	6	1
FIRST FLOOR PLAN	SPLIT 1	FLAT	0.00	0.00	6	0
Total:	-	-	107.59	107.34	12	1

LTP NAME AND SIGNATURE	STRUCTURAL ENG'S NAME AND SIGNATURE	BUILDER NAME AND SIGNATURE	DIGITAL SIGNATURE
AYUSH RANJAN MNNP/ENG/0004/2023			