

SITE PLAN

Proposal Basic Information	
Proposal File No.	MNNP/BP/0031/W17/2024
Owner Name	PIYUSHANKA MISHRA
Khata No	183
Plot No	1593
Village Name	Redma
Use	Residential
SubUse	Bungalow/ Dwelling / Non Apartment

AREA STATEMENT		VERSION NO.: 1.0.68
MEDINAGAR MUNICIPAL CORPORATION		VERSION DATE: 16/10/2020
PROJECT DETAIL:		
Region: JHARKHAND URBAN LOCAL BODIES	Plot Use: Residential	
District: PALAMU	Plot SubUse: Bungalow/ Dwelling / Non Apartment	
Authority: MEDINAGAR MUNICIPAL CORPORATION	PlotNearbyReligiousStructure: NA	
Inward_No: MNNP/BP/0031/W17/2024	Plot/SubPlot No: 1593	
Application Type: General Proposal	North: -	
Project Type: Building Permission	South: -	
Nature of Development: New	East: -	
Location of Development Area: New Area	West: -	
AREA DETAILS:		SQ.MT.
AREA OF PLOT (Minimum)	(A)	202.42
Deduction for NetPlot Area		
Surrender Free of Cost		15.48
Total		15.48
NET AREA OF PLOT(Gross Plot Area - Deduction from Gross Plot area)	(A-Deductions)	186.93
Deduction for Balance Plot Area(from Gross Plot Area)		
Surrender Free of Cost		15.48
Common Plot		38.42
Total		53.91
BALANCE AREA OF PLOT(Net Plot Area - Recreational/Amenity space)	(A-Deductions)	148.51
PLOT AREA FOR COVERAGE(Net Plot Area)	(A-Deductions)	186.93
Plot Area for FAR (Net Plot Area + Road/Widening Area)	(A-Deductions)	202.42
COVERAGE CHECK		
Permissible Coverage area (70.00 %)		130.85
Proposed Coverage Area (48.84 %)		91.30
Total Prop. Coverage Area (48.84 %)		91.30
Balance coverage area (21.16 %)		39.55
FAR CHECK		
Perm. FAR Area (1.500)		303.63
Total Perm. FAR area		303.63
Residential FAR		273.89
Proposed FAR Area		273.89
Total Proposed FAR Area		273.89
Consumed FAR (Factor)		1.35
Balance FAR Area		29.74
BUILT UP AREA CHECK		
Total Proposed BuiltUp Area		273.90
ARCHITECT (Regd)	RANJIT KUMAR	
ENGINEER (Regd)		
SUPERVISOR (Regd)		
OWNER (Regd)	PIYUSHANKA MISHRA	
DEVELOPMENT AUTHORITY		LOCAL BODY

COLOR INDEX	
PLOT BOUNDARY	Black
ABUTTING ROAD	Green
PROPOSED CONSTRUCTION	Red
COMMON PLOT	Yellow
ROAD WIDENING AREA	Blue
EXISTING (To be retained)	Blue
EXISTING (To be demolished)	Yellow

Buildingwise Floor FAR Details

Floor Name	Building Name A (RESIDENTIAL)		Total	
	Proposed Built Up Area (Sq.mt.)	Proposed FAR Area (Sq.mt.)	Total Proposed Built Up Area (Sq.mt.)	Total FAR Area (Sq.mt.)
Ground Floor	91.30	91.30	91.30	91.30
First Floor	91.30	91.30	91.30	91.30
Second Floor	91.30	91.30	91.30	91.30
Terrace Floor	0.00	0.00	0.00	0.00
Total :	273.90	273.90	273.90	273.90

Building USE/SUBUSE Details

Building Name	Building Use	Building SubUse	Building Structure
A (RESIDENTIAL)	Residential	Bungalow/ Dwelling / Non Apartment	Non-Highrise

FAR & Tenement Details (Table 4c-1)

Building	No. of Same Bldg	Total Built Up Area (Sq.mt.)	Proposed FAR Area (Sq.mt.) Resi.	Total FAR Area (Sq.mt.)	Total Consumed Additional FAR Area (Sq.mt.)	Trmt (No.)
A (RESIDENTIAL)	1	273.90	273.90	273.90	273.90	01
Grand Total :	1	273.90	273.90	273.90	273.90	01

LTP NAME AND SIGNATURE	STRUCTURAL ENG'S NAME AND SIGNATURE	BUILDER NAME AND SIGNATURE	DIGITAL SIGNATURE
RANJIT KUMAR MNNP/ENG/0001/2016			

Proposal Basic Information	
Proposal File No.	MNNP/BP/0031/W17/2024
Owner Name	PIYUSHANKA MISHRA
Khata No	183
Plot No	1593
Village Name	Redma
Use	Residential
SubUse	Bungalow Dwelling / Non Apartment

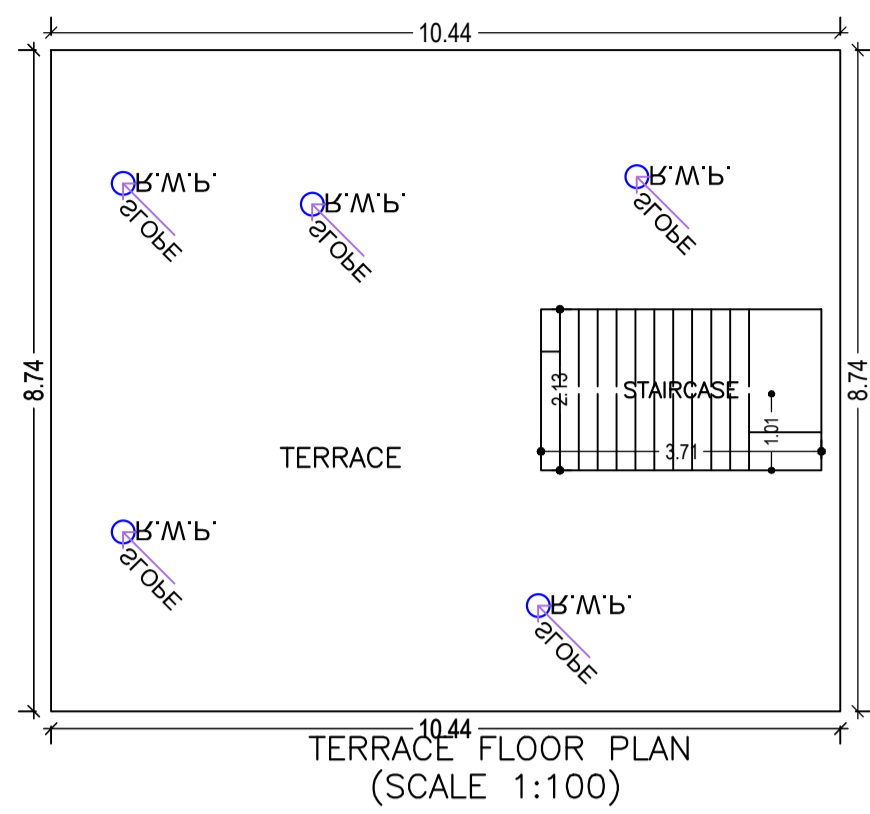

Building :A (RESIDENTIAL)

Floor Name	Total Built Up Area (Sq.mt.)	Proposed FAR Area (Sq.mt.) Res.	Total FAR Area (Sq.mt.)	Total Consumed Additional FAR Area (Sq.mt.)	Tnmt (No.)
Ground Floor	91.30	91.30	91.30	91.30	01
First Floor	91.30	91.30	91.30	91.30	00
Second Floor	91.30	91.30	91.30	91.30	00
Terrace Floor	0.00	0.00	0.00	0.00	00
Total :	273.90	273.90	273.90	273.90	01
Total Number of Same Buildings :	1				
Total :	273.90	273.90	273.90	273.90	01

SCHEDULE OF DOOR:

BUILDING NAME	NAME	LENGTH	HEIGHT	NOS
A (RESIDENTIAL)	D	0.79	2.10	15
A (RESIDENTIAL)	D	0.90	2.10	15

SCHEDULE OF WINDOW/VENTILATION:

BUILDING NAME	NAME	LENGTH	HEIGHT	NOS
A (RESIDENTIAL)	W	1.20	1.20	30
A (RESIDENTIAL)	V	1.20	1.20	03

UnitBUA Table for Building :A (RESIDENTIAL)

FLOOR	Name	UnitBUA Type	UnitBUA Area	Carpet Area	No. of Rooms	No. of Tenement
GROUND FLOOR PLAN	SPLIT A	FLAT	248.59	247.71	8	1
FIRST FLOOR PLAN	SPLIT A	FLAT	0.00	0.00	8	0
SECOND FLOOR PLAN	SPLIT A	FLAT	0.00	0.00	8	0
Total:	-	-	248.59	247.71	24	1

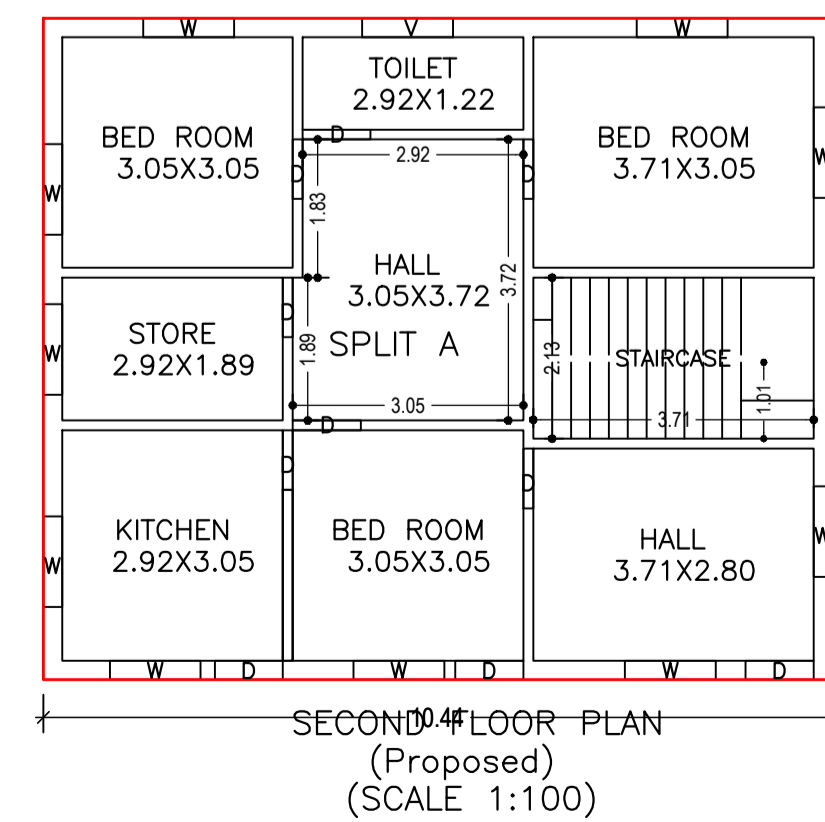
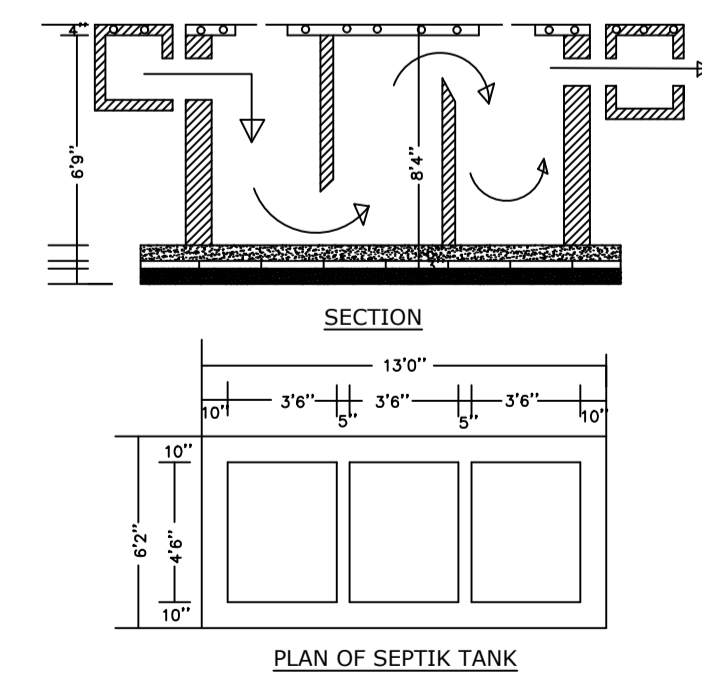
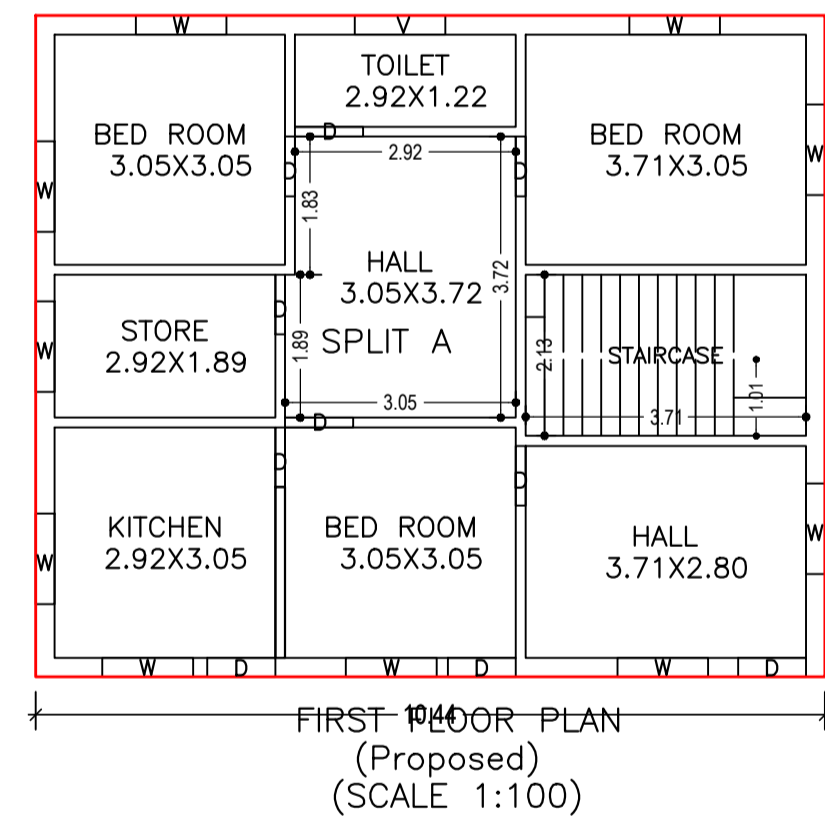
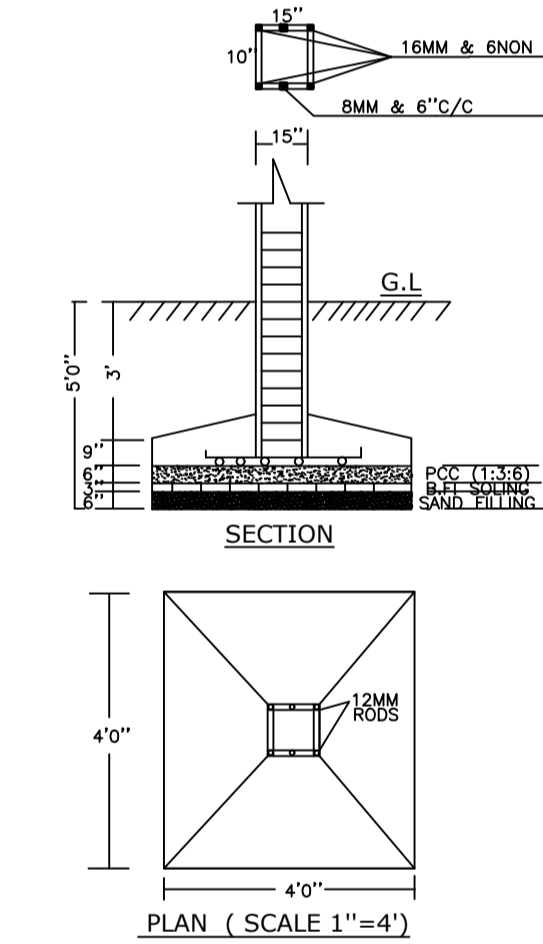
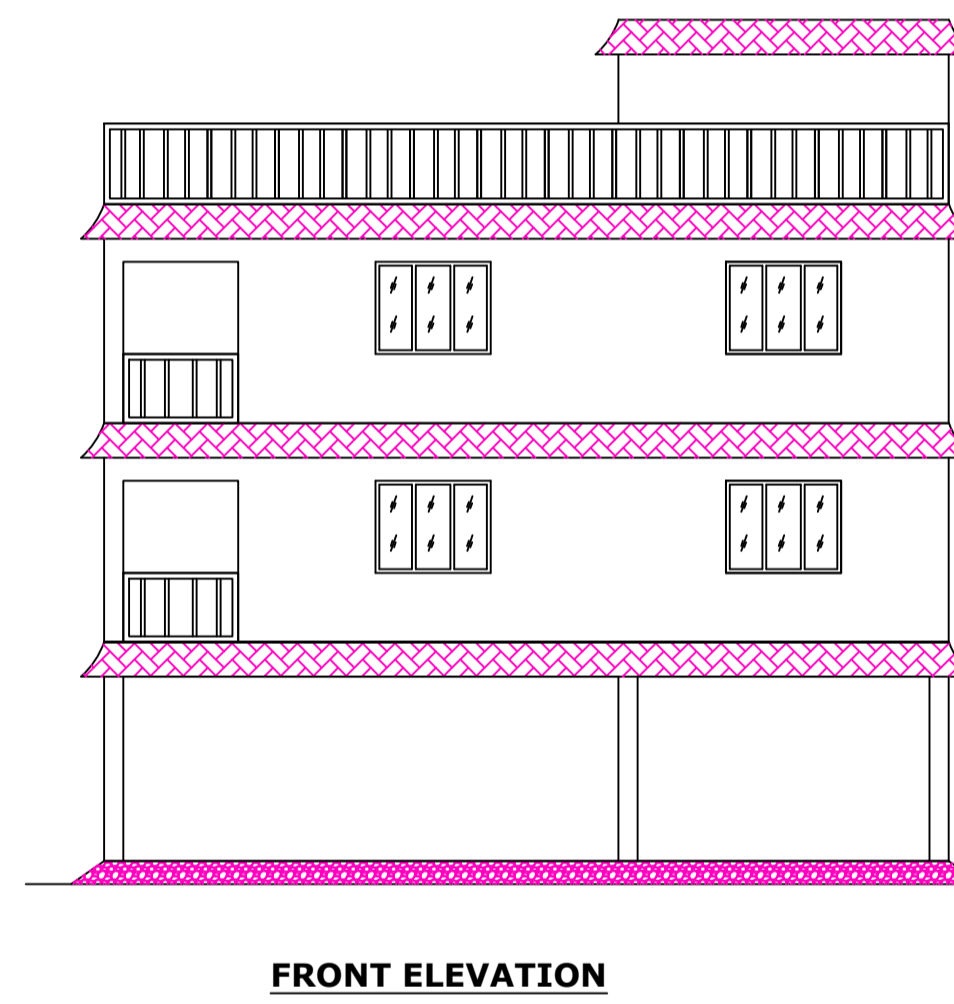
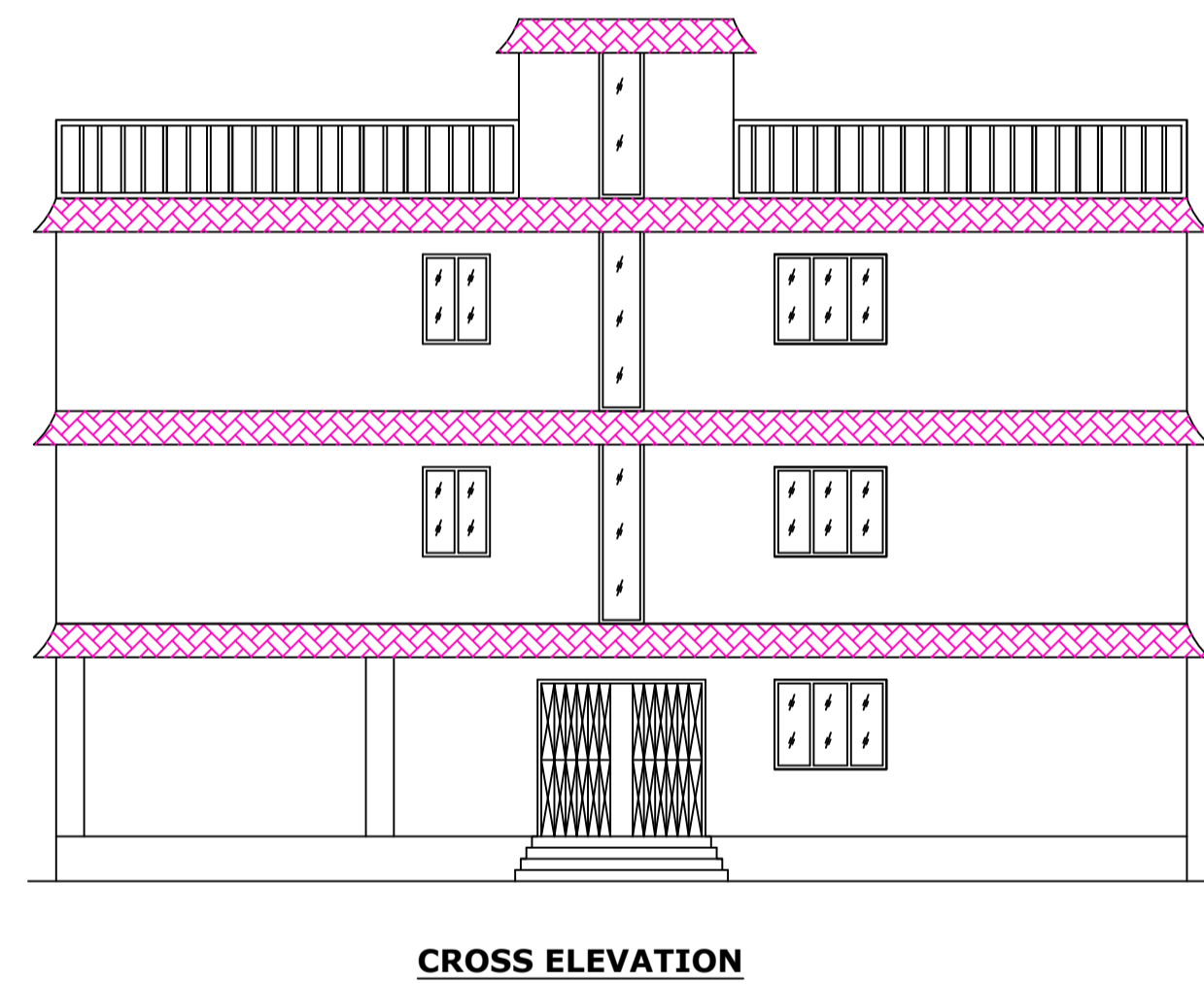
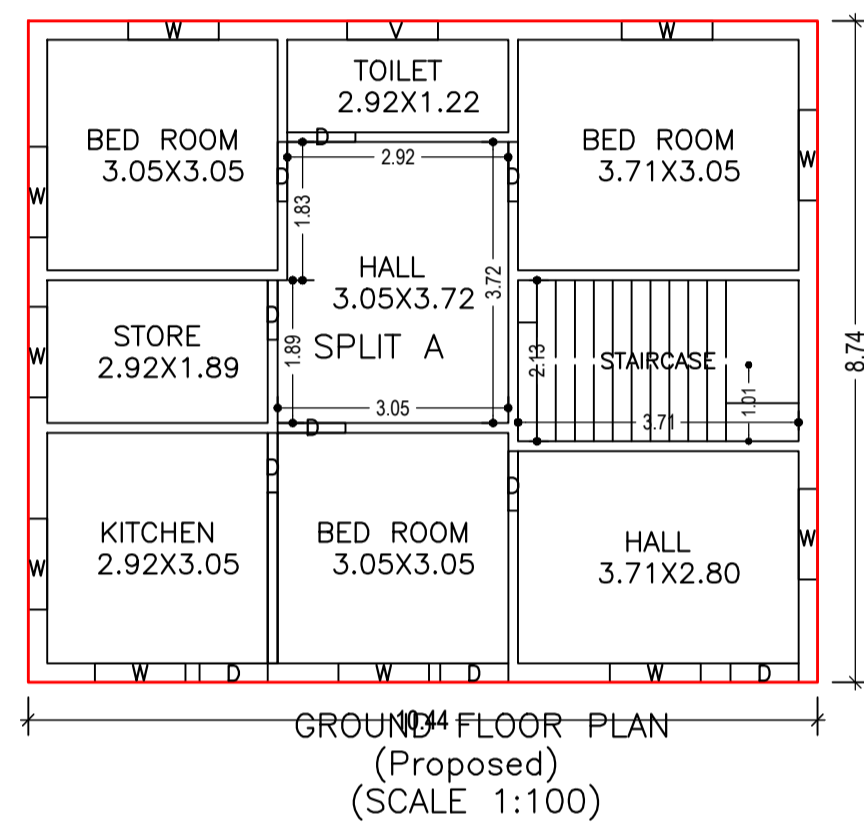
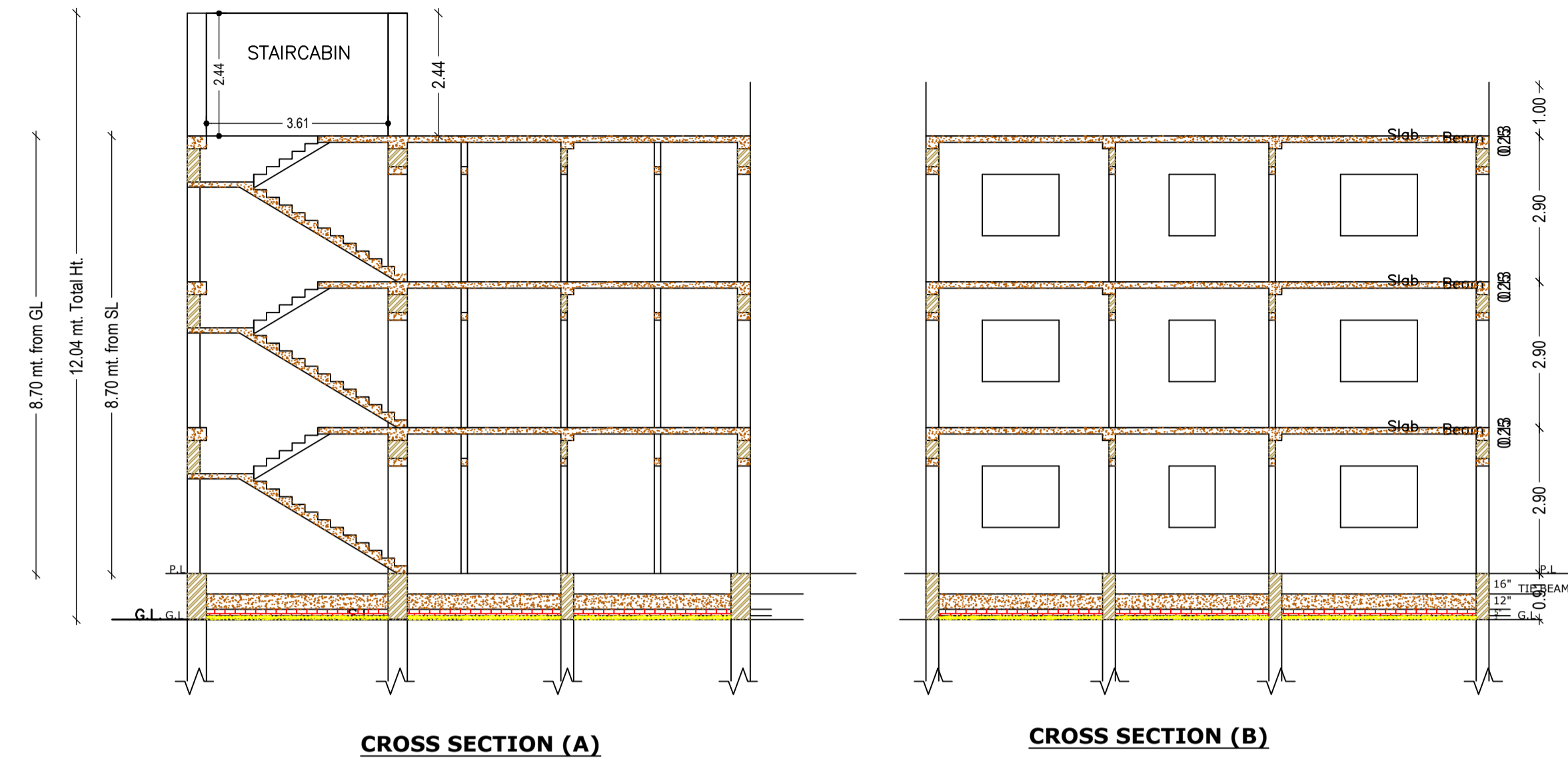

LTP NAME AND SIGNATURE	STRUCTURAL ENG'S NAME AND SIGNATURE	BUILDER NAME AND SIGNATURE	DIGITAL SIGNATURE
RANJIT KUMAR MNNP/ENG/0001/2016			