

Proposal Basic Information

Proposal File No.	MNNP/BP/0038/W10/2024
Owner Name	Nitu singh
Khata No	145
Plot No	1648
Village Name	Sudna
Use	Residential
SubUse	Bungalow Dwelling / Non Apartment

FAR & Tenement Details (Table 4c-1)

Building	No. of Same Bldg	Total Built Up Area (Sq.mt.)	Proposed FAR Area (Sq.mt.) Resi.	Total FAR Area (Sq.mt.)	Total Consumed Additional FAR Area (Sq.mt.)	Tnmt (No.)
A (BUILDING)	1	88.64	88.64	88.64	88.64	01
Grand Total :	1	88.64	88.64	88.64	88.64	01

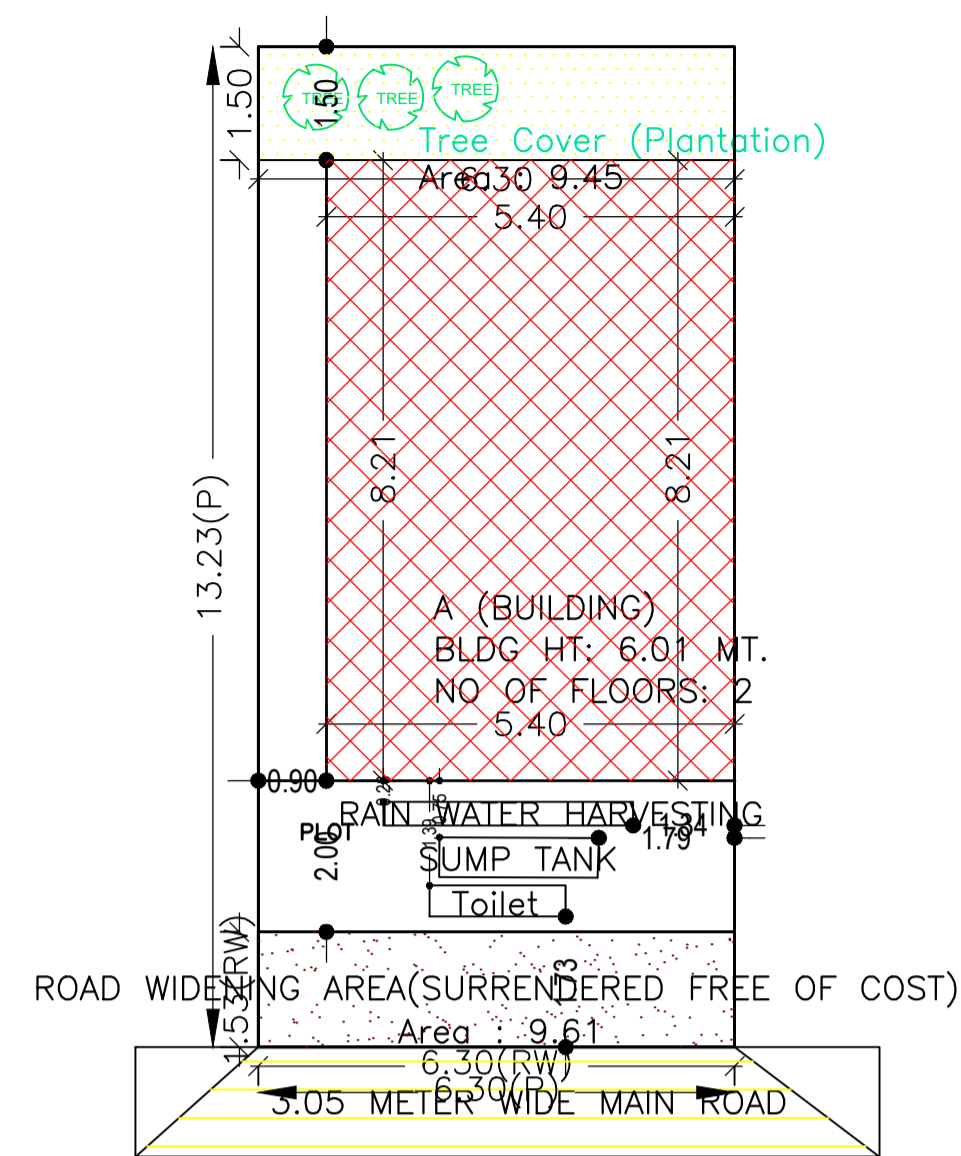

SITE PLAN

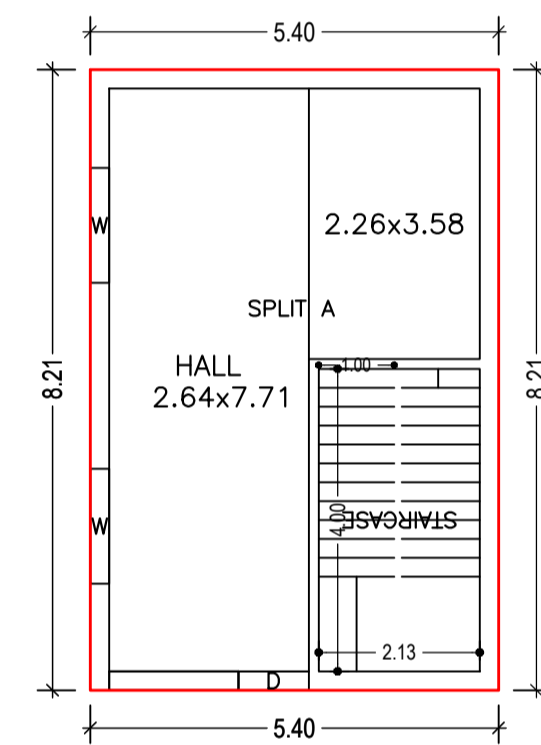

GROUND FLOOR PLAN (Proposed) (SCALE 1:100)

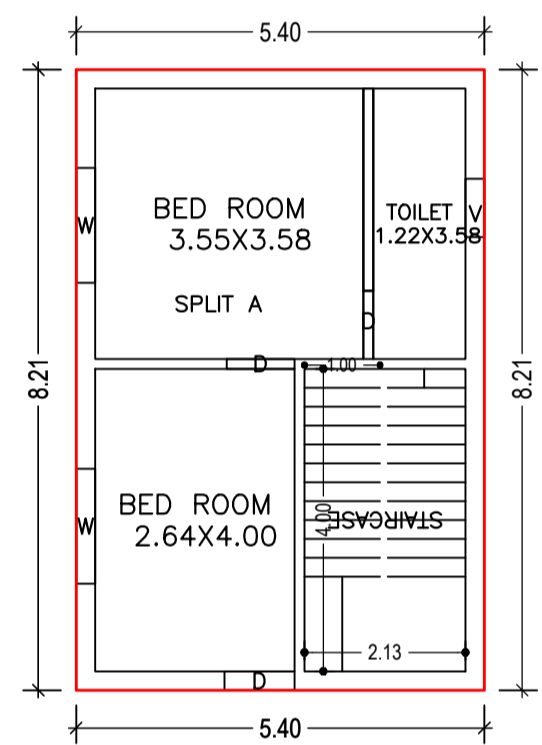

FIRST FLOOR PLAN (Proposed) (SCALE 1:100)

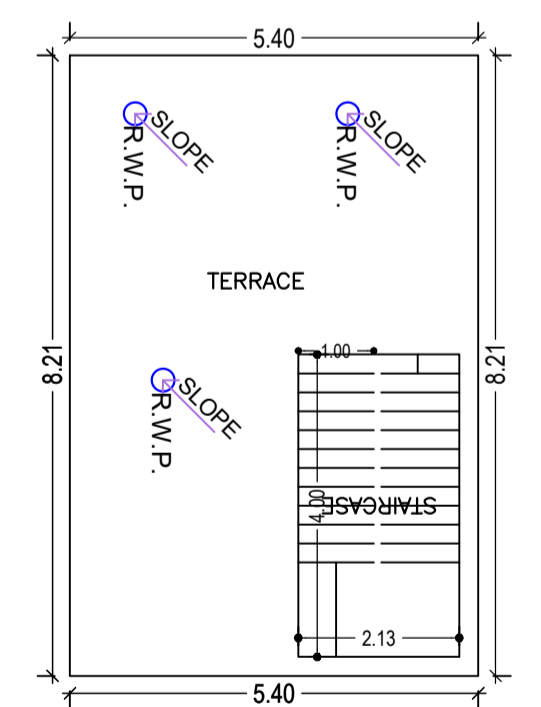

TERRACE FLOOR PLAN (SCALE 1:100)

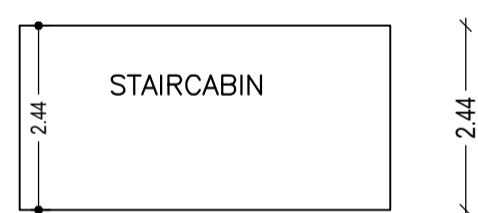

GL - S.L

Building :A (BUILDING)

Floor Name	Total Built Up Area (Sq.mt.)	Proposed FAR Area (Sq.mt.) Resi.	Total FAR Area (Sq.mt.)	Total Consumed Additional FAR Area (Sq.mt.)	Tnmt (No.)
Ground Floor	44.32	44.32	44.32	44.32	01
First Floor	44.32	44.32	44.32	44.32	00
Terrace Floor	0.00	0.00	0.00	0.00	00
Total :	88.64	88.64	88.64	88.64	01
Total Number of Same Buildings :	1				
Total :	88.64	88.64	88.64	88.64	01

SCHEDULE OF DOOR:

BUILDING NAME	NAME	LENGTH	HEIGHT	NOS
A (BUILDING)	D	0.90	2.10	02
A (BUILDING)	D	0.93	2.10	02

SCHEDULE OF WINDOW/VENTILATION:

BUILDING NAME	NAME	LENGTH	HEIGHT	NOS
A (BUILDING)	V	0.77	0.60	01
A (BUILDING)	W	1.52	1.20	04

UnitBUA Table for Building :A (BUILDING)

FLOOR	Name	UnitBUA Type	UnitBUA Area	Carpet Area	No. of Rooms	No. of Tenement
GROUND FLOOR PLAN	SPLIT A	FLAT	68.41	67.63	1	1
FIRST FLOOR PLAN	SPLIT A	FLAT	0.00	0.00	3	0
Total:	-	-	68.41	67.63	4	1

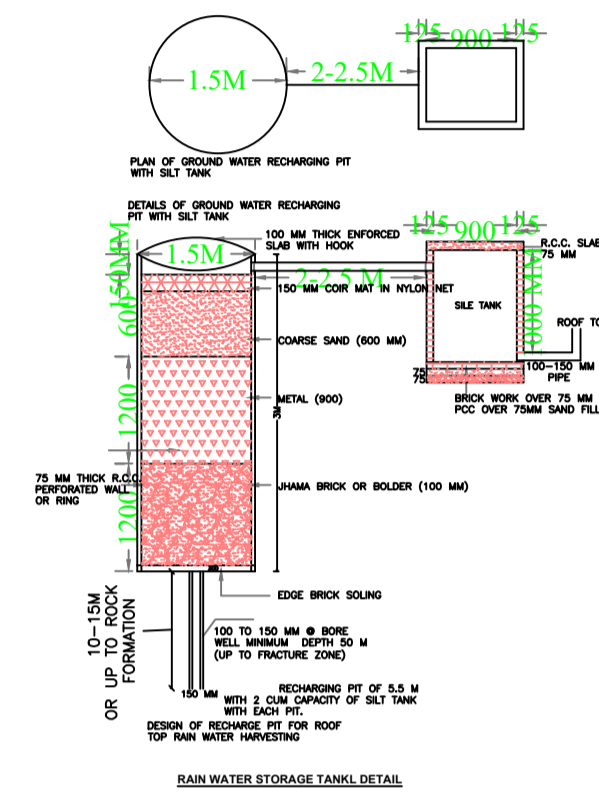

RAIN WATER STORAGE TANK DETAIL

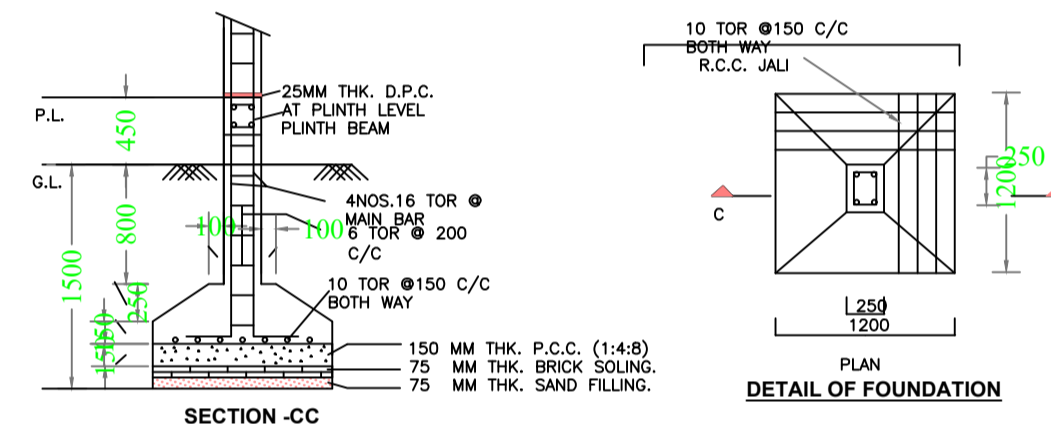

STRUCTURAL DETAIL

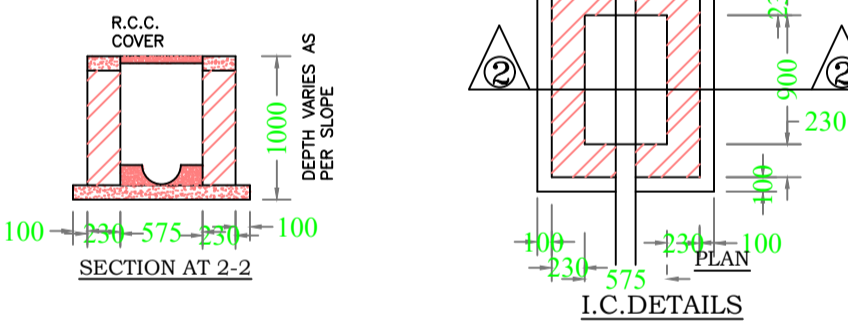

SECTION AT 2-2

L.C. DETAILS

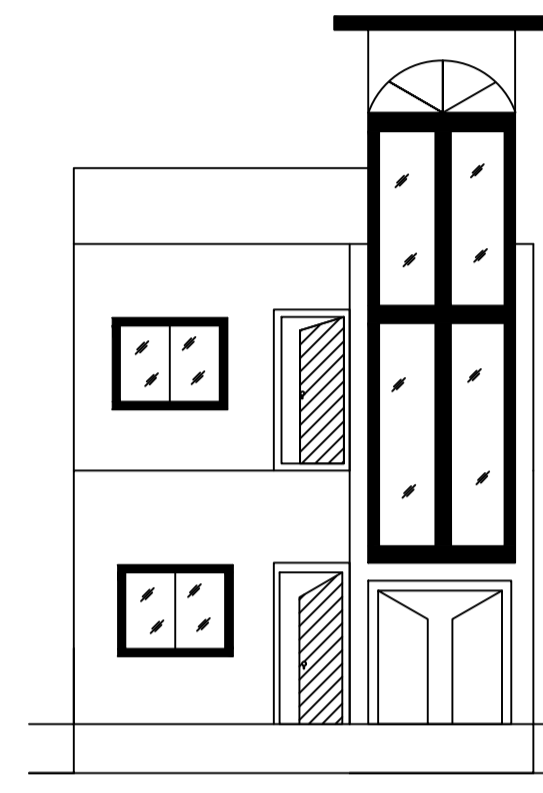

FRONT ELEVATION

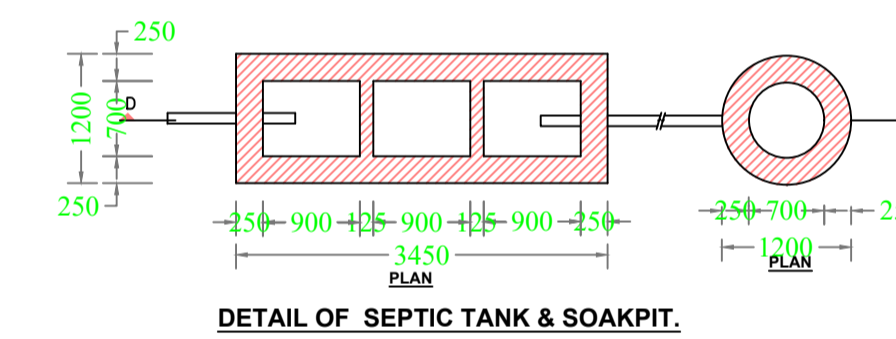

DETAIL OF SEPTIC TANK & SOAKPIT.

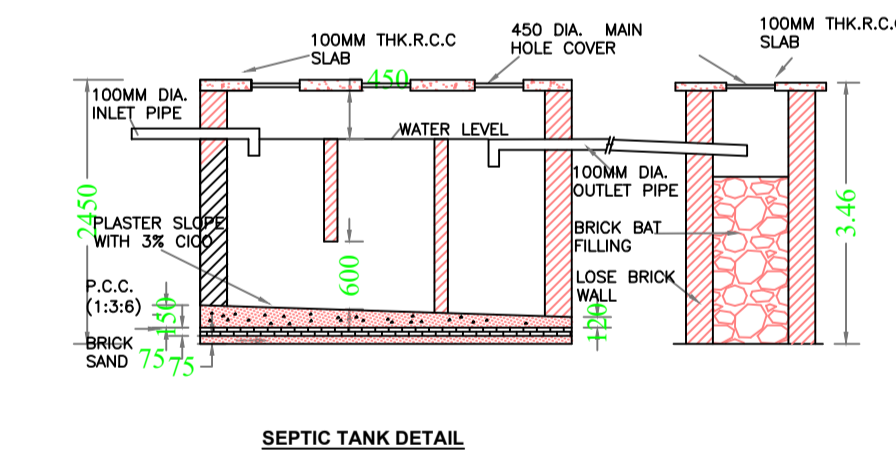

SEPTIC TANK DETAIL

AREA STATEMENT	VERSION NO. : 1.0.68
MEDINAGAR MUNICIPAL CORPORATION	VERSION DATE: 16/10/2020
PROJECT DETAIL:	
Region : JHARKHAND URBAN LOCAL BODIES	Plot Use: Residential
District: PALAMU	Plot SubUse: Bungalow Dwelling / Non Apartment
Authority: MEDINAGAR MUNICIPAL CORPORATION	Plot/Nearby/Religious Structure: NA
Inward No: MNNP/BP/0038/W10/2024	Plot/SubPlot No: 1648
Application Type: General Proposal	North: -
Project Type: Building Permission	South: -
Nature of Development: New	East: -
Location of Development Area: Old Area	West: -
AREA DETAILS:	SQ.MT.
AREA OF PLOT (Minimum)	(A) 83.38
Deduction for NetPlot Area	
Surrender Free of Cost	9.61
Total	9.61
NET AREA OF PLOT(Gross Plot Area - Deduction from Gross Plot area)	(A-Deductions) 73.76
Deduction for Balance Plot Area(from Gross Plot Area)	
Surrender Free of Cost	9.61
Common Plot	9.45
Total	19.06
BALANCE AREA OF PLOT(Net Plot Area - Recreational/Amenity space)	(A-Deductions) 64.31
PLOT AREA FOR COVERAGE(Net Plot Area)	(A-Deductions) 73.76
Plot Area for FAR (Net Plot Area + Road/Widening Area)	(A-Deductions) 83.36
COVERAGE CHECK	
Permissible Coverage area (70.00 %)	51.63
Proposed Coverage Area (60.09 %)	44.32
Total Prop. Coverage Area (60.09 %)	44.32
Balance coverage area (9.91 %)	7.31
FAR CHECK	
Perm. FAR Area (1200)	100.03
Total Perm. FAR area	100.03
Residential FAR	88.64
Proposed FAR Area	88.64
Total Proposed FAR Area	88.64
Consumed FAR (Factor)	1.06
Balance FAR Area	11.39
BUILT UP AREA CHECK	
Total Proposed BuiltUp Area	88.64
ARCHITECT (Regd)	RANJIT KUMAR
ENGINEER (Regd)	
SUPERVISOR (Regd)	
OWNER (Regd)	Nitu singh
DEVELOPMENT AUTHORITY	LOCAL BODY

COLOR INDEX	
PLOT BOUNDARY	[Black Line]
ABUTTING ROAD	[Red Line]
PROPOSED CONSTRUCTION	[Green Line]
COMMON PLOT	[Yellow Line]
ROAD WIDENING AREA	[Blue Line]
EXISTING (To be retained)	[Orange Line]
EXISTING (To be demolished)	[Purple Line]

Buildingwise Floor FAR Details

Floor Name	Building Name A (BUILDING)		Total	
	Proposed Built Up Area (Sq.mt.)	Proposed FAR Area (Sq.mt.)	Total Proposed Built Up Area (Sq.mt.)	Total FAR Area (Sq.mt.)
Ground Floor	44.32	44.32	44.32	44.32
First Floor	44.32	44.32	44.32	44.32
Terrace Floor	0.00	0.00	0.00	0.00
Total :	88.64	88.64	88.64	88.64

Building USE/SUBUSE Details

Building Name	Building Use	Building SubUse	Building Structure
A (BUILDING)	Residential	Bungalow Dwelling / Non Apartment	Non-Highrise

LTP NAME AND SIGNATURE	STRUCTURAL ENG'S NAME AND SIGNATURE	BUILDER NAME AND SIGNATURE	DIGITAL SIGNATURE
RANJIT KUMAR MNNP/ENG/0001/2016			