

Proposal Basic Information

Proposal File No.	MNNP/BP/0033/W03/2024
Owner Name	SHWETA DEVI
Khata No	11
Plot No	145
Village Name	Sudma Bariya
Use	Residential
SubUse	Bungalow/ Dwelling / Non Apartment

FAR & Tenement Details (Table 4c-1)

Building	No. of Same Bldg	Total Built Up Area (Sq.mt.)	Proposed FAR Area (Sq.mt.) Resi.	Total FAR Area (Sq.mt.)	Total Consumed Additional FAR Area (Sq.mt.)	Tnmt (No.)
A1 (RESIDENTIAL)	1	70.67	70.67	70.67	70.67	01
Grand Total:	1	70.67	70.67	70.67	70.67	01

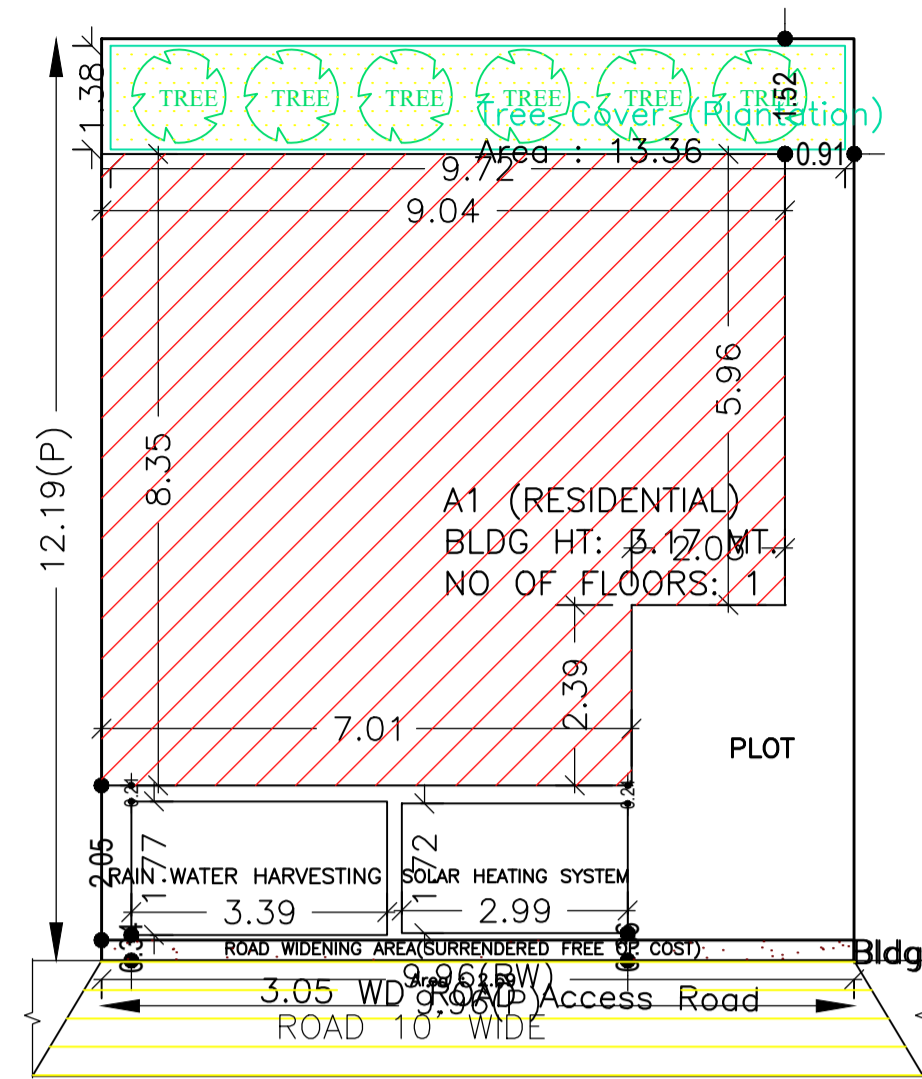

SITE PLAN

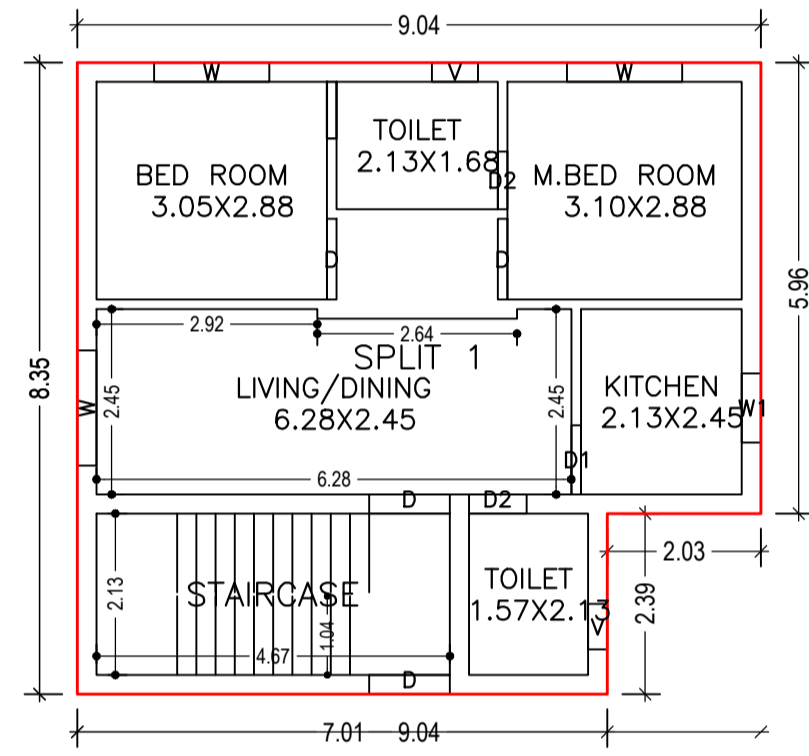

GROUND FLOOR PLAN (Proposed) (SCALE 1:100)

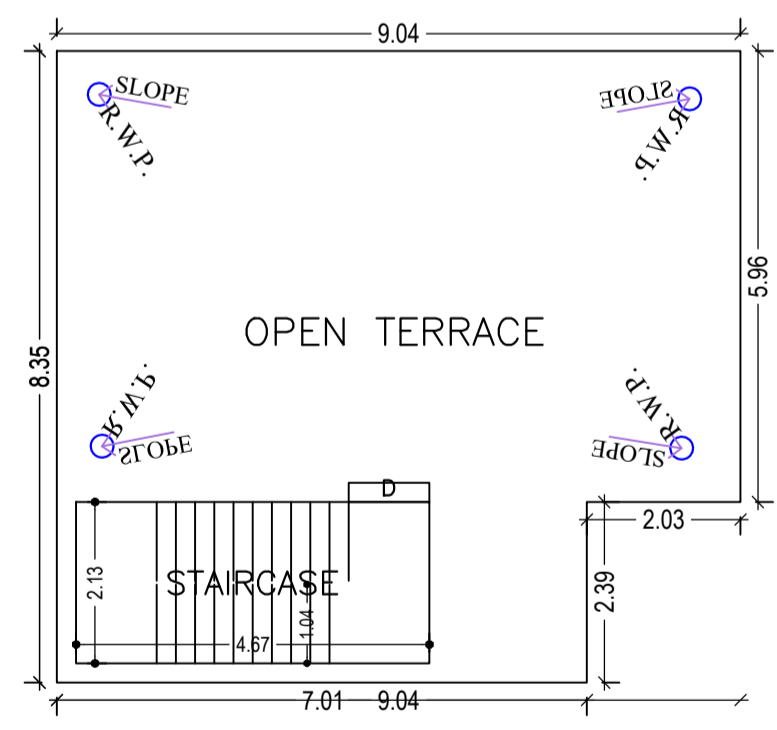

TERRACE FLOOR PLAN (SCALE 1:100)

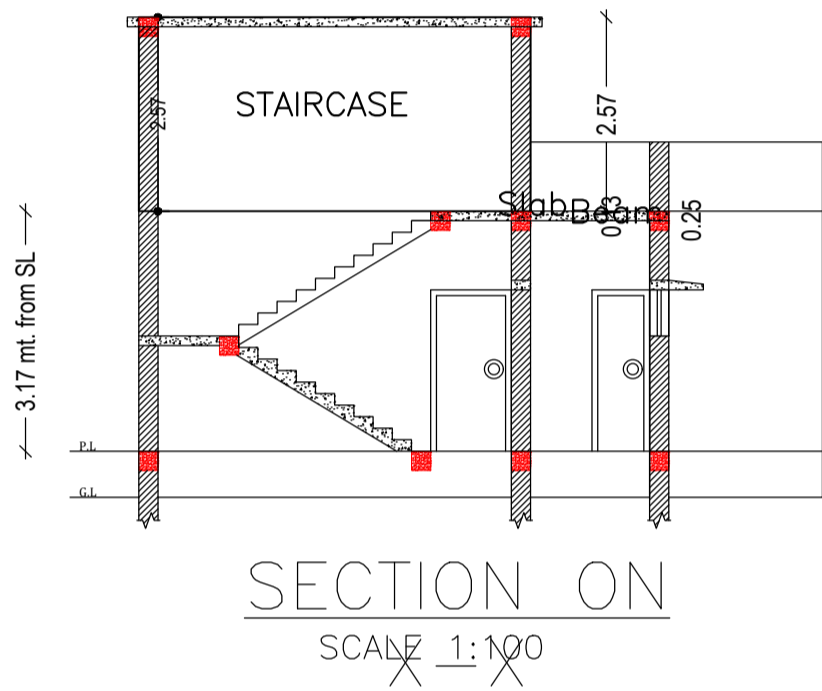

SECTION ON SCALE 1:100

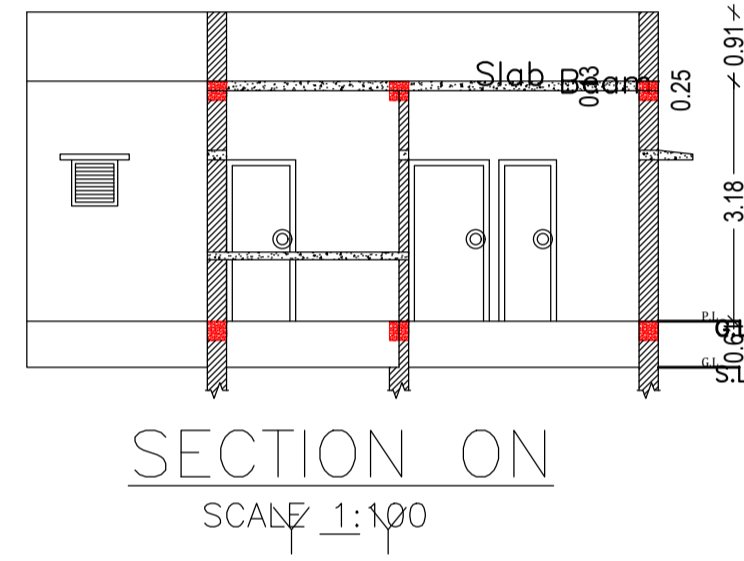

SECTION ON SCALE 1:100

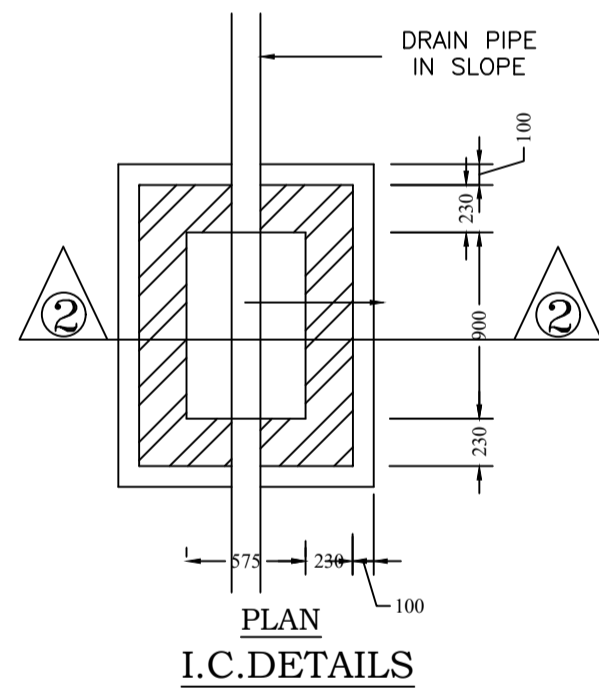

I.C. DETAILS

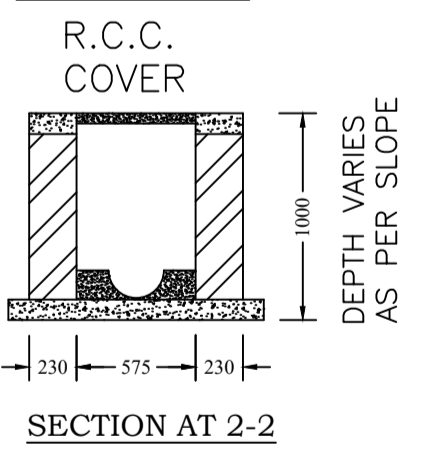

SECTION AT 2-2

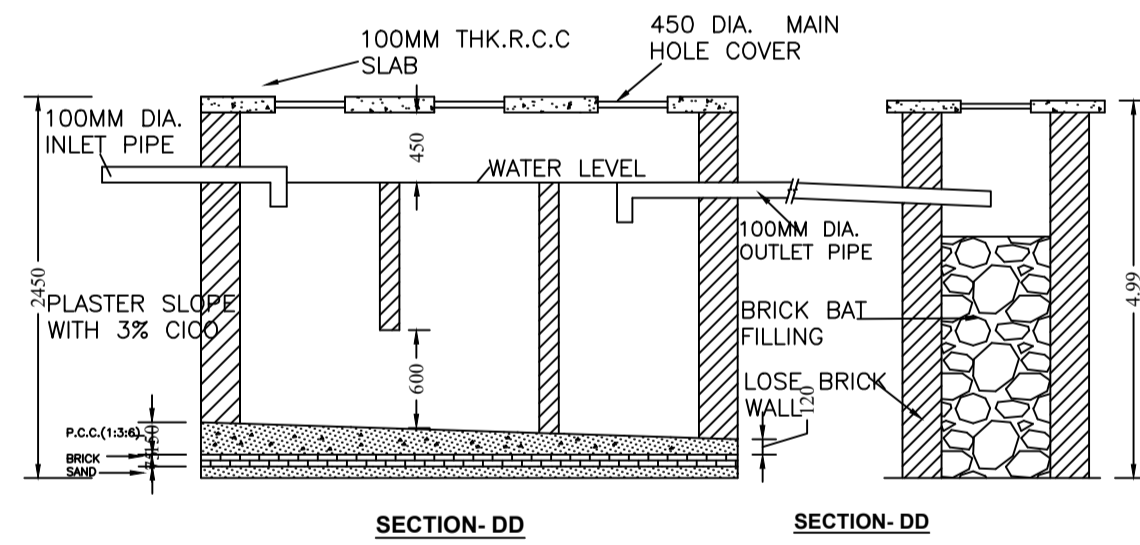

SECTION-DD

SECTION-DD

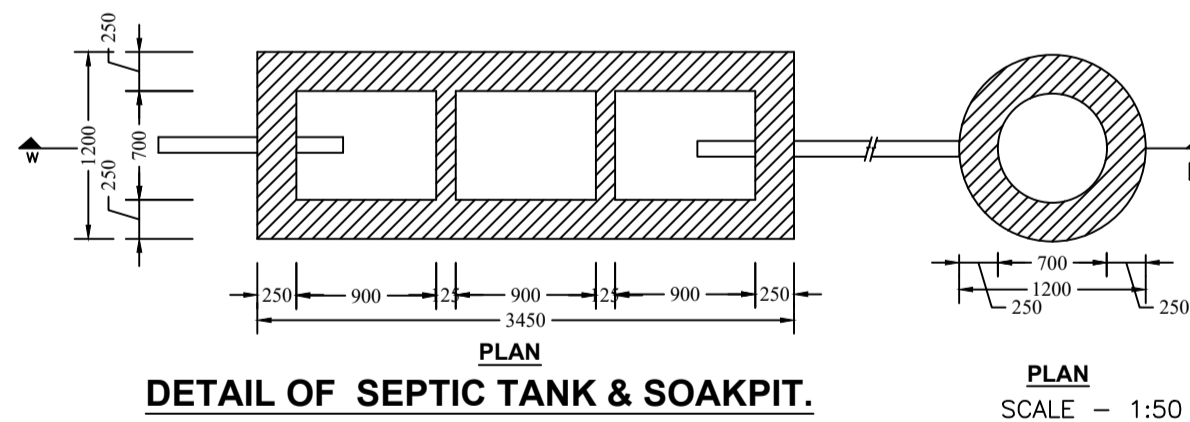

DETAIL OF SEPTIC TANK & SOAKPIT.

PLAN SCALE - 1:50

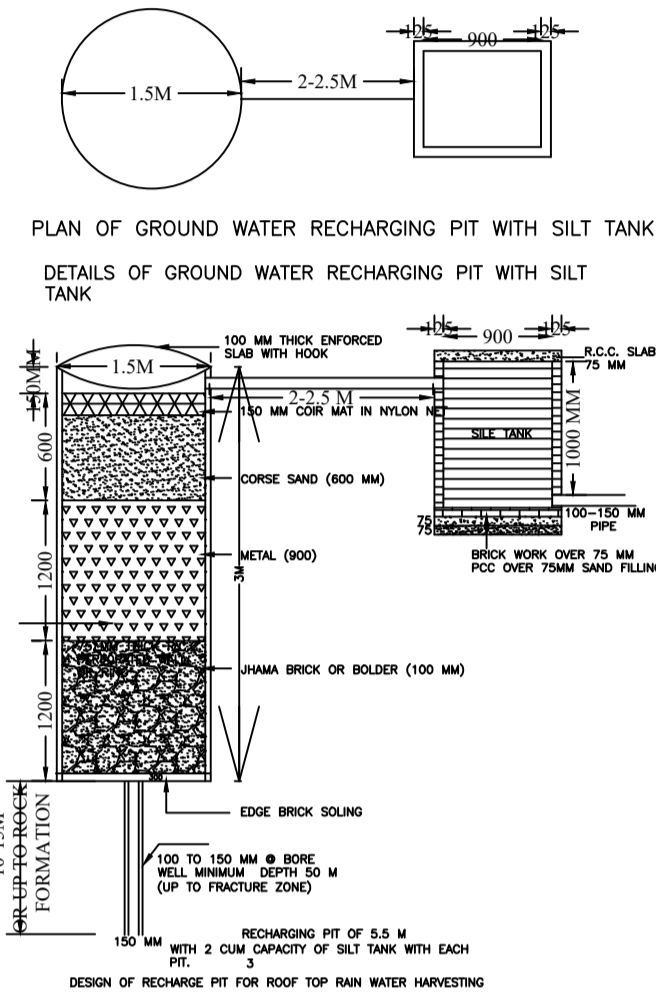

DETAILS OF GROUND WATER RECHARGING PIT WITH SILT TANK

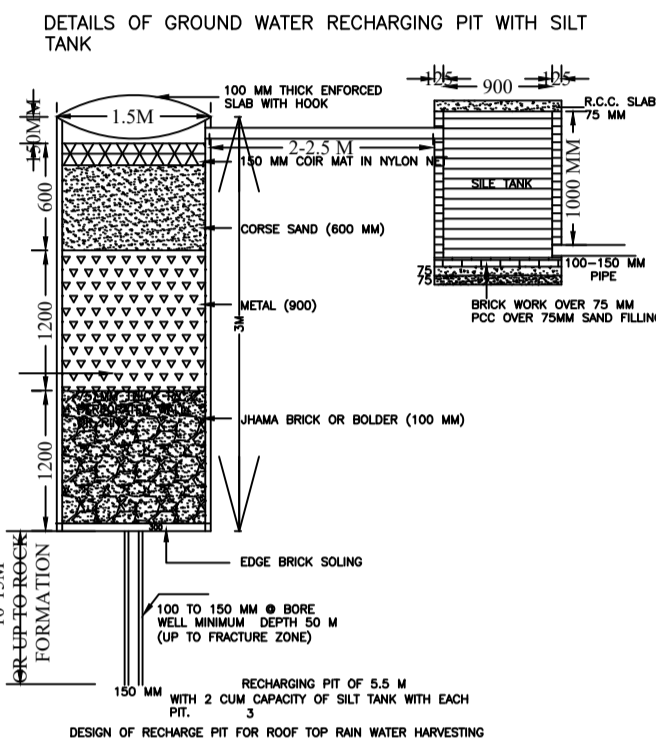

DESIGN OF RECHARGE PIT FOR ROOF TOP RAIN WATER HARVESTING

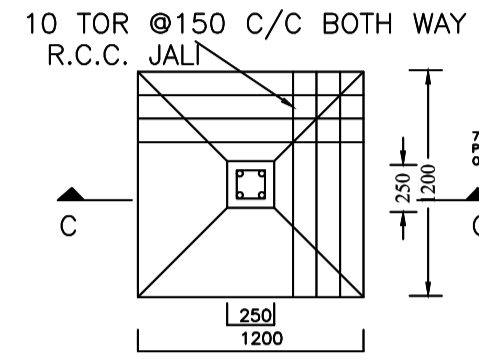

DETAIL OF FOUNDATION

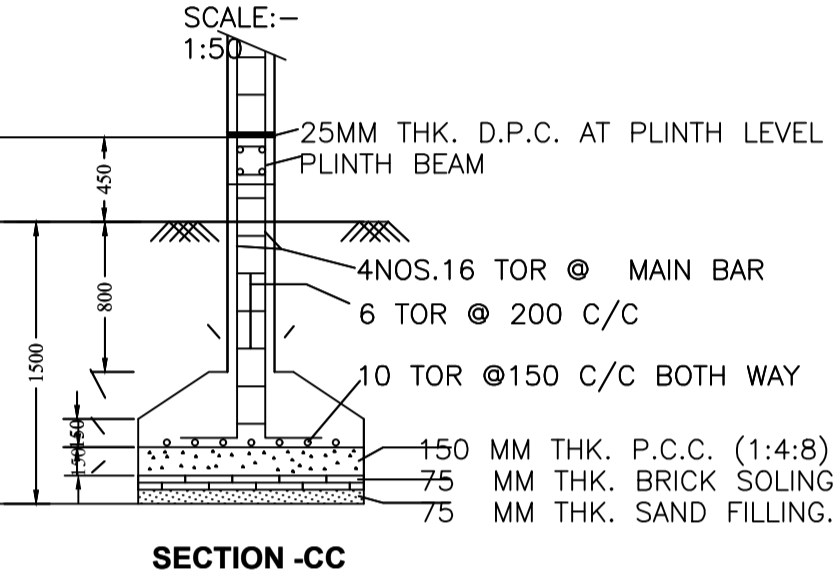

SECTION-CC

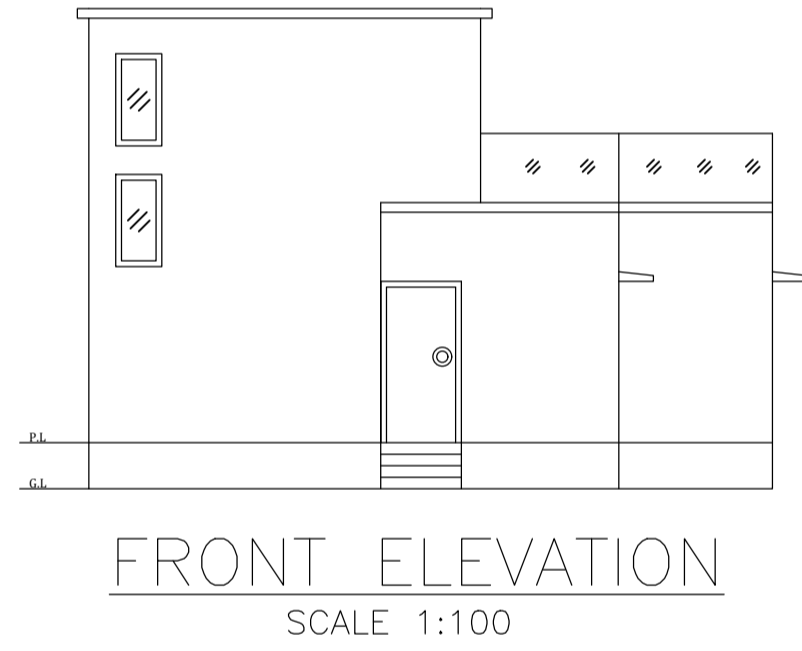

FRONT ELEVATION SCALE 1:100

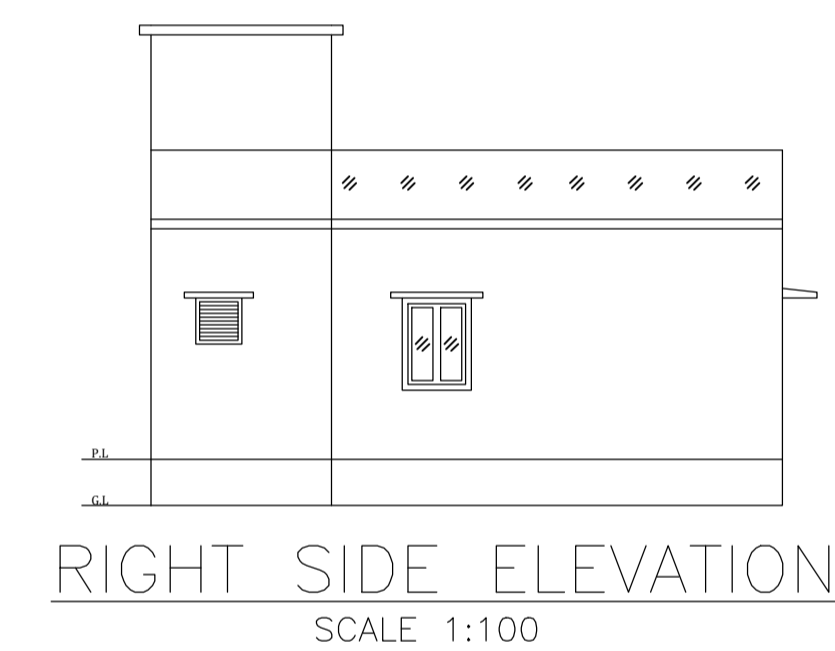

RIGHT SIDE ELEVATION SCALE 1:100

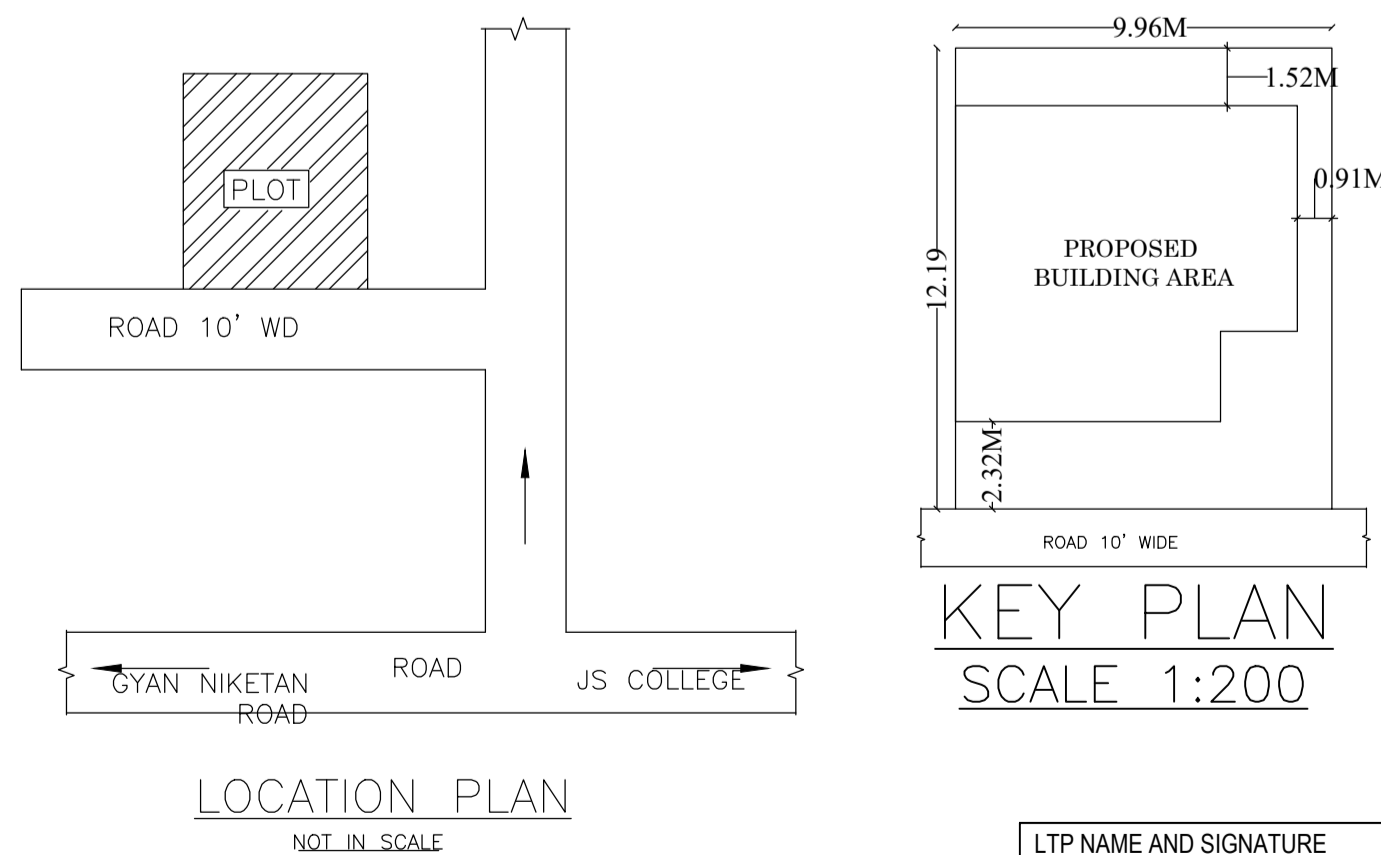

LOCATION PLAN NOT IN SCALE

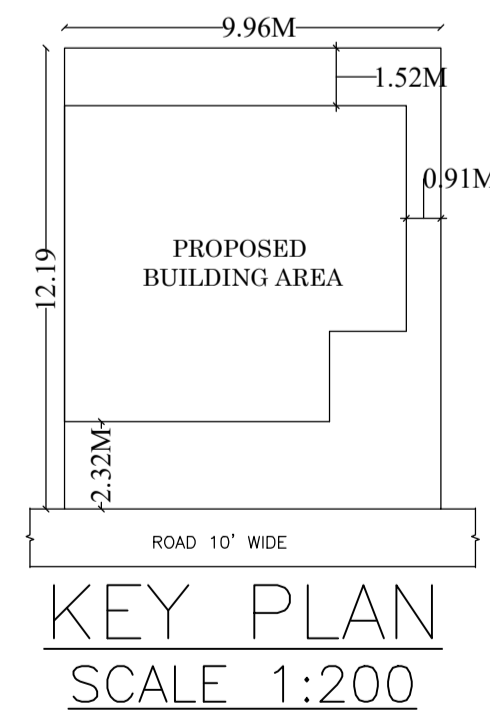

KEY PLAN SCALE 1:200

AREA STATEMENT		VERSION NO. : 1.0.68
MEDINAGAR MUNICIPAL CORPORATION		VERSION DATE: 16/10/2020
PROJECT DETAIL:		
Region : JHARKHAND URBAN LOCAL BODIES	Plot Use: Residential	
District : PALAMU	Plot SubUse: Bungalow/ Dwelling / Non Apartment	
Authority: MEDINAGAR MUNICIPAL CORPORATION	PlotNearbyReligiousStructure: NA	
Inward No: MNNP/BP/0033/W03/2024	Plot/SubPlot No: 145	
Application Type: General Proposal	North: -	
Project Type: Building Permission	South: -	
Nature of Development: New	East: -	
Location of Development Area: Old	West: -	
AREA DETAILS:		
AREA OF PLOT (Minimum)	(A)	SQ.MT. 121.39
Deduction for NetPlot Area		
Surrender Free of Cost		2.69
Total		2.69
NET AREA OF PLOT(Gross Plot Area - Deduction from Gross Plot area)	(A-Deductions)	118.70
Deduction for Balance Plot Area(from Gross Plot Area)		
Surrender Free of Cost		2.69
Common Plot		13.36
Total		16.05
BALANCE AREA OF PLOT(Net Plot Area - Recreational/Amenity space)	(A-Deductions)	105.34
PLOT AREA FOR COVERAGE(Net Plot Area)	(A-Deductions)	118.70
Plot Area for FAR (Net Plot Area + RoadWidening Area)	(A-Deductions)	121.39
COVERAGE CHECK		
Permissible Coverage area (70.00 %)		83.09
Proposed Coverage Area (59.54 %)		70.67
Total Prop. Coverage Area (59.54 %)		70.67
Balance coverage area (10.46 %)		12.42
FAR CHECK		
Perm. FAR Area (1.200)		145.67
Total Perm. FAR area		145.67
Residential FAR		70.67
Proposed FAR Area		70.67
Total Proposed FAR Area		70.67
Consumed FAR (Factor)		0.58
Balance FAR Area		75.00
BUILT UP AREA CHECK		
Total Proposed BuiltUp Area		70.67
ARCHITECT (Regd)	AYUSH RANJAN	
ENGINEER (Regd)		
SUPERVISOR (Regd)		
OWNER (Regd)	SHWETA DEVI	
DEVELOPMENT AUTHORITY		LOCAL BODY

COLOR INDEX	
PLOT BOUNDARY	Black
ABUTTING ROAD	Red
PROPOSED CONSTRUCTION	Green
COMMON PLOT	Yellow
ROAD WIDENING AREA	Blue
EXISTING (To be retained)	Orange
EXISTING (To be demolished)	Grey

Buildingwise Floor FAR Details

Floor Name	Building Name A1 (RESIDENTIAL)		Total	
	Proposed Built Up Area (Sq.mt.)	Proposed FAR Area (Sq.mt.)	Total Proposed Built Up Area (Sq.mt.)	Total FAR Area (Sq.mt.)
Ground Floor	70.67	70.67	70.67	70.67
Terrace Floor	0.00	0.00	0.00	0.00
Total :	70.67	70.67	70.67	70.67

Building USE/SUBUSE Details

Building Name	Building Use	Building SubUse	Building Structure
A1 (RESIDENTIAL)	Residential	Bungalow/ Dwelling / Non Apartment	Non-Highrise

Building :A1 (RESIDENTIAL)

Floor Name	Total Built Up Area (Sq.mt.)	Proposed FAR Area (Sq.mt.) Resi.	Total FAR Area (Sq.mt.)	Total Consumed Additional FAR Area (Sq.mt.)	Tnmt (No.)
Ground Floor	70.67	70.67	70.67	70.67	01
Terrace Floor	0.00	0.00	0.00	0.00	00
Total :	70.67	70.67	70.67	70.67	01
Total Number of Same Buildings :	1				
Total :	70.67	70.67	70.67	70.67	01

SCHEDULE OF DOOR:

BUILDING NAME	NAME	LENGTH	HEIGHT	NOS
A1 (RESIDENTIAL)	D2	0.76	2.13	02
A1 (RESIDENTIAL)	D1	0.91	2.13	01
A1 (RESIDENTIAL)	D	1.07	2.10	03

SCHEDULE OF WINDOW/VENTILATION:

BUILDING NAME	NAME	LENGTH	HEIGHT	NOS
A1 (RESIDENTIAL)	V	0.60	0.61	01
A1 (RESIDENTIAL)	V	0.61	0.61	01
A1 (RESIDENTIAL)	W1	0.91	1.22	01
A1 (RESIDENTIAL)	W	1.52	1.52	03

UnitBUA Table for Building :A1 (RESIDENTIAL)

FLOOR	Name	UnitBUA Type	UnitBUA Area	Carpet Area	No. of Rooms	No. of Tenement
GROUND FLOOR PLAN	SPLIT 1	FLAT	50.32	50.23	6	1
Total:	-	-	50.32	50.23	6	1

LTP NAME AND SIGNATURE	STRUCTURAL ENG'S NAME AND SIGNATURE	BUILDER NAME AND SIGNATURE	DIGITAL SIGNATURE
AYUSH RANJAN MNNP/ENG/0004/2023			