

SITE PLAN

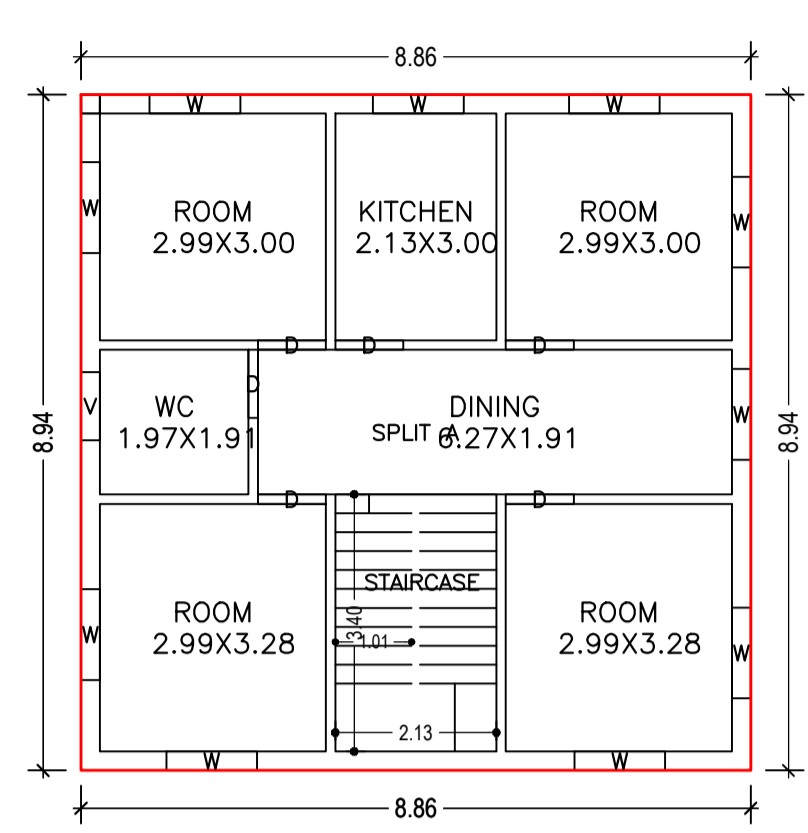

GROUND FLOOR PLAN (Proposed) (SCALE 1:100)

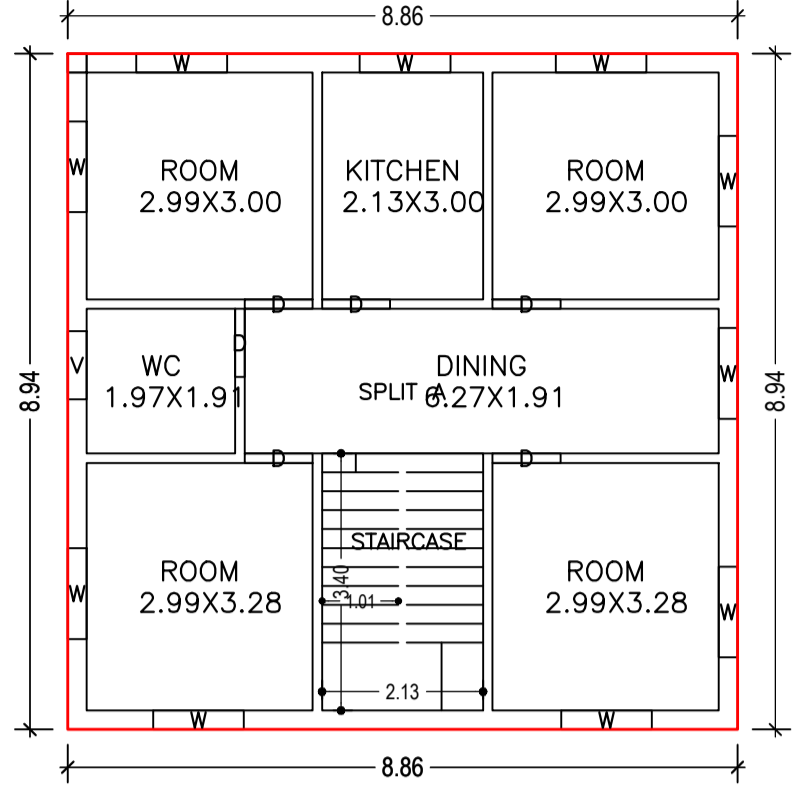

TYPICAL - 1&2 FLOOR PLAN (Proposed) (SCALE 1:100)

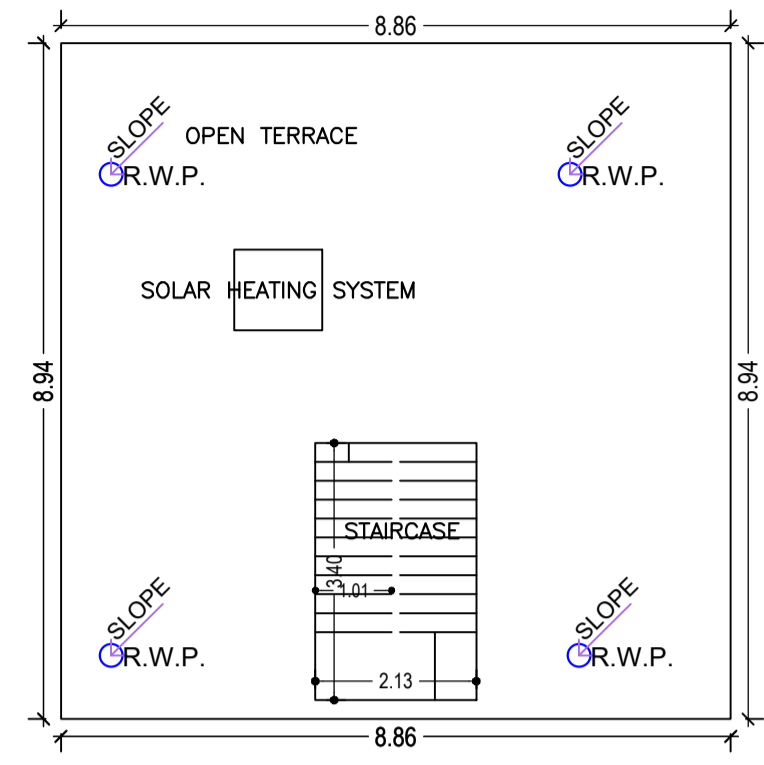

TERRACE FLOOR PLAN (SCALE 1:100)

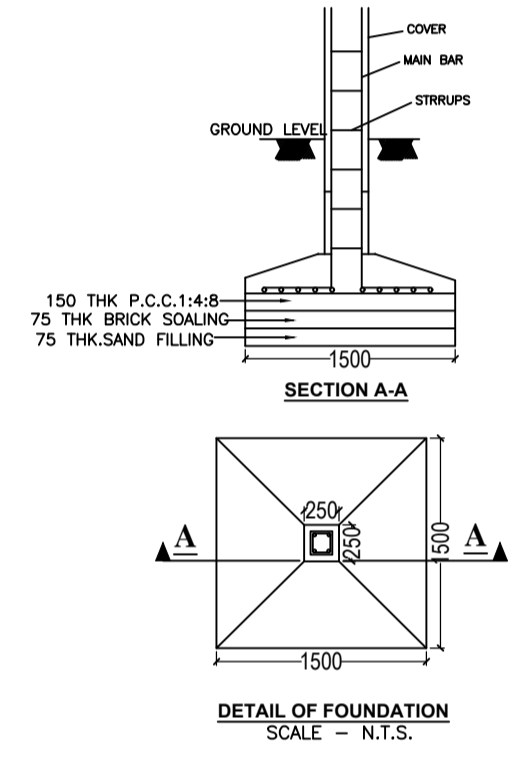

DETAIL OF FOUNDATION SCALE - N.T.S.

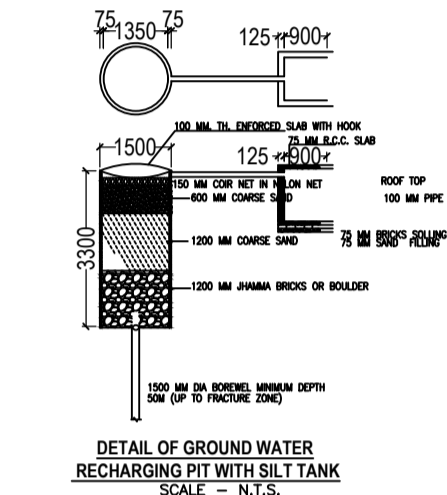

DETAIL OF GROUND WATER RECHARGING PIT WITH SILT TANK SCALE - N.T.S.

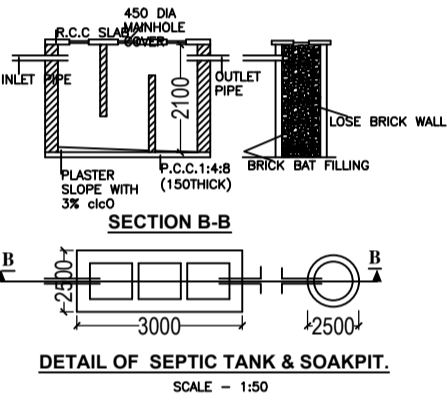

DETAIL OF SEPTIC TANK & SOAKPIT SCALE - 1:50

FAR & Tenement Details (Table 4c-1)

Building	No. of Same Bldg	Total Built Up Area (Sq.mt.)	Proposed FAR Area (Sq.mt.) Resi.	Total FAR Area (Sq.mt.)	Total Consumed Additional FAR Area (Sq.mt.)	Tnmt (No.)
A (BUILDING)	1	237.60	237.60	237.60	237.60	01
Grand Total :	1	237.60	237.60	237.60	237.60	01

Proposal Basic Information

Proposal File No.	MNNP/BI/0046/W06/2024
Owner Name	ARCHNA SINGH
Khata No	123
Plot No	1888
Village Name	Baralota
Use	Residential
SubUse	Bungalow Dwelling / Non Apartment

AREA STATEMENT

Area	Area (Sq.Mt.)
AREA OF PLOT (Minimum)	160.76
Deduction for NetPlot Area	
Surrender Free of Cost	13.01
Total	13.01
NET AREA OF PLOT(Gross Plot Area - Deduction from Gross Plot area)	147.76
Deduction for Balance Plot Area(from Gross Plot Area)	
Surrender Free of Cost	13.01
Common Plot	15.37
Total	28.37
BALANCE AREA OF PLOT(Net Plot Area - Recreational/Amenity space)	132.39
PLOT AREA FOR COVERAGE(Net Plot Area)	147.76
Plot Area for FAR (Net Plot Area + Road Widening Area)	160.76
COVERAGE CHECK	
Permissible Coverage area (70.00 %)	103.43
Proposed Coverage Area (53.60 %)	79.20
Total Prop. Coverage Area (53.6 %)	79.20
Balance coverage area (16.40 %)	24.23
FAR CHECK	
Perm. FAR Area (1500)	241.14
Total Perm. FAR area	241.14
Residential FAR	237.59
Proposed FAR Area	237.59
Total Proposed FAR Area	237.59
Consumed FAR (Factor)	1.48
Balance FAR Area	3.55
BUILT UP AREA CHECK	
Total Proposed BuiltUp Area	237.60
ARCHITECT (Regd)	PANKAJ KUMAR SINGH
ENGINEER (Regd)	
SUPERVISOR (Regd)	
OWNER (Regd)	ARCHNA SINGH
DEVELOPMENT AUTHORITY	LOCAL BODY

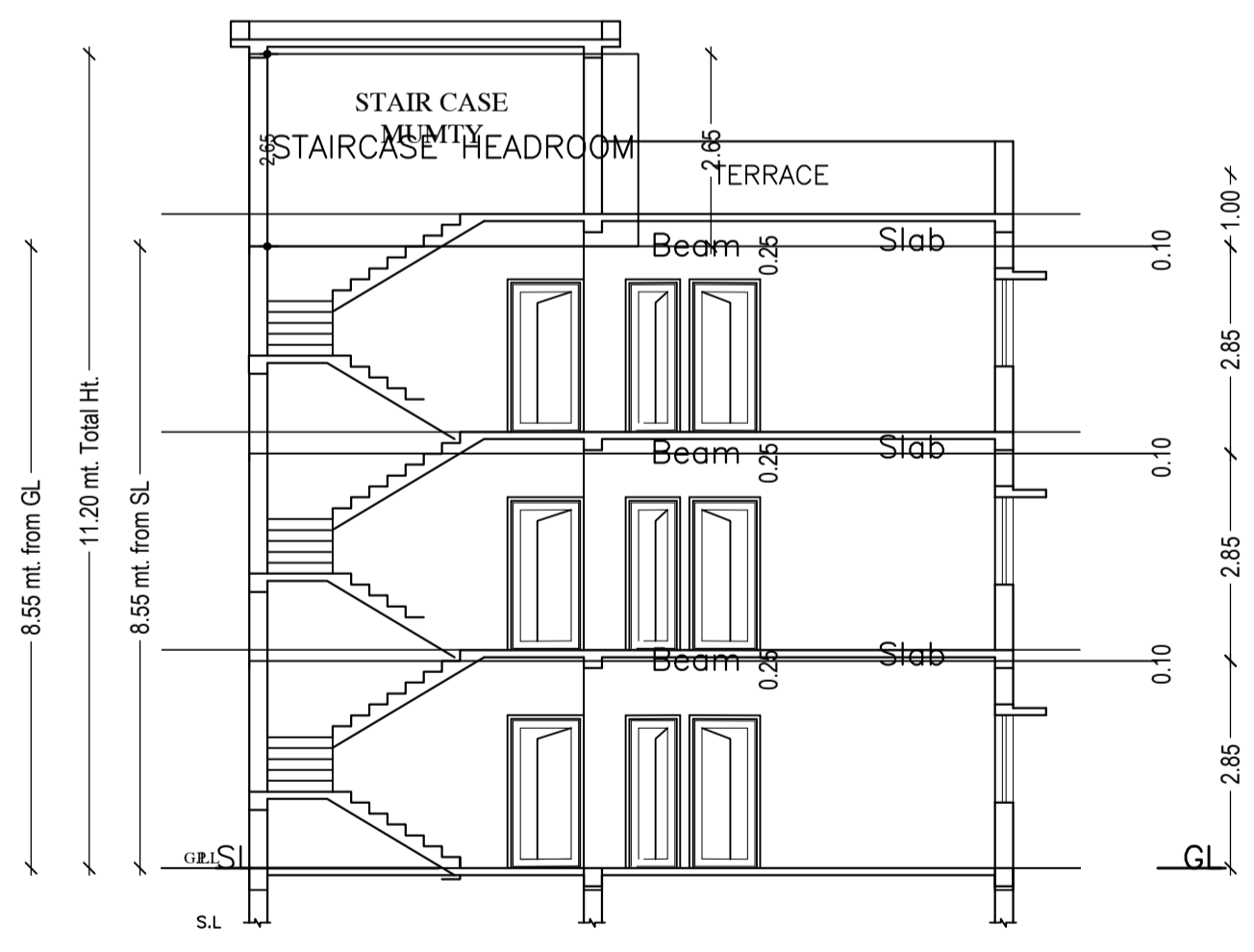

SECTION X-X Scale:1:100



RIGHT SIDE ELEVATION Scale:1:100

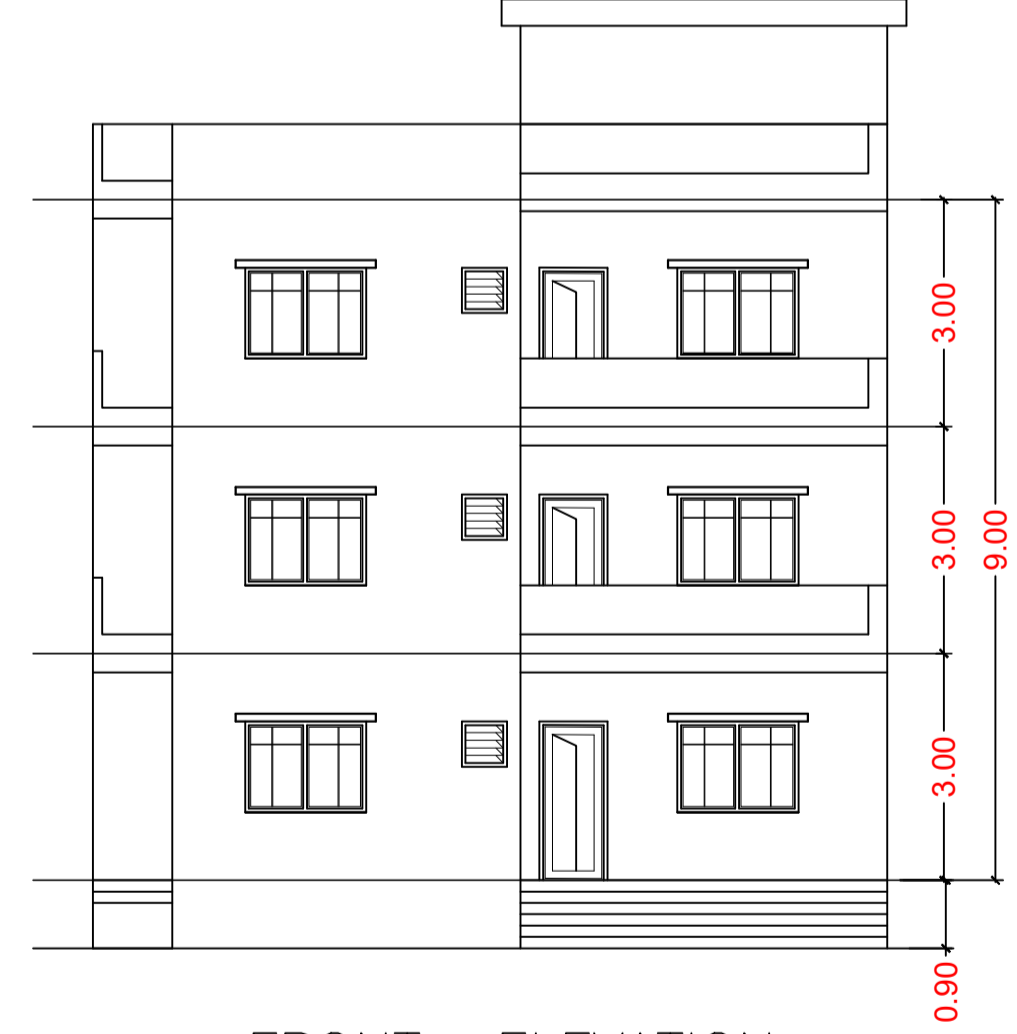

FRONT ELEVATION Scale:1:100

COLOR INDEX

PLOT BOUNDARY	Black
ABUTTING ROAD	Red
PROPOSED CONSTRUCTION	Green
COMMON PLOT	Yellow
ROAD WIDENING AREA	Blue
EXISTING (To be retained)	Orange
EXISTING (To be demolished)	Light Blue

Buildingwise Floor FAR Details

Floor Name	Building Name A (BUILDING)		Total	
	Proposed Built Up Area (Sq.mt.)	Proposed FAR Area (Sq.mt.)	Total Proposed Built Up Area (Sq.mt.)	Total FAR Area (Sq.mt.)
Ground Floor	79.20	79.20	79.20	79.20
First Floor	79.20	79.20	79.20	79.20
Second Floor	79.20	79.20	79.20	79.20
Terrace Floor	0.00	0.00	0.00	0.00
Total :	237.60	237.60	237.60	237.60

Building USE/SUBUSE Details

Building Name	Building Use	Building SubUse	Building Structure
A (BUILDING)	Residential	Bungalow Dwelling / Non Apartment	Non-Highrise

Building :A (BUILDING)

Floor Name	Total Built Up Area (Sq.mt.)	Proposed FAR Area (Sq.mt.) Resi.	Total FAR Area (Sq.mt.)	Total Consumed Additional FAR Area (Sq.mt.)	Tnmt (No.)
Ground Floor	79.20	79.20	79.20	79.20	01
First Floor	79.20	79.20	79.20	79.20	00
Second Floor	79.20	79.20	79.20	79.20	00
Terrace Floor	0.00	0.00	0.00	0.00	00
Total :	237.60	237.60	237.60	237.60	01
Total Number of Same Buildings	1				
Total :	237.60	237.60	237.60	237.60	01

SCHEDULE OF DOOR:

BUILDING NAME	NAME	LENGTH	HEIGHT	NOS
A (BUILDING)	D	0.90	2.10	18

SCHEDULE OF WINDOW/VENTILATION:

BUILDING NAME	NAME	LENGTH	HEIGHT	NOS
A (BUILDING)	V	0.90	0.60	03
A (BUILDING)	W	1.20	1.20	30

UnitBUA Table for Building :A (BUILDING)

FLOOR	Name	UnitBUA Type	UnitBUA Area	Carpet Area	No. of Rooms	No. of Tenement
GROUND FLOOR PLAN	SPLIT A	FLAT	214.27	214.08	7	1
TYPICAL - 1&2 FLOOR PLAN	SPLIT A	FLAT	0.00	0.00	7	0
Total:	-	-	214.27	214.08	21	1

LTP NAME AND SIGNATURE	STRUCTURAL ENG'S NAME AND SIGNATURE	BUILDER NAME AND SIGNATURE	DIGITAL SIGNATURE
PANKAJ KUMAR SINGH MNNP/ENG/0006/2019			

