

SITE PLAN

FAR & Tenement Details (Table 4c-1)

Building	No. of Same Bldg	Total Built Up Area (Sq.mt.)	Proposed FAR Area (Sq.mt.) Resi.	Total FAR Area (Sq.mt.)	Total Consumed Additional FAR Area (Sq.mt.)	Tnmt (No.)
A (BUILDING)	1	270.33	270.33	270.33	270.33	01
Grand Total :	1	270.33	270.33	270.33	270.33	01

Proposal Basic Information

Proposal File No.	MNNP/BP/0053/W20/2024
Owner Name	AKHILESH KUMAR SINGH
Khata No	376
Plot No	2670
Village Name	Redma
Use	Residential
SubUse	Bungalow Dwelling / Non Apartment

AREA STATEMENT	VERSION NO. : 1.0.68
MEDINAGAR MUNICIPAL CORPORATION	VERSION DATE: 16/10/2020
PROJECT DETAIL:	
Region : JHARKHAND URBAN LOCAL BODIES	Plot Use: Residential
District: PALANJU	Plot SubUse: Bungalow Dwelling / Non Apartment
Authority: MEDINAGAR MUNICIPAL CORPORATION	PlotNearbyReligiousStructure: NA
Inward No: MNNP/BP/0053/W20/2024	Plot/SubPlot No: 2670
Application Type: General Proposal	North: -
Project Type: Building Permission	South: -
Nature of Development: New	East: -
Location of Development Area: New	West: -
AREA DETAILS:	
AREA OF PLOT (Minimum)	(A) 150.62
Deduction for NetPlot Area	6.67
Surrender Free of Cost	6.67
Total	6.67
NET AREA OF PLOT(Gross Plot Area - Deduction from Gross Plot area)	(A-Deductions) 143.94
Deduction for Balance Plot Area(from Gross Plot Area)	
Surrender Free of Cost	6.67
Common Plot	10.32
Total	17.00
BALANCE AREA OF PLOT(Net Plot Area - Recreational/Amenity space)	(A-Deductions) 133.62
PLOT AREA FOR COVERAGE(Net Plot Area)	(A-Deductions) 143.94
Plot Area for FAR (Net Plot Area + RoadWidening Area)	(A-Deductions) 150.62
COVERAGE CHECK	
Permissible Coverage area (70.00 %)	100.76
Proposed Coverage Area (62.60 %)	90.11
Total Prop. Coverage Area (62.6 %)	90.11
Balance coverage area (7.40 %)	10.65
FAR CHECK	
Perm. FAR Area (1.800)	271.12
Total Perm. FAR area	271.12
Residential FAR	270.32
Proposed FAR Area	270.32
Total Proposed FAR Area	270.32
Consumed FAR (Factor)	1.79
Balance FAR Area	0.80
BUILT UP AREA CHECK	
Total Proposed BuiltUp Area	270.33
ARCHITECT (Regd)	AKASH SRIVASTAVA
ENGINEER (Regd)	
SUPERVISOR (Regd)	
OWNER (Regd)	AKHILESH KUMAR SINGH
DEVELOPMENT AUTHORITY	
	LOCAL BODY

COLOR INDEX	
PLOT BOUNDARY	Black
ABUTTING ROAD	Green
PROPOSED CONSTRUCTION	Red
COMMON PLOT	Yellow
ROAD WIDENING AREA	Blue
EXISTING (To be retained)	Orange
EXISTING (To be demolished)	Light Blue

Buildingwise Floor FAR Details

Floor Name	Building Name		Total	
	Proposed Built Up Area (Sq.mt.)	Proposed FAR Area (Sq.mt.)	Total Proposed Built Up Area (Sq.mt.)	Total FAR Area (Sq.mt.)
Ground Floor	90.11	90.11	90.11	90.11
First Floor	90.11	90.11	90.11	90.11
Second Floor	90.11	90.11	90.11	90.11
Terrace Floor	0.00	0.00	0.00	0.00
Total :	270.33	270.33	270.33	270.33

Building USE/SUBUSE Details

Building Name	Building Use	Building SubUse	Building Structure
A (BUILDING)	Residential	Bungalow Dwelling / Non Apartment	Non-Highrise

LTP NAME AND SIGNATURE	STRUCTURAL ENG'S NAME AND SIGNATURE	BUILDER NAME AND SIGNATURE	DIGITAL SIGNATURE
AKASH SRIVASTAVA MNNP/ENG/0009/2021			

Proposal Basic Information	
Proposal File No.	MNNP/BP/0053/W20/2024
Owner Name	AKHILESH KUMAR SINGH
Khata No	376
Plot No	2670
Village Name	Redma
Use	Residential
SubUse	Bungalow/ Dwelling / Non Apartment

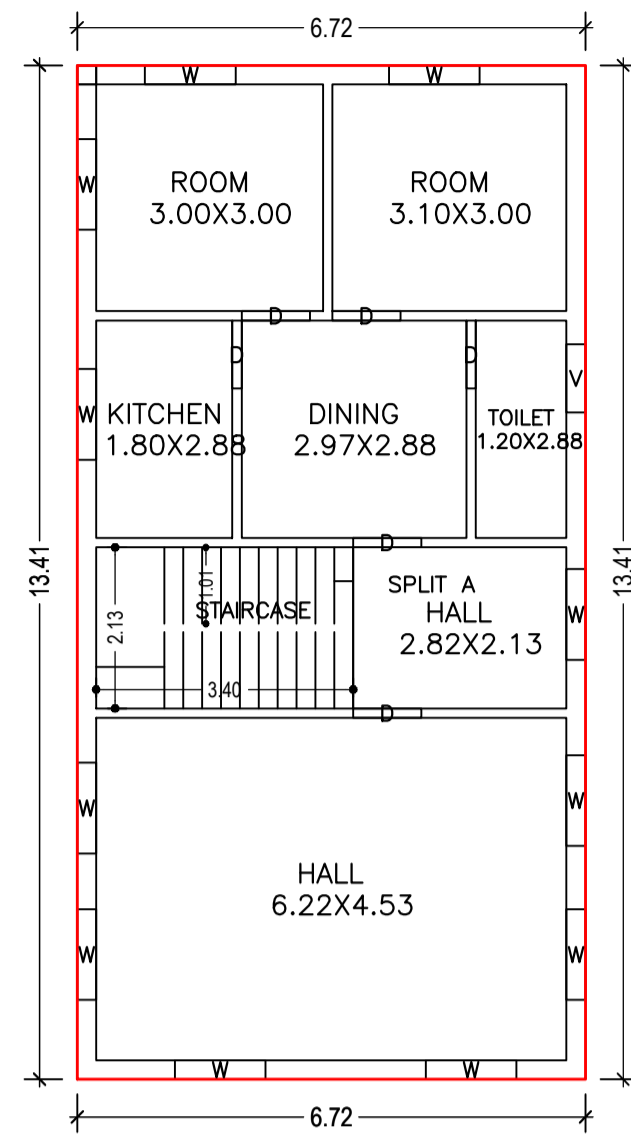

GROUND FLOOR PLAN (Proposed) (SCALE 1:100)

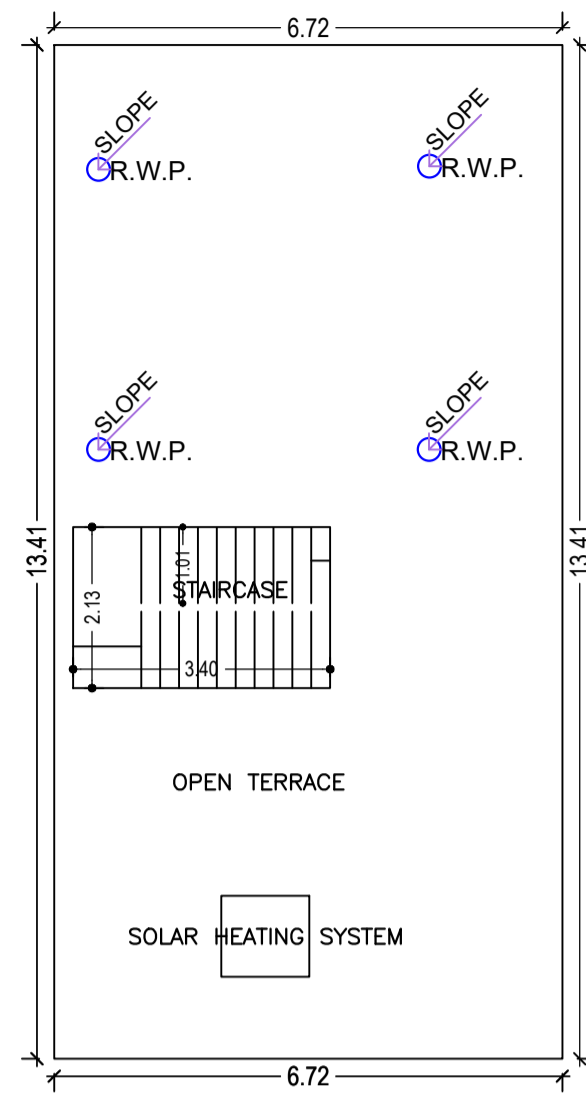

TERRACE FLOOR PLAN (SCALE 1:100)

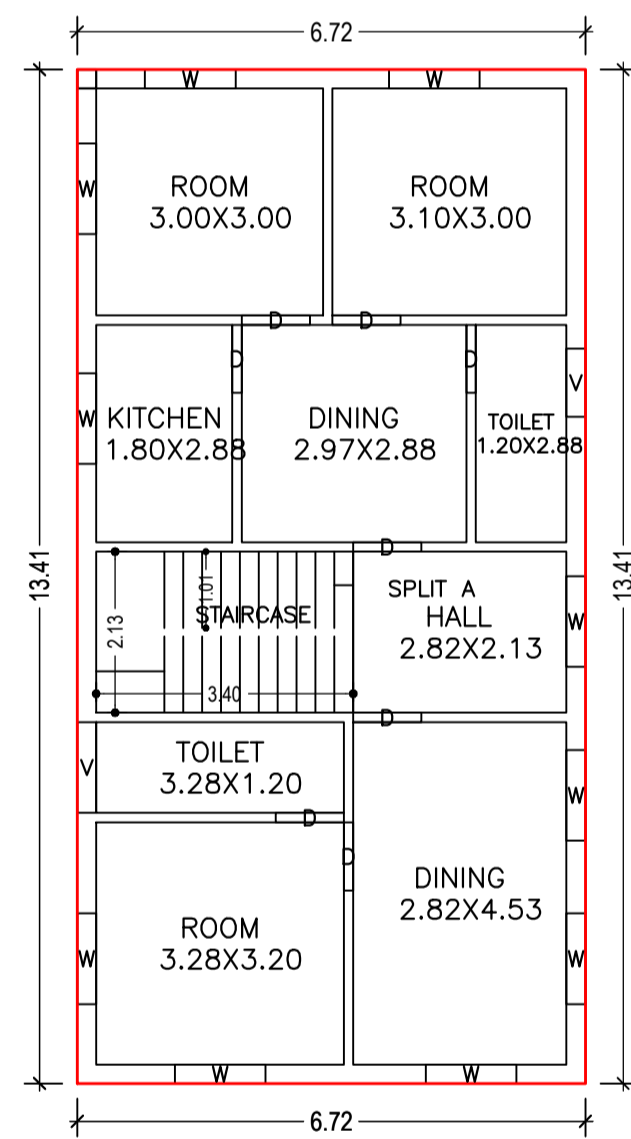

TYPICAL -1&2 FLOOR PLAN (Proposed) (SCALE 1:100)

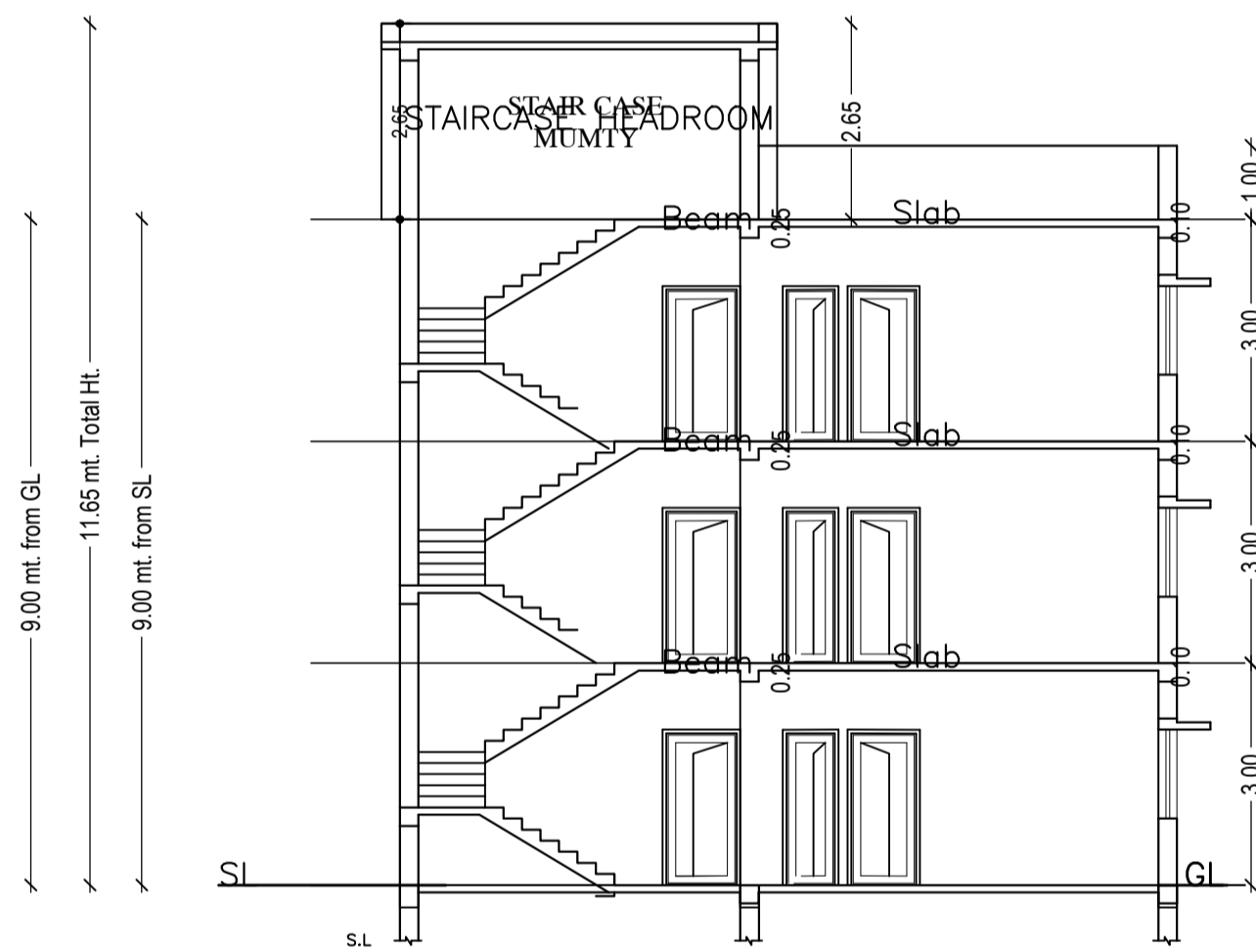

SECTION X-X Scale 1:100



FRONT ELEVATION Scale 1:100



RIGHT SIDE ELEVATION Scale 1:100

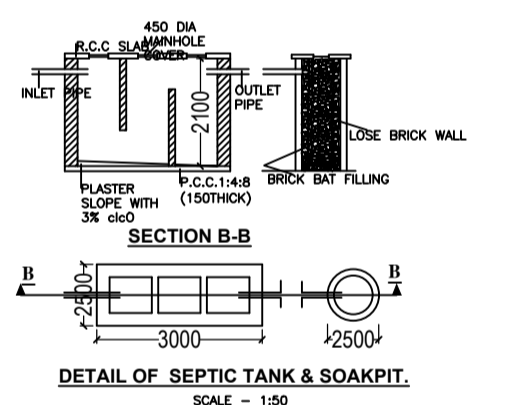
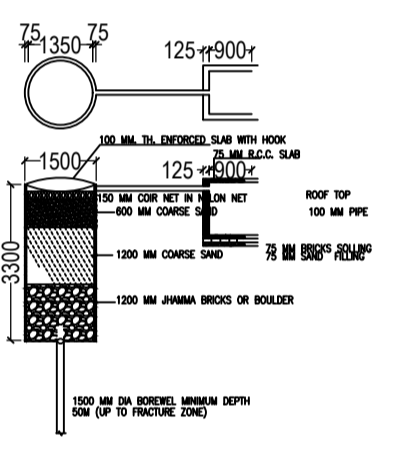
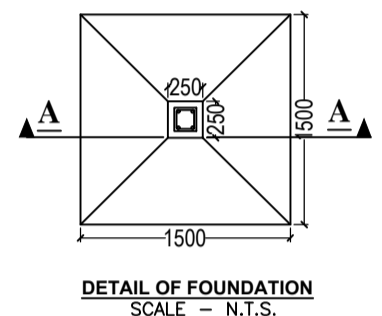
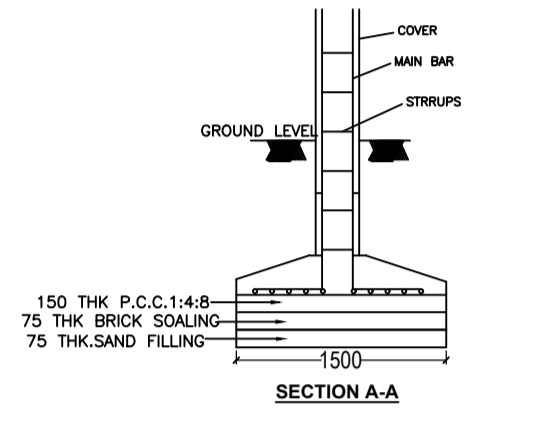

Building :A (BUILDING)

Floor Name	Total Built Up Area (Sq.mt.)	Proposed FAR Area (Sq.mt.) Resi.	Total FAR Area (Sq.mt.)	Total Consumed Additional FAR Area (Sq.mt.)	Tnmt (No.)
Ground Floor	90.11	90.11	90.11	90.11	01
First Floor	90.11	90.11	90.11	90.11	00
Second Floor	90.11	90.11	90.11	90.11	00
Terrace Floor	0.00	0.00	0.00	0.00	00
Total :	270.33	270.33	270.33	270.33	01
Total Number of Same Buildings :	1				
Total :	270.33	270.33	270.33	270.33	01

SCHEDULE OF DOOR:

BUILDING NAME	NAME	LENGTH	HEIGHT	NOS
A (BUILDING)	D	0.90	2.10	22

SCHEDULE OF WINDOW/VENTILATION:

BUILDING NAME	NAME	LENGTH	HEIGHT	NOS
A (BUILDING)	V	0.90	0.60	03
A (BUILDING)	W	1.20	1.20	31
A (BUILDING)	V	1.20	1.20	02

UnitBUA Table for Building :A (BUILDING)

FLOOR	Name	UnitBUA Type	UnitBUA Area	Carpet Area	No. of Rooms	No. of Tenement
GROUND FLOOR PLAN	SPLIT A	FLAT	247.00	246.81	7	1
TYPICAL -1&2 FLOOR PLAN	SPLIT A	FLAT	0.00	0.00	9	0
Total:	-	-	247.00	246.81	25	1

LTP NAME AND SIGNATURE	STRUCTURAL ENG'S NAME AND SIGNATURE	BUILDER NAME AND SIGNATURE	DIGITAL SIGNATURE
AKASH SRIVASTAVA MNNP/ENG/0009/2021			