

SITE PLAN

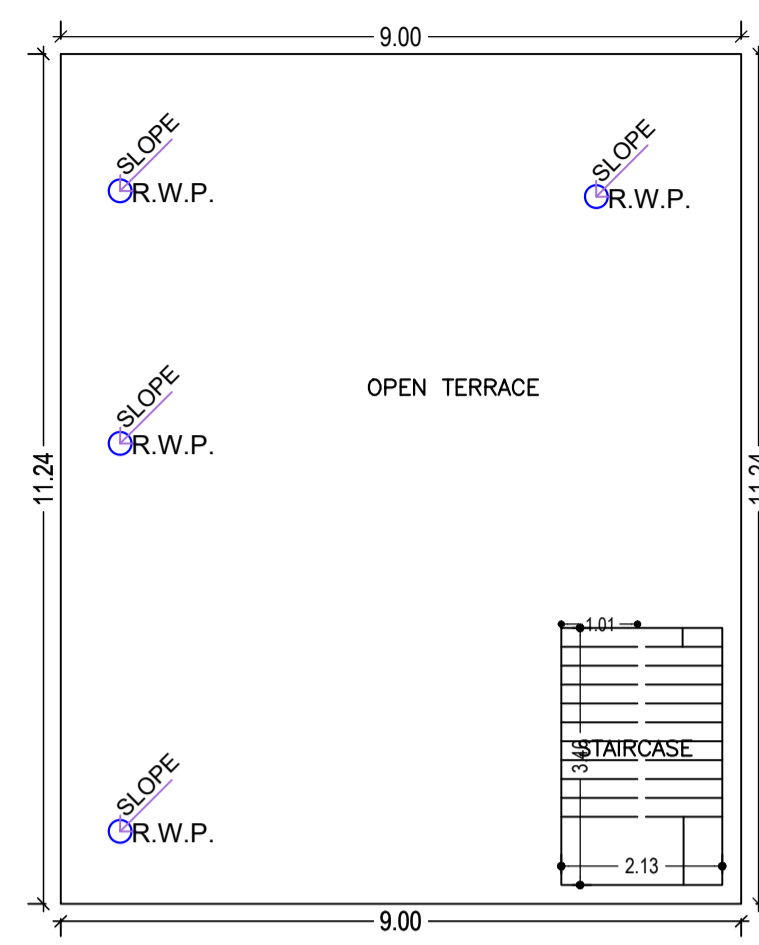

TERRACE FLOOR PLAN (SCALE 1:100)

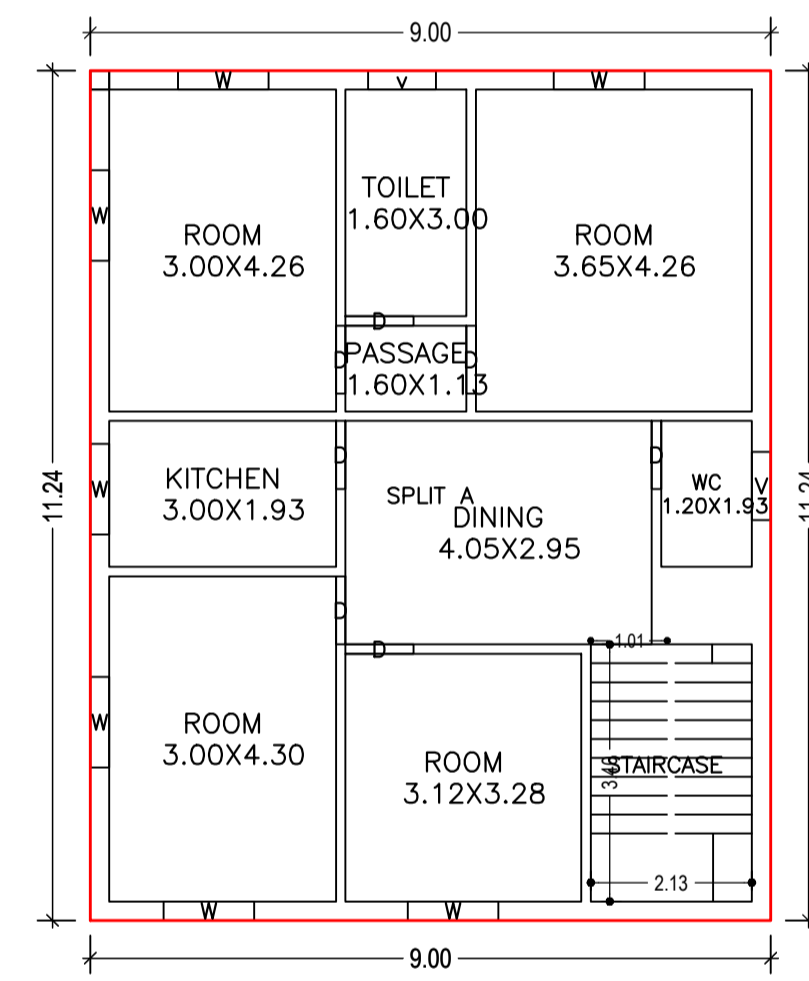

GROUND FLOOR PLAN (Proposed) (SCALE 1:100)

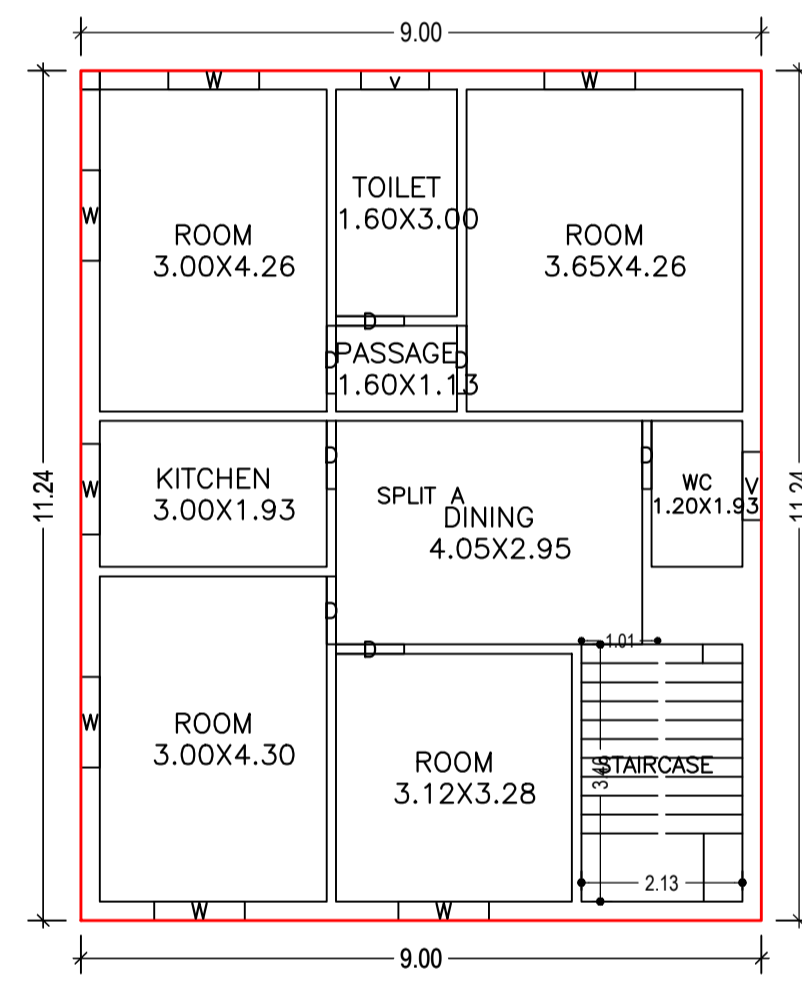

FIRST FLOOR PLAN (Proposed) (SCALE 1:100)

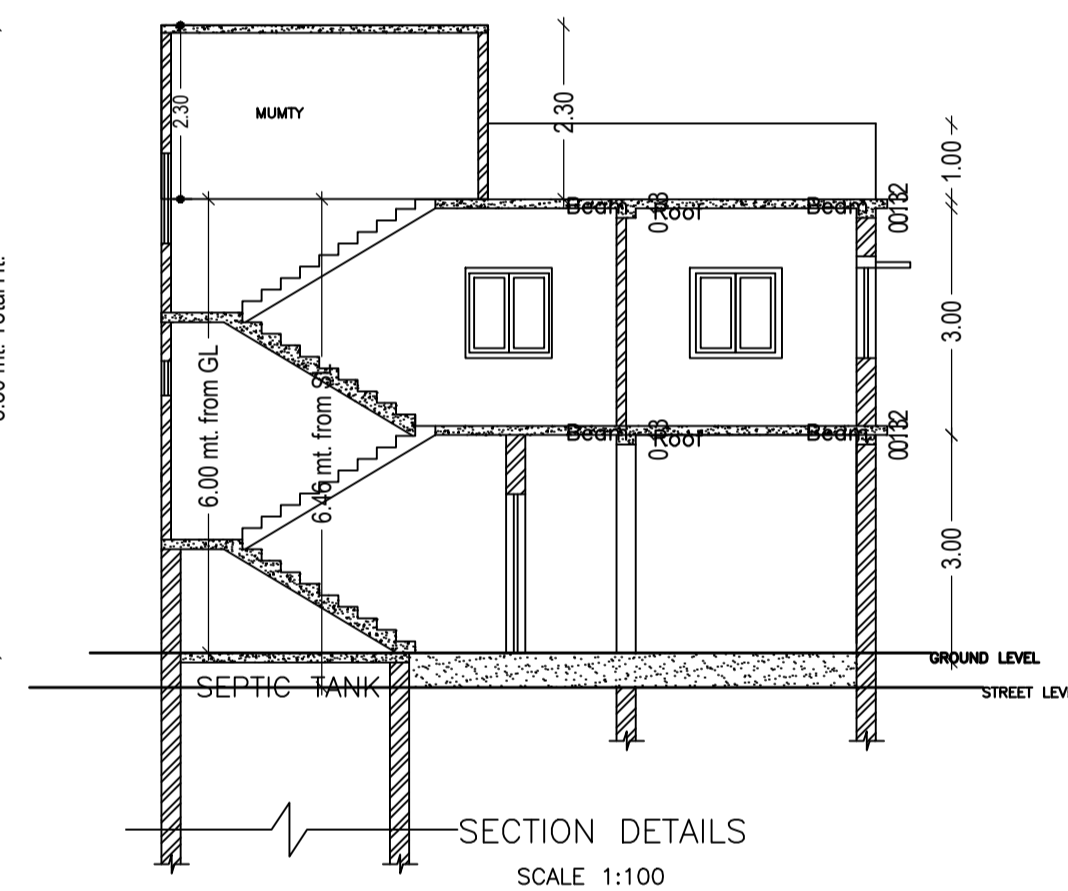

SECTION DETAILS (SCALE 1:100)

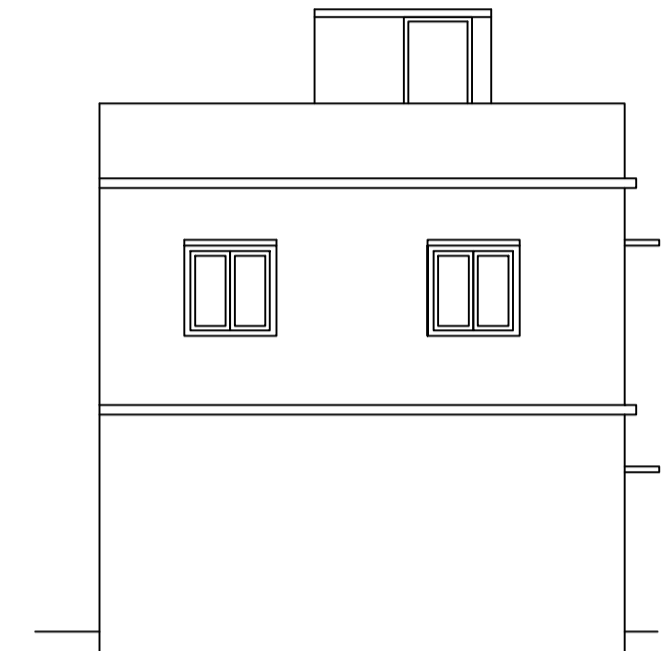

BACK ELEVATION (SCALE 1:100)

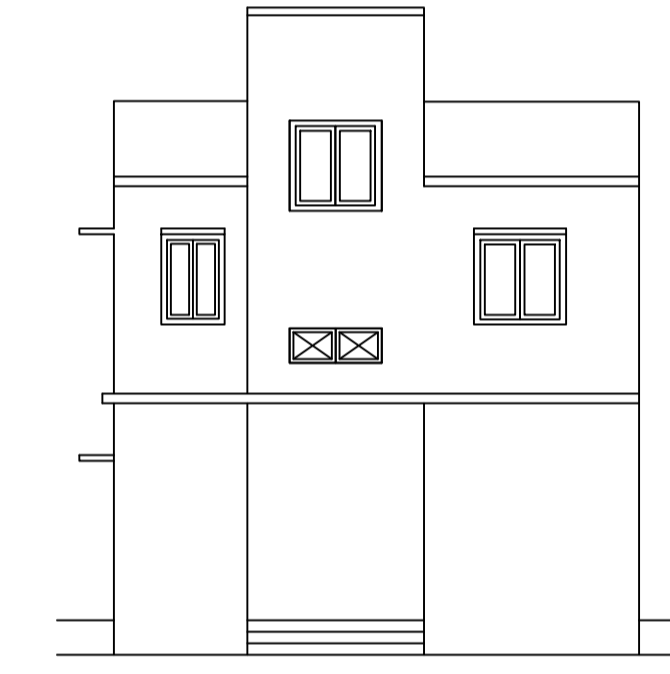

FRONT ELEVATION (SCALE 1:100)

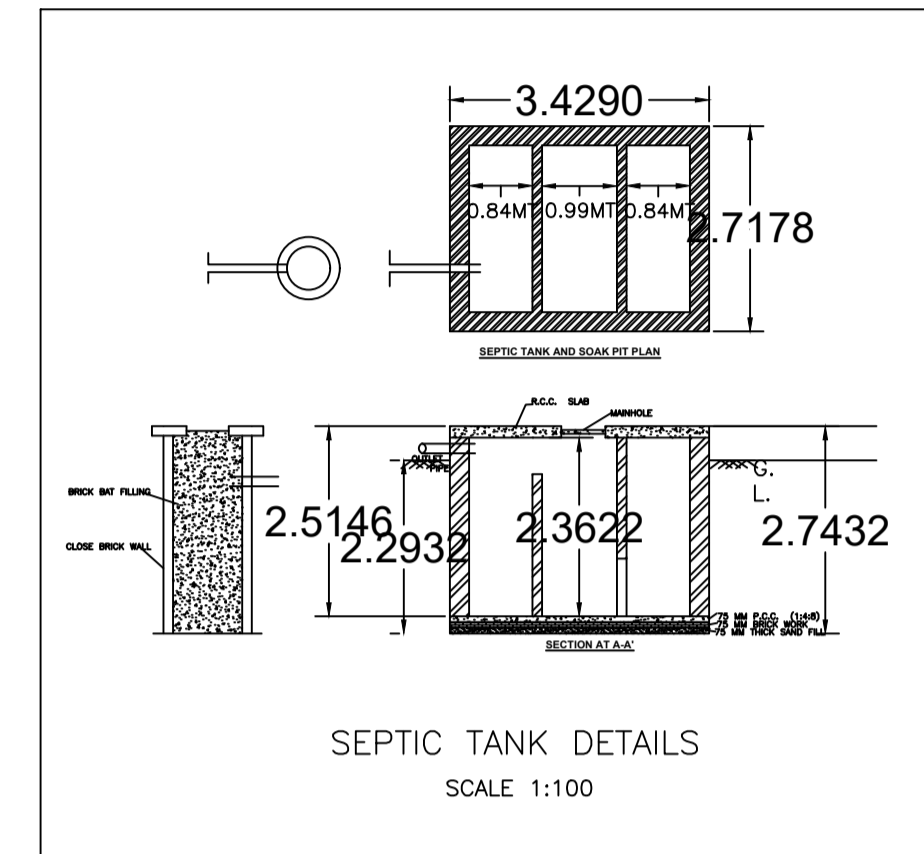

SEPTIC TANK DETAILS (SCALE 1:100)

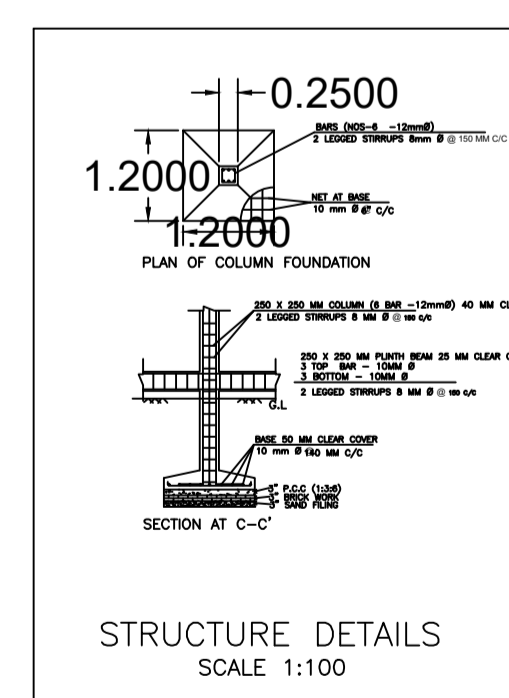

STRUCTURE DETAILS (SCALE 1:100)

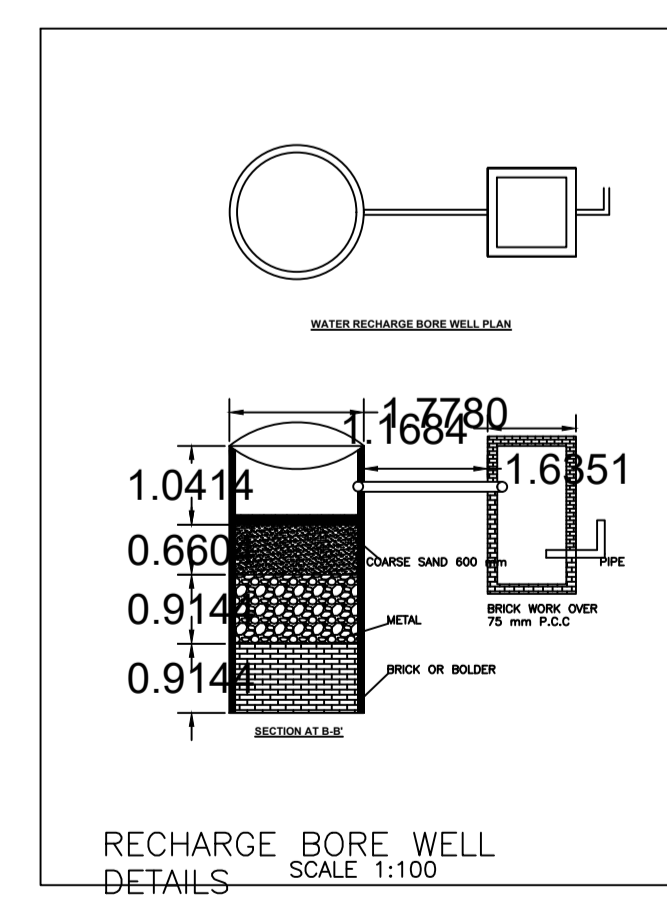

RECHARGE BORE WELL DETAILS (SCALE 1:100)

FAR & Tenement Details (Table 4c-1)

Building	No. of Same Bldg	Total Built Up Area (Sq.mt.)	Proposed FAR Area (Sq.mt.) Resi.	Total FAR Area (Sq.mt.)	Total Consumed Additional FAR Area (Sq.mt.)	Tnmt (No.)
A (BUILDING)	1	202.32	202.32	202.32	202.32	01
Grand Total :	1	202.32	202.32	202.32	202.32	01

Proposal Basic Information

Proposal File No.	MNNP/0056/W08/2024
Owner Name	RANJEET KUMAR SINGH
Khata No	1
Plot No	138
Village Name	Baralota
Use	Residential
SubUse	Bungalow/ Dwelling / Non Apartment

AREA STATEMENT		VERSION NO. : 1.0.68
MEDINAGAR MUNICIPAL CORPORATION		VERSION DATE: 16/10/2020
PROJECT DETAIL:		
Region : JHARKHAND URBAN	Plot Use: Residential	
Local Bodies : District : PALAMU	Plot SubUse: Bungalow/ Dwelling / Non Apartment	
Authority: MEDINAGAR MUNICIPAL CORPORATION	Plot/Nearby/Religious/Structure: NA	
Inward No: MNNP/0056/W08/2024	Plot/SubPlot No: 138	
Application Type: General Proposal	North: -	
Project Type: Building Permission	South: -	
Nature of Development: New	East: -	
Location of Development Area: New	West: -	
AREA DETAILS:		
AREA OF PLOT (Minimum)	(A)	SQ.MT. 150.88
NET AREA OF PLOT(Gross Plot Area - Deduction from Gross Plot area)	(A-Deductions)	150.88
Deduction for Balance Plot Area(from Gross Plot Area)		
Common Plot		13.26
Total		13.26
BALANCE AREA OF PLOT(Net Plot Area - Recreational/Amenity space)	(A-Deductions)	137.62
PLOT AREA FOR COVERAGE(Net Plot Area)	(A-Deductions)	150.88
Plot Area for FAR (Net Plot Area + Road Widening Area)	(A-Deductions)	150.88
COVERAGE CHECK		
Permissible Coverage area (70.00 %)		105.62
Proposed Coverage Area (67.05 %)		101.16
Total Prop. Coverage Area (67.05 %)		101.16
Balance coverage area (2.96 %)		4.46
FAR CHECK		
Perm. FAR Area (2.000)		301.76
Total Perm. FAR area		301.76
Residential FAR		202.32
Proposed FAR Area		202.32
Total Proposed FAR Area		202.32
Consumed FAR (Factor)		1.34
Balance FAR Area		99.44
BUILT UP AREA CHECK		
Total Proposed BuiltUp Area		202.32
ARCHITECT (Regd) PANKAJ KUMAR SINGH		
ENGINEER (Regd)		
SUPERVISOR (Regd)		
OWNER (Regd) RANJEET KUMAR SINGH		
DEVELOPMENT AUTHORITY		LOCAL BODY

COLOR INDEX	
PLOT BOUNDARY	Black
ABUTTING ROAD	Red
PROPOSED CONSTRUCTION	Green
COMMON PLOT	Yellow
ROAD WIDENING AREA	Blue
EXISTING (To be retained)	Orange
EXISTING (To be demolished)	Grey

Buildingwise Floor FAR Details

Floor Name	Building Name A (BUILDING)		Total	
	Proposed Built Up Area (Sq.mt.)	Proposed FAR Area (Sq.mt.)	Total Proposed Built Up Area (Sq.mt.)	Total FAR Area (Sq.mt.)
Ground Floor	101.16	101.16	101.16	101.16
First Floor	101.16	101.16	101.16	101.16
Terrace Floor	0.00	0.00	0.00	0.00
Total :	202.32	202.32	202.32	202.32

Building USE/SUBUSE Details

Building Name	Building Use	Building SubUse	Building Structure
A (BUILDING)	Residential	Bungalow/ Dwelling / Non Apartment	Non-Highrise

Building :A (BUILDING)

Floor Name	Total Built Up Area (Sq.mt.)	Proposed FAR Area (Sq.mt.) Resi.	Total FAR Area (Sq.mt.)	Total Consumed Additional FAR Area (Sq.mt.)	Tnmt (No.)
Ground Floor	101.16	101.16	101.16	101.16	01
First Floor	101.16	101.16	101.16	101.16	00
Terrace Floor	0.00	0.00	0.00	0.00	00
Total :	202.32	202.32	202.32	202.32	01
Total Number of Same Buildings :	1				
Total :	202.32	202.32	202.32	202.32	01

SCHEDULE OF DOOR:

BUILDING NAME	NAME	LENGTH	HEIGHT	NOS
A (BUILDING)	D	0.90	2.10	14

SCHEDULE OF WINDOW/VENTILATION:

BUILDING NAME	NAME	LENGTH	HEIGHT	NOS
A (BUILDING)	v	0.90	0.60	02
A (BUILDING)	V	0.90	0.60	02
A (BUILDING)	W	1.20	1.20	14

UnitBUA Table for Building :A (BUILDING)

FLOOR	Name	UnitBUA Type	UnitBUA Area	Carpel Area	No. of Rooms	No. of Tenement
GROUND FLOOR PLAN	SPLIT A	FLAT	184.95	184.82	9	1
FIRST FLOOR PLAN	SPLIT A	FLAT	0.00	0.00	9	0
Total:	-	-	184.95	184.82	18	1

LTP NAME AND SIGNATURE	STRUCTURAL ENG'S NAME AND SIGNATURE	BUILDER NAME AND SIGNATURE	DIGITAL SIGNATURE
PANKAJ KUMAR SINGH MNNP/ENG/006/2019			