

Proposal Basic Information

Proposal File No.	MNNP/BP/0051/W03/2024
Owner Name	SUNIL KUMAR PATEL
Khata No	38
Plot No	13
Village Name	Nimiya
Use	Residential
SubUse	Bungalow Dwelling / Non Apartment

FAR & Tenement Details (Table 4c-1)

Building	No. of Same Bldg	Total Built Up Area (Sq.mt.)	Proposed FAR Area (Sq.mt.) Resi.	Total FAR Area (Sq.mt.)	Total Consumed Additional FAR Area (Sq.mt.)	Tnmt (No.)
A (BUILDING)	1	140.68	140.68	140.68	140.68	01
Grand Total :	1	140.68	140.68	140.68	140.68	01

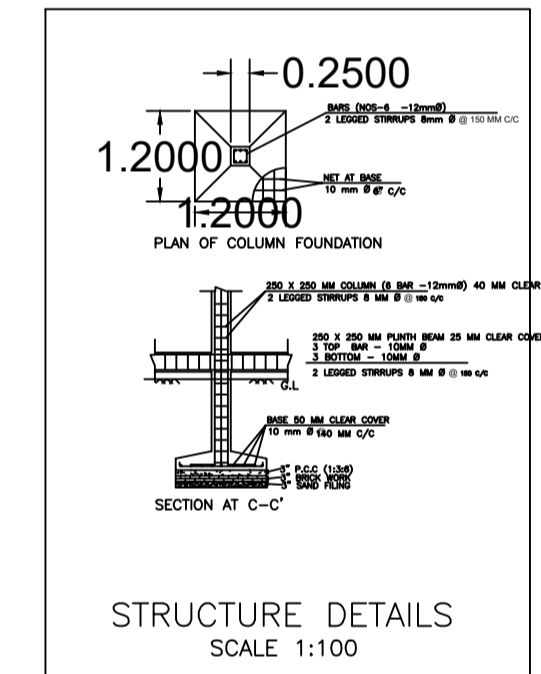
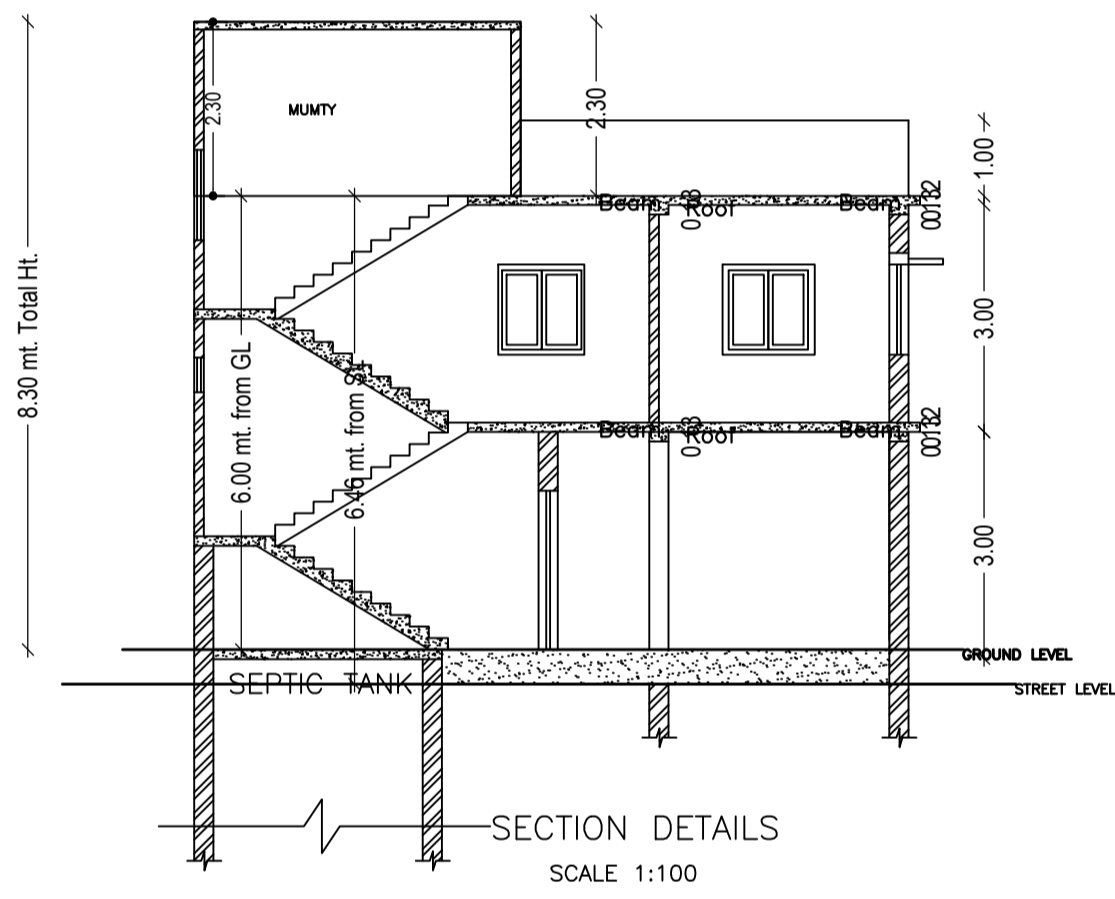
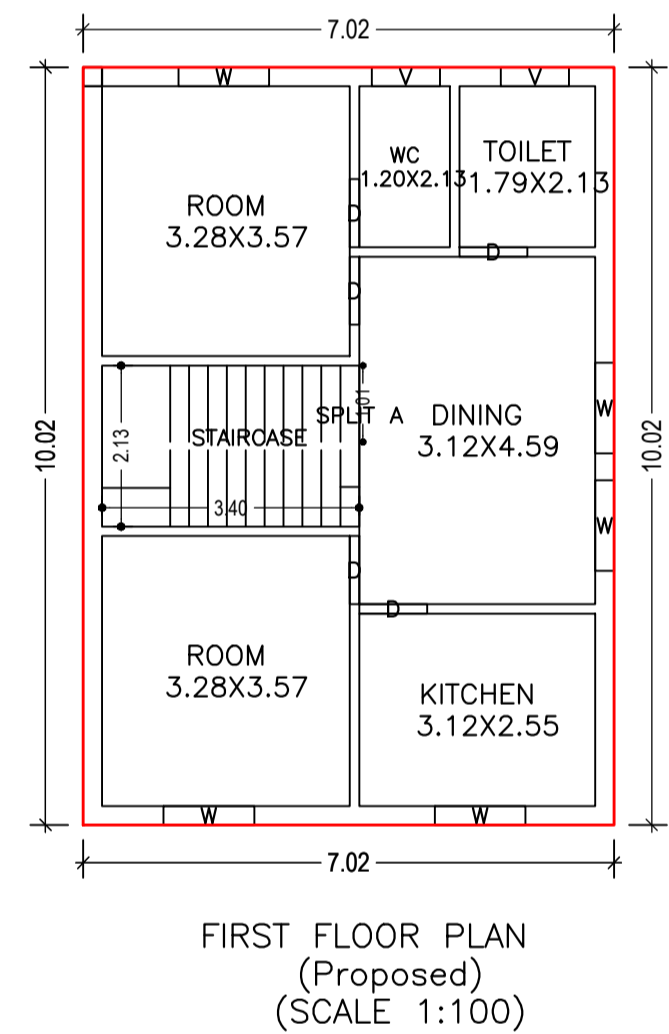
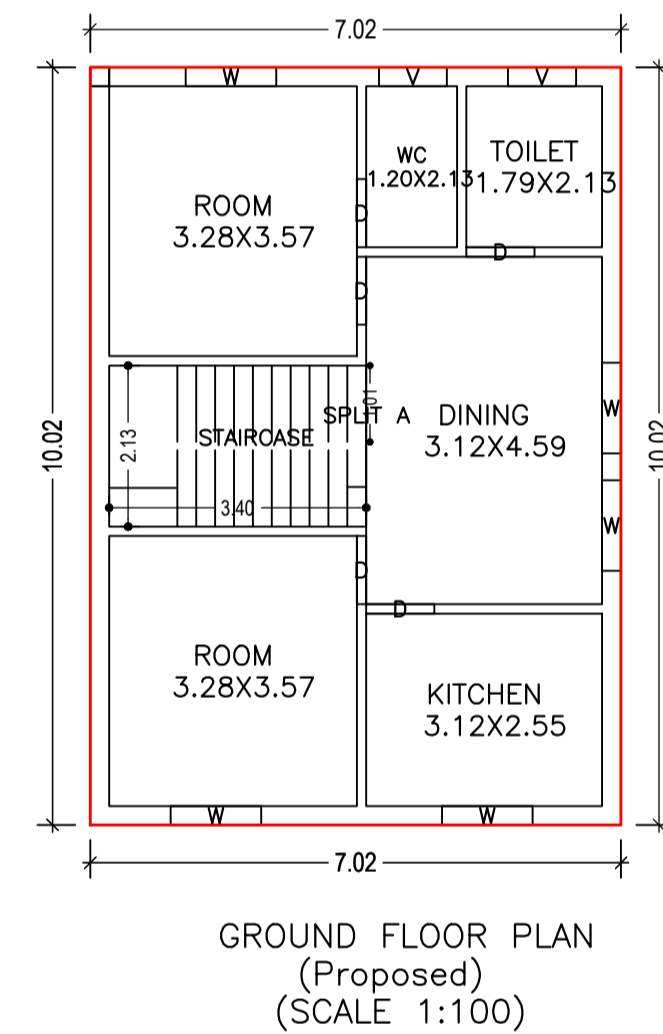
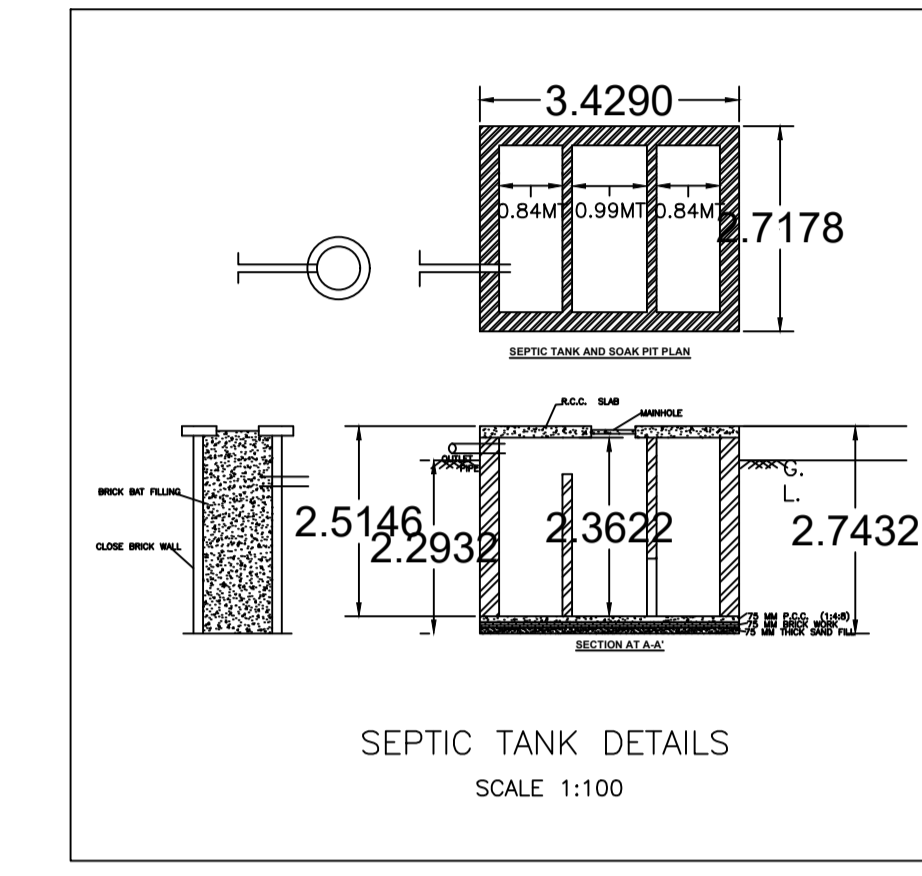
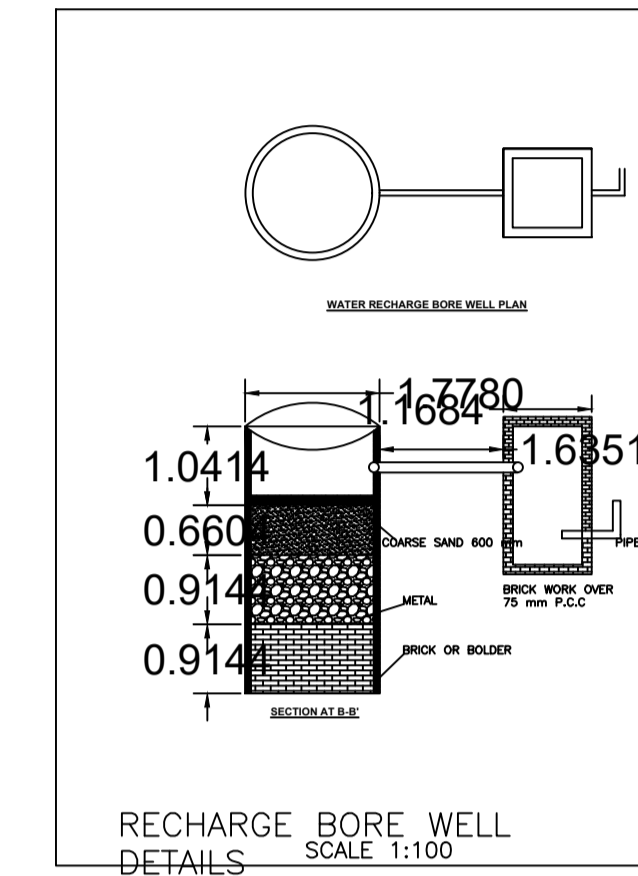
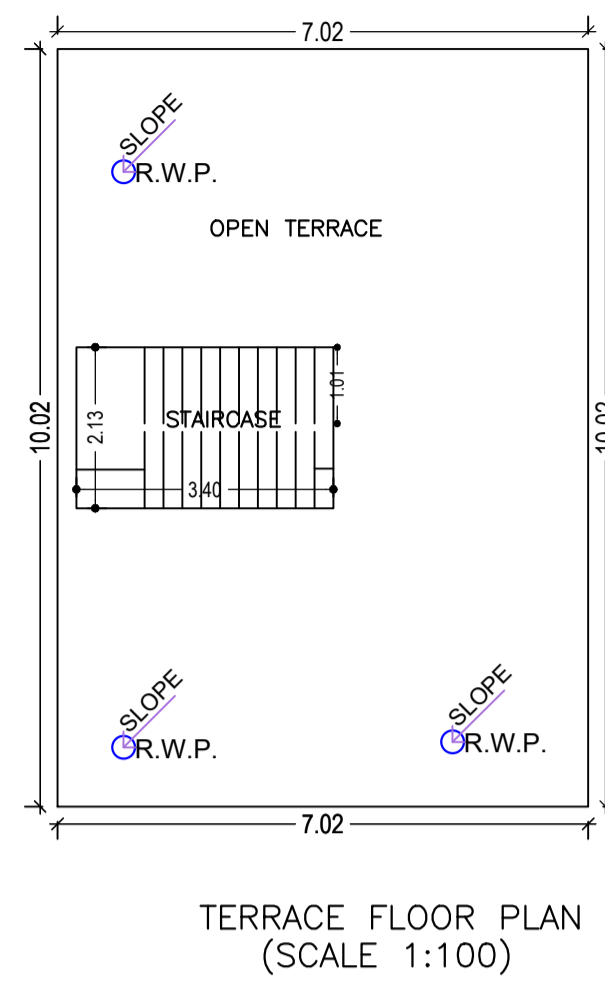
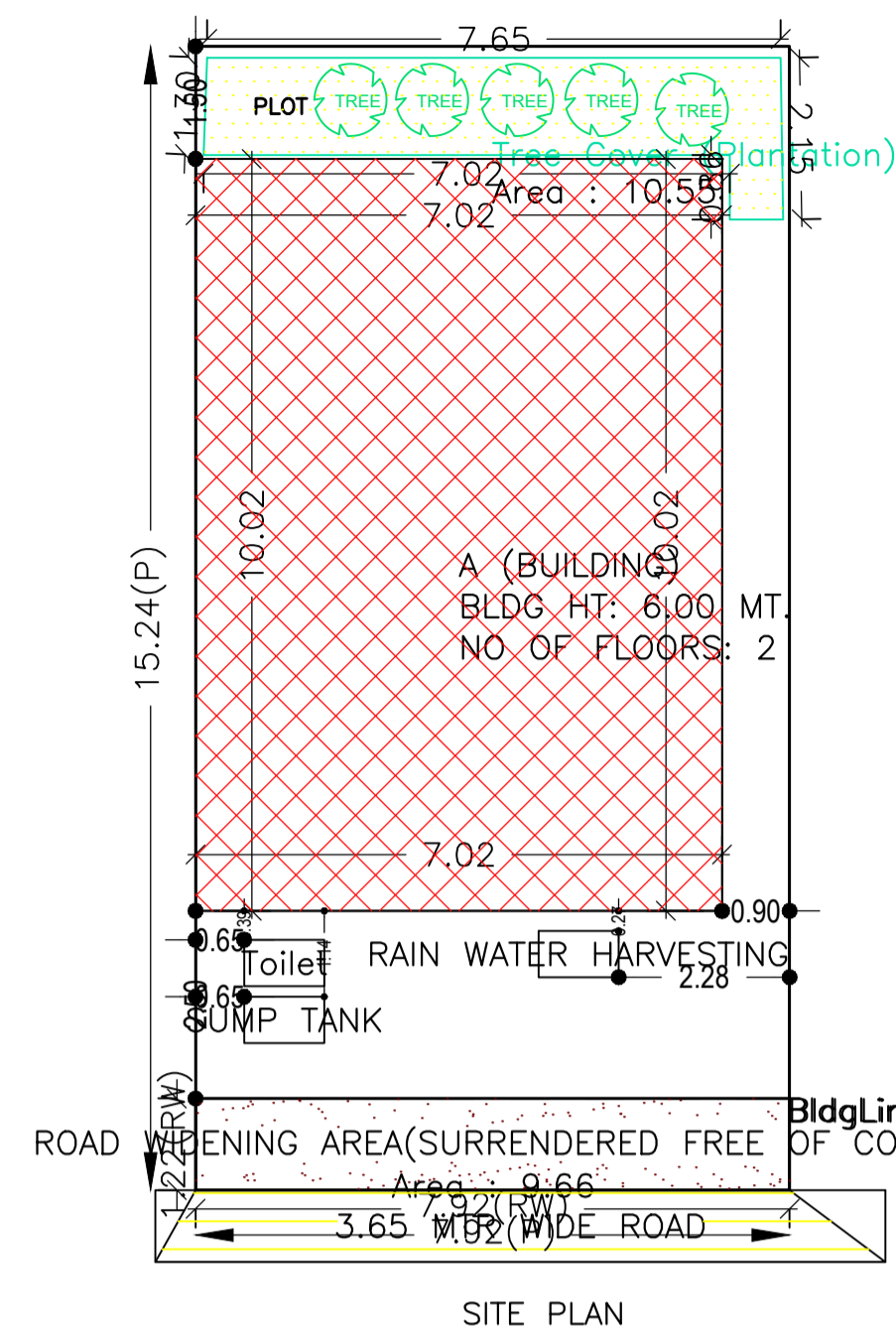

AREA STATEMENT		VERSION NO. : 1.0.68
MEDINAGAR MUNICIPAL CORPORATION		VERSION DATE: 16/10/2020
PROJECT DETAIL:		
Region : JHARKHAND URBAN	Plot Use: Residential	
Local Bodies : PALANJU	Plot SubUse: Bungalow Dwelling / Non Apartment	
District : PALANJU	Plot/Nearby/Religious Structure: NA	
Authority: MEDINAGAR MUNICIPAL CORPORATION	Plot/SubPlot No: 13	
Inward No: MNNP/BP/0051/W03/2024	North: -	
Application Type: General Proposal	South: -	
Project Type: Building Permission	East: -	
Nature of Development: New	West: -	
Location of Development Area: New		
Area		SQ.MT.
AREA OF PLOT (Minimum)	(A)	120.70
Deduction for NetPlot Area		
Surrender Free of Cost		9.66
Total		9.66
NET AREA OF PLOT(Gross Plot Area - Deduction from Gross Plot area)	(A-Deductions)	111.04
Deduction for Balance Plot Area(from Gross Plot Area)		
Surrender Free of Cost		9.66
Common Plot		10.55
Total		20.22
BALANCE AREA OF PLOT(Net Plot Area - Recreational/Amenity space)	(A-Deductions)	100.48
PLOT AREA FOR COVERAGE(Net Plot Area)	(A-Deductions)	111.04
Plot Area for FAR (Net Plot Area + Road Widening Area)	(A-Deductions)	120.70
COVERAGE CHECK		
Permissible Coverage area ( 70.00 % )		77.73
Proposed Coverage Area ( 63.35 % )		70.34
Total Prop. Coverage Area ( 63.35 % )		70.34
Balance coverage area ( 6.66 % )		7.39
FAR CHECK		
Perm. FAR Area ( 1.500 )		181.05
Total Perm. FAR area		181.05
Residential FAR		140.68
Proposed FAR Area		140.68
Total Proposed FAR Area		140.68
Consumed FAR (Factor)		1.17
Balance FAR Area		40.37
BUILT UP AREA CHECK		
Total Proposed BuiltUp Area		140.68
ARCHITECT (Regd)		PANKAJ KUMAR SINGH
ENGINEER (Regd)		
SUPERVISOR (Regd)		
OWNER (Regd)		SUNIL KUMAR PATEL
DEVELOPMENT AUTHORITY		LOCAL BODY

COLOR INDEX	
PLOT BOUNDARY	Black
ABUTTING ROAD	Red
PROPOSED CONSTRUCTION	Green
COMMON PLOT	Yellow
ROAD WIDENING AREA	Blue
EXISTING (To be retained)	Orange
EXISTING (To be demolished)	Grey

Buildingwise Floor FAR Details

Floor Name	Building Name A (BUILDING)		Total	
	Proposed Built Up Area (Sq.mt.)	Proposed FAR Area (Sq.mt.)	Total Proposed Built Up Area (Sq.mt.)	Total FAR Area (Sq.mt.)
Ground Floor	70.34	70.34	70.34	70.34
First Floor	70.34	70.34	70.34	70.34
Terrace Floor	0.00	0.00	0.00	0.00
Total :	140.68	140.68	140.68	140.68

Building USE/SUBUSE Details

Building Name	Building Use	Building SubUse	Building Structure
A (BUILDING)	Residential	Bungalow Dwelling / Non Apartment	Non-Highrise

Floor Name	Total Built Up Area (Sq.mt.)	Proposed FAR Area (Sq.mt.) Resi.	Total FAR Area (Sq.mt.)	Total Consumed Additional FAR Area (Sq.mt.)	Tnmt (No.)
Ground Floor	70.34	70.34	70.34	70.34	01
First Floor	70.34	70.34	70.34	70.34	00
Terrace Floor	0.00	0.00	0.00	0.00	00
Total :	140.68	140.68	140.68	140.68	01
Total Number of Same Buildings :	1				
Total :	140.68	140.68	140.68	140.68	01

SCHEDULE OF DOOR:

BUILDING NAME	NAME	LENGTH	HEIGHT	NOS
A (BUILDING)	D	0.90	2.10	10

SCHEDULE OF WINDOW/VENTILATION:

BUILDING NAME	NAME	LENGTH	HEIGHT	NOS
A (BUILDING)	V	0.90	0.60	04
A (BUILDING)	W	1.20	1.20	10

UnitBUA Table for Building :A (BUILDING)

FLOOR	Name	UnitBUA Type	UnitBUA Area	Carpet Area	No. of Rooms	No. of Tenement
GROUND FLOOR PLAN	SPLIT A	FLAT	125.13	125.01	6	1
FIRST FLOOR PLAN	SPLIT A	FLAT	0.00	0.00	6	0
Total:	-	-	125.13	125.01	12	1

LTP NAME AND SIGNATURE	STRUCTURAL ENG'S NAME AND SIGNATURE	BUILDER NAME AND SIGNATURE	DIGITAL SIGNATURE
PANKAJ KUMAR SINGH MNNP/ENG/006/2019			