

Proposal Basic Information

Proposal File No.	MNNP/BP/0042/W19/2024
Owner Name	Mahendra Prasad
Khata No	112
Plot No	2148
Village Name	Redma
Use	Residential
SubUse	Bungalow Dwelling / Non Apartment

FAR & Tenement Details (Table 4c-1)

Building	No. of Same Bldg	Total Built Up Area (Sq.mt.)	Proposed FAR Area (Sq.mt.) Resi.	Total FAR Area (Sq.mt.)	Total Consumed Additional FAR Area (Sq.mt.)	Tnmt (No.)
A (RESIDENTIAL)	1	50.55	50.55	50.55	50.55	01
Grand Total :	1	50.55	50.55	50.55	50.55	01

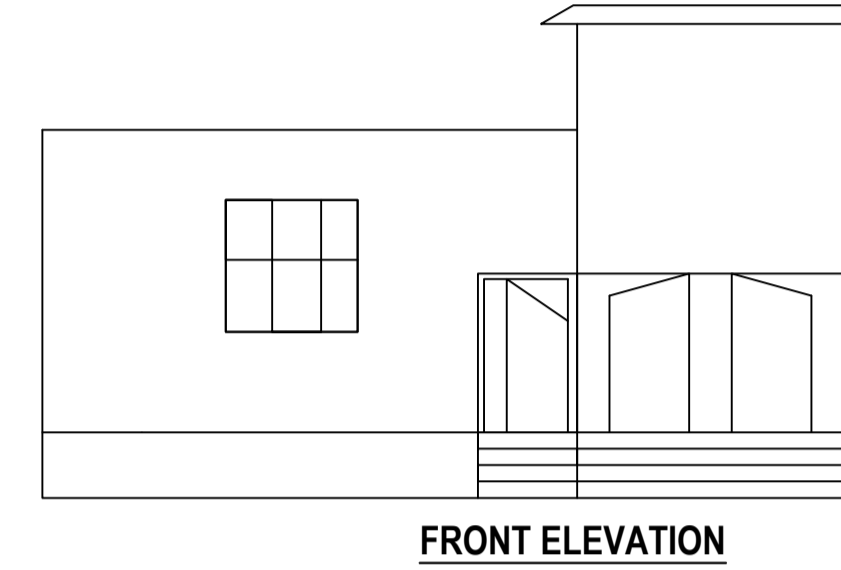
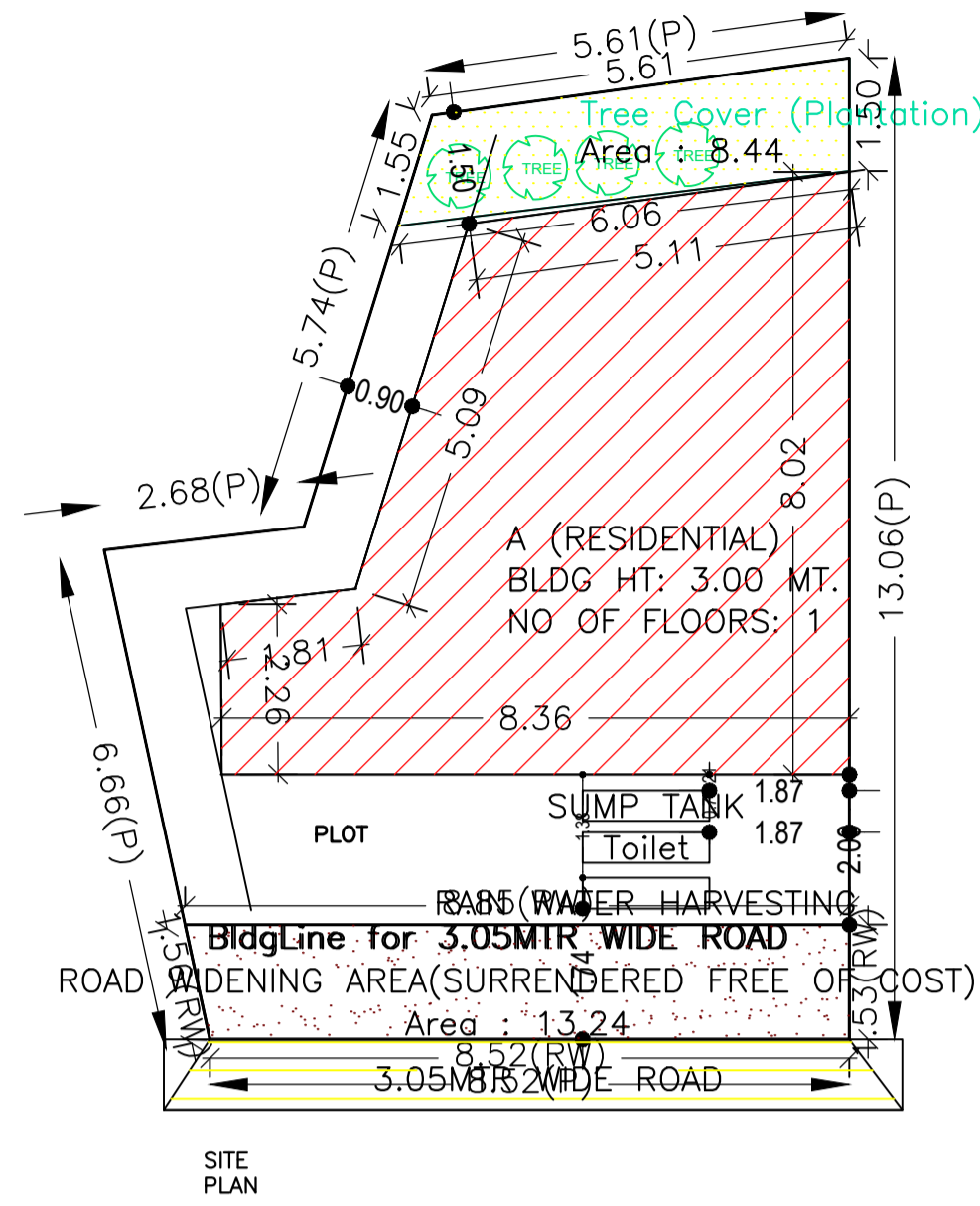

FRONT ELEVATION

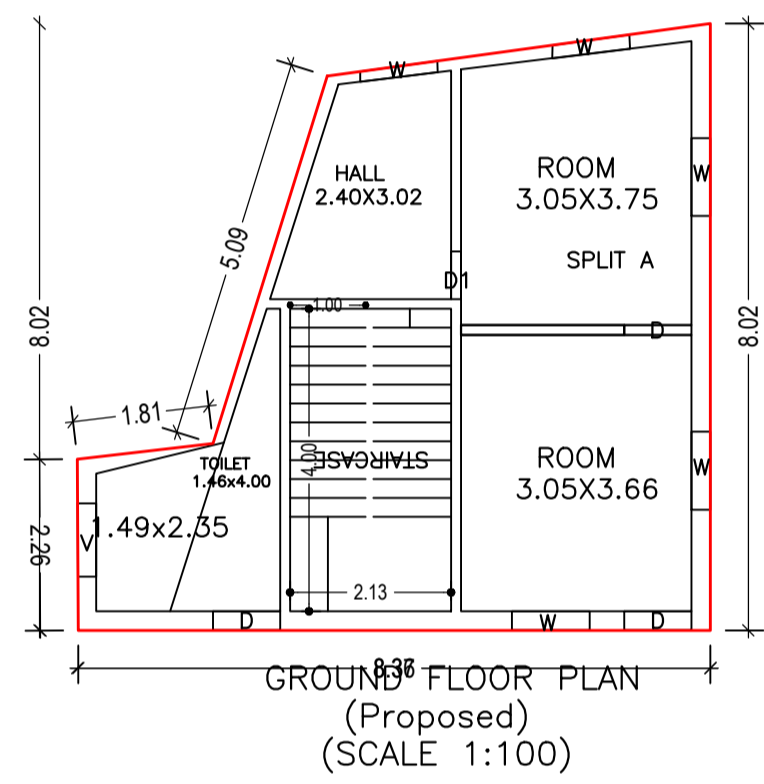

GROUND FLOOR PLAN (Proposed) (SCALE 1:100)

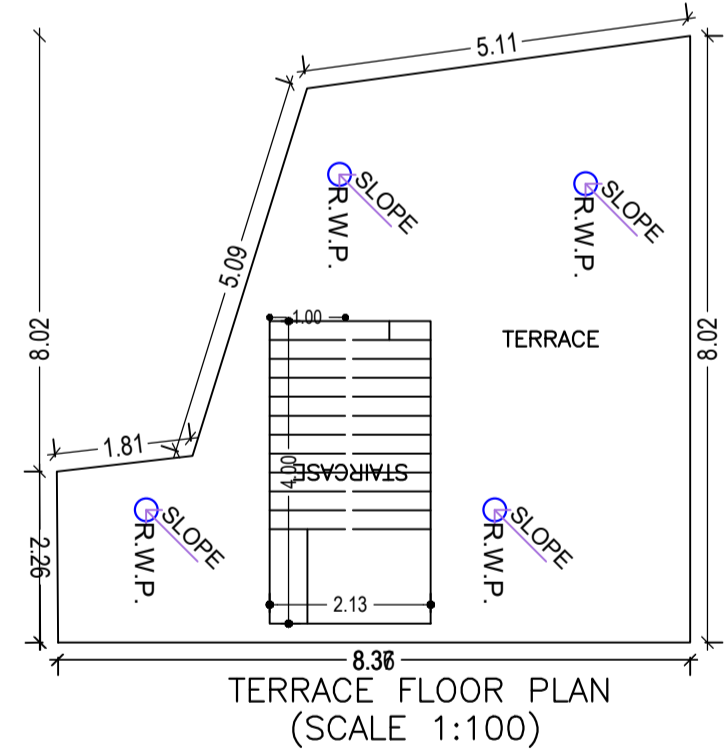

TERRACE FLOOR PLAN (SCALE 1:100)

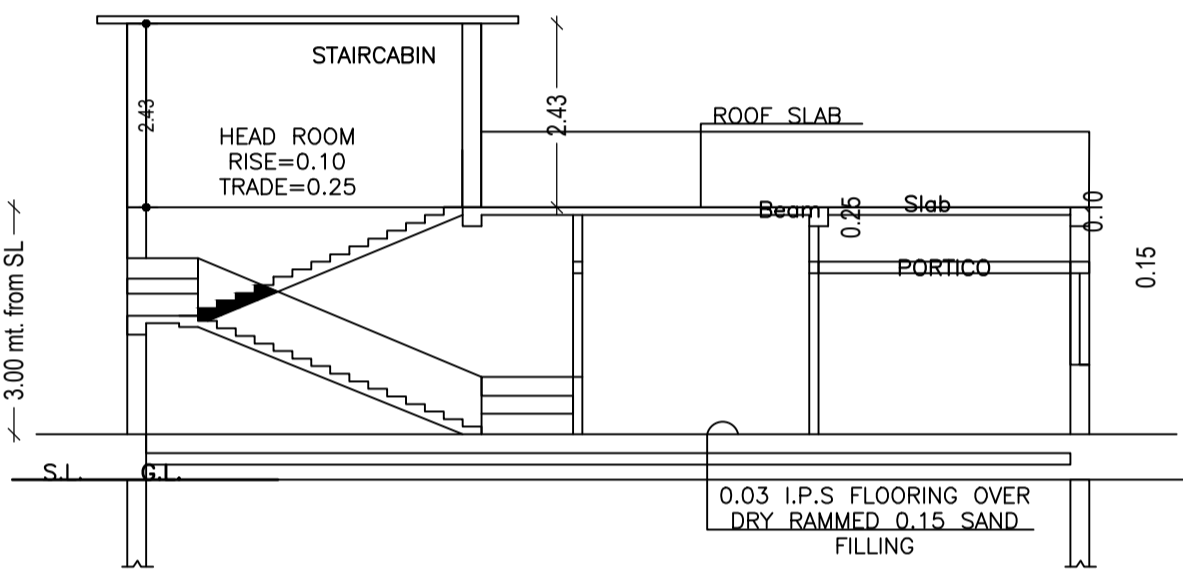

SECTION ON-XX

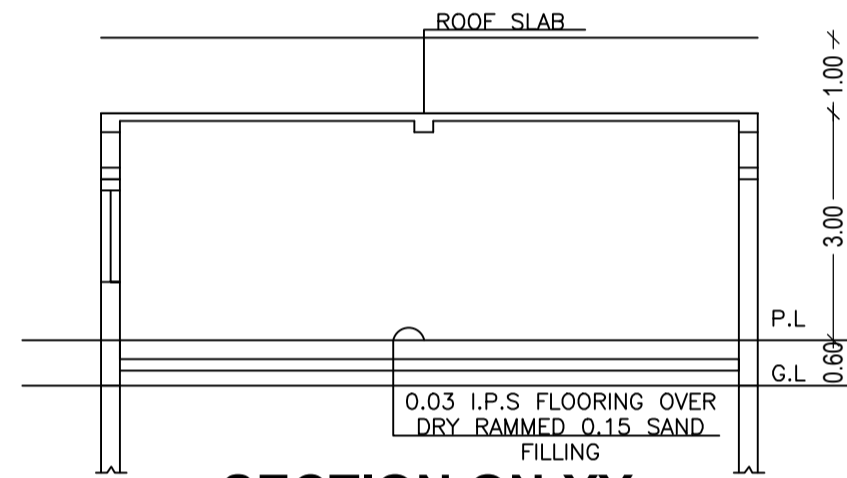

SECTION ON-YY

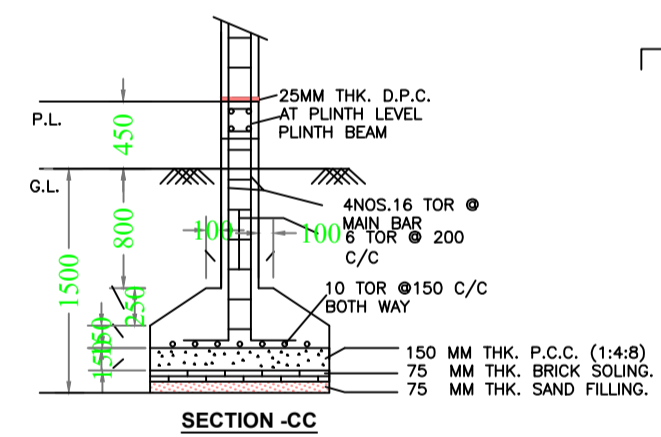

STRUCTURAL DETAIL

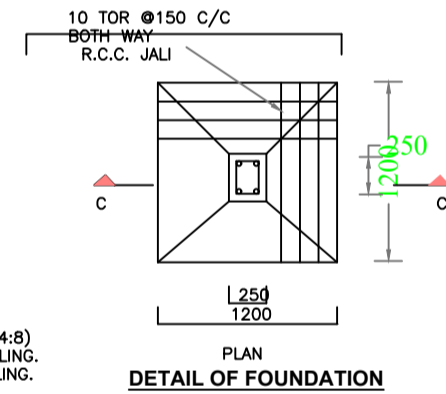

DETAIL OF FOUNDATION

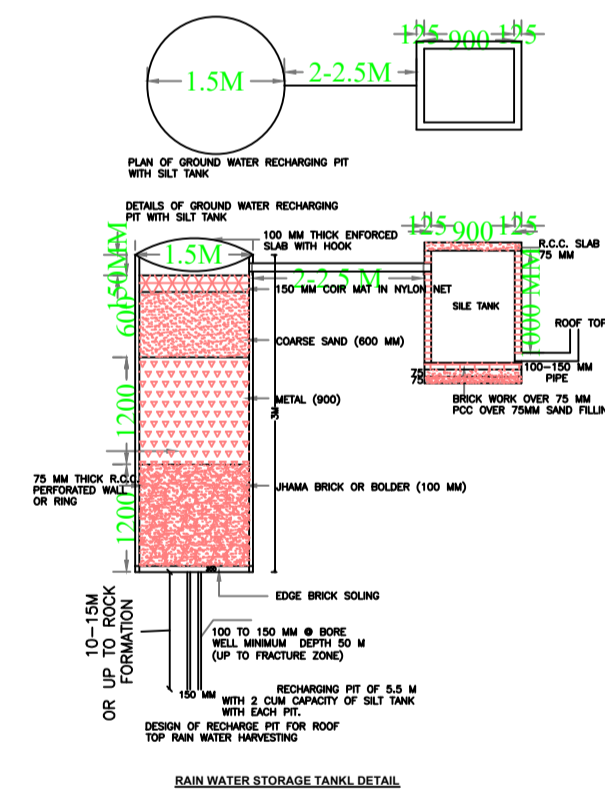

RAIN WATER STORAGE TANK DETAIL

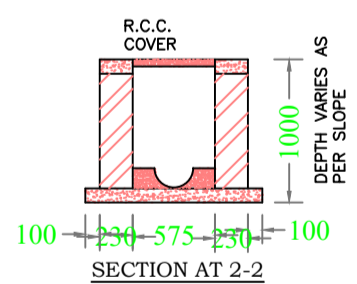

SECTION AT 2-2

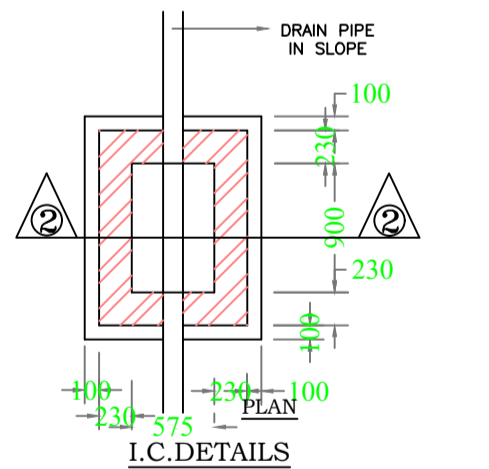

L.C. DETAILS

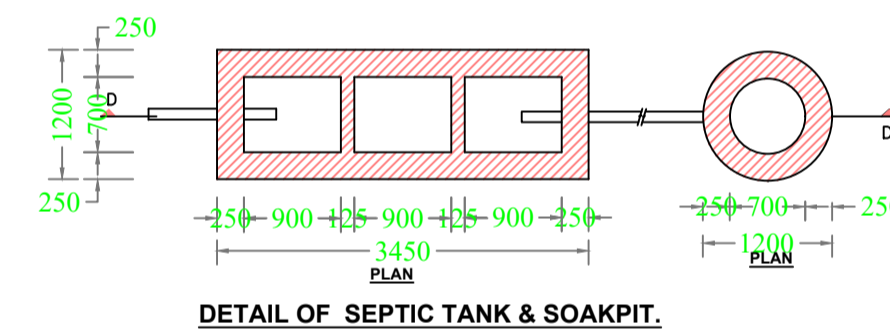

DETAIL OF SEPTIC TANK & SOAKPIT.

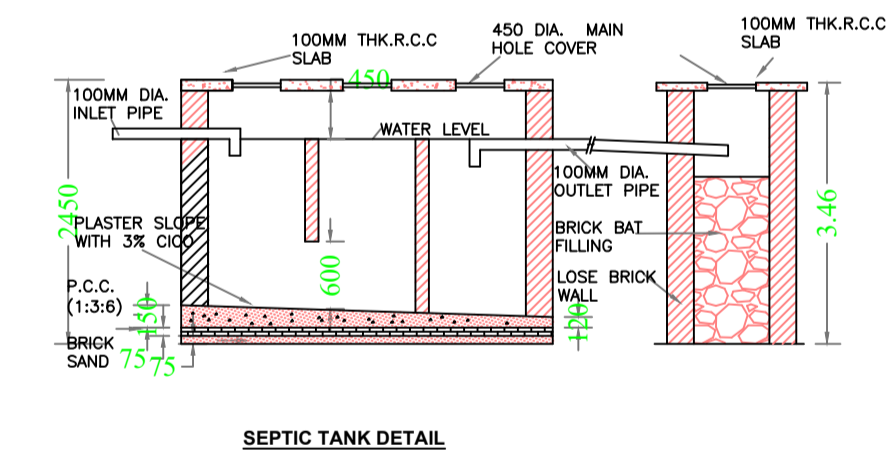

SEPTIC TANK DETAIL

AREA STATEMENT	VERSION NO. : 1.0.68
MEDINAGAR MUNICIPAL CORPORATION	VERSION DATE: 16/10/2020
PROJECT DETAIL:	
Region : JHARKHAND URBAN LOCAL BODIES	Plot Use: Residential
District: PALAMU	Plot SubUse: Bungalow Dwelling / Non Apartment
Authority: MEDINAGAR MUNICIPAL CORPORATION	Plot/Nearby/Religious/Structure: NA
Inward No: MNNP/BP/0042/W19/2024	Plot/SubPlot No: 2148
Application Type: General Proposal	North: -
Project Type: Building Permission	South: -
Nature of Development: New	East: -
Location of Development Area: New	West: -
AREA DETAILS:	SQ.MT.
AREA OF PLOT (Minimum)	(A) 99.99
Deduction for NetPlot Area	
Surrender Free of Cost	13.24
Total	13.24
NET AREA OF PLOT(Gross Plot Area - Deduction from Gross Plot area)	(A-Deductions) 86.75
Deduction for Balance Plot Area(from Gross Plot Area)	
Surrender Free of Cost	13.24
Common Plot	8.44
Total	21.68
BALANCE AREA OF PLOT(Net Plot Area - Recreational/Amenity space)	(A-Deductions) 78.31
PLOT AREA FOR COVERAGE(Net Plot Area)	(A-Deductions) 86.75
Plot Area for FAR (Net Plot Area + Road Widening Area)	(A-Deductions) 99.99
COVERAGE CHECK	
Permissible Coverage area (70.00 %)	60.72
Proposed Coverage Area (58.27 %)	50.55
Total Prop. Coverage Area (58.27 %)	50.55
Balance coverage area (11.72 %)	10.17
FAR CHECK	
Perm. FAR Area (1.200)	119.99
Total Perm. FAR area	119.99
Residential FAR	50.55
Proposed FAR Area	50.55
Total Proposed FAR Area	50.55
Consumed FAR (Factor)	0.51
Balance FAR Area	69.44
BUILT UP AREA CHECK	
Total Proposed BuiltUp Area	50.55
ARCHITECT (Regd)	RANJIT KUMAR
ENGINEER (Regd)	
SUPERVISOR (Regd)	
OWNER (Regd)	Mahendra Prasad
DEVELOPMENT AUTHORITY	LOCAL BODY

COLOR INDEX	
PLOT BOUNDARY	
ABUTTING ROAD	
PROPOSED CONSTRUCTION	
COMMON PLOT	
ROAD WIDENING AREA	
EXISTING (To be retained)	
EXISTING (To be demolished)	

Buildingwise Floor FAR Details

Floor Name	Building Name A (RESIDENTIAL)		Total	
	Proposed Built Up Area (Sq.mt.)	Proposed FAR Area (Sq.mt.)	Total Proposed Built Up Area (Sq.mt.)	Total FAR Area (Sq.mt.)
Ground Floor	50.55	50.55	50.55	50.55
Terrace Floor	0.00	0.00	0.00	0.00
Total :	50.55	50.55	50.55	50.55

Building USE/SUBUSE Details

Building Name	Building Use	Building SubUse	Building Structure
A (RESIDENTIAL)	Residential	Bungalow Dwelling / Non Apartment	Non-Highrise

Building :A (RESIDENTIAL)

Floor Name	Total Built Up Area (Sq.mt.)	Proposed FAR Area (Sq.mt.) Resi.	Total FAR Area (Sq.mt.)	Total Consumed Additional FAR Area (Sq.mt.)	Tnmt (No.)
Ground Floor	50.55	50.55	50.55	50.55	01
Terrace Floor	0.00	0.00	0.00	0.00	00
Total :	50.55	50.55	50.55	50.55	01
Total Number of Same Buildings	1				
Total :	50.55	50.55	50.55	50.55	01

SCHEDULE OF DOOR:

BUILDING NAME	NAME	LENGTH	HEIGHT	NOS
A (RESIDENTIAL)	D1	0.63	2.10	01
A (RESIDENTIAL)	D	0.89	2.10	03

SCHEDULE OF WINDOW/VENTILATION:

BUILDING NAME	NAME	LENGTH	HEIGHT	NOS
A (RESIDENTIAL)	V	0.97	0.60	01
A (RESIDENTIAL)	W	1.03	1.20	04
A (RESIDENTIAL)	W	1.04	1.20	01

UnitBUA Table for Building :A (RESIDENTIAL)

FLOOR	Name	UnitBUA Type	UnitBUA Area	Carpet Area	No. of Rooms	No. of Tenement
GROUND FLOOR PLAN	SPLIT A	FLAT	41.49	41.21	4	1
Total:	-	-	41.49	41.21	4	1

LTP NAME AND SIGNATURE	STRUCTURAL ENG'S NAME AND SIGNATURE	BUILDER NAME AND SIGNATURE	DIGITAL SIGNATURE
RANJIT KUMAR MNNP/ENG/0001/2016			