

SITE PLAN

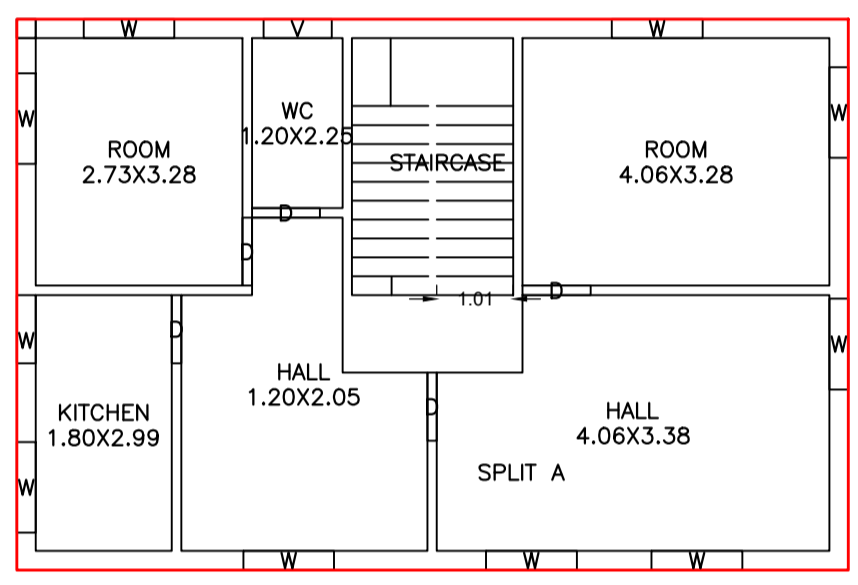

GROUND FLOOR PLAN (Proposed) (SCALE 1:100)

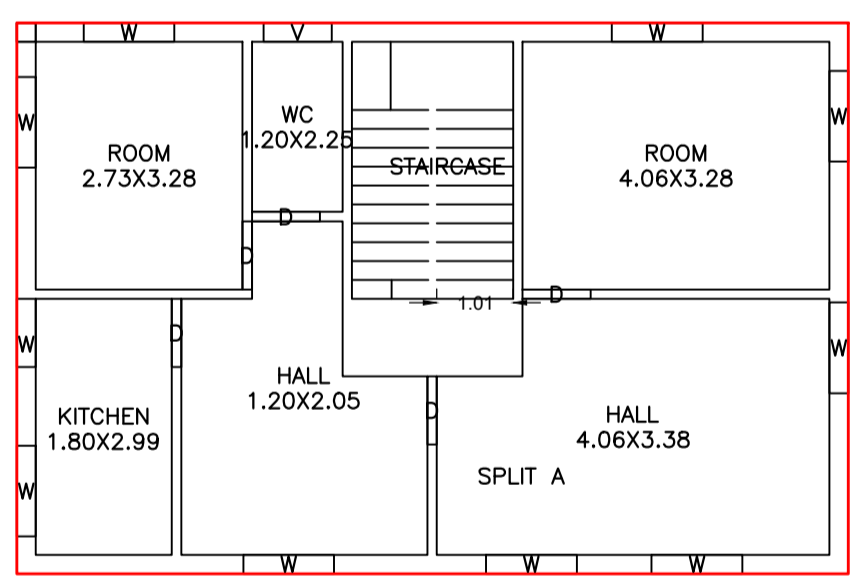

TYPICAL -1&2 FLOOR PLAN (Proposed) (SCALE 1:100)

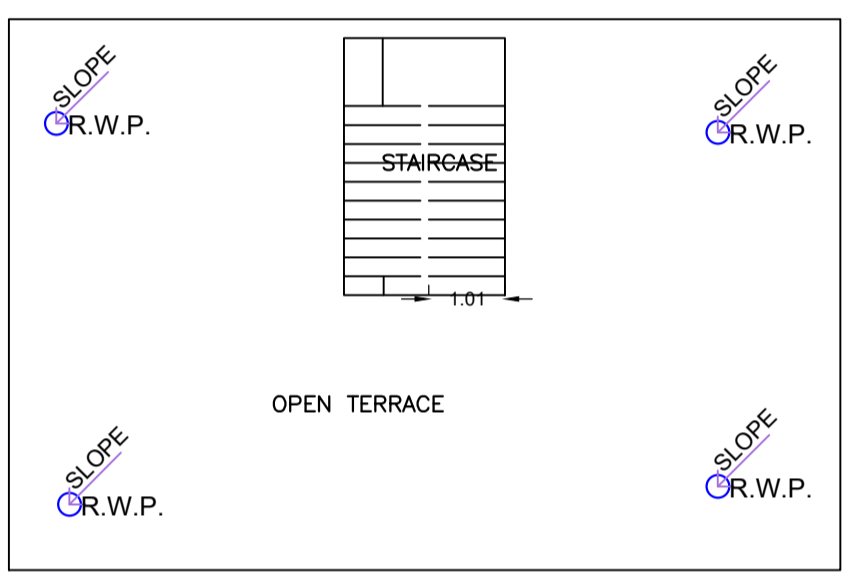

TERRACE FLOOR PLAN (SCALE 1:100)

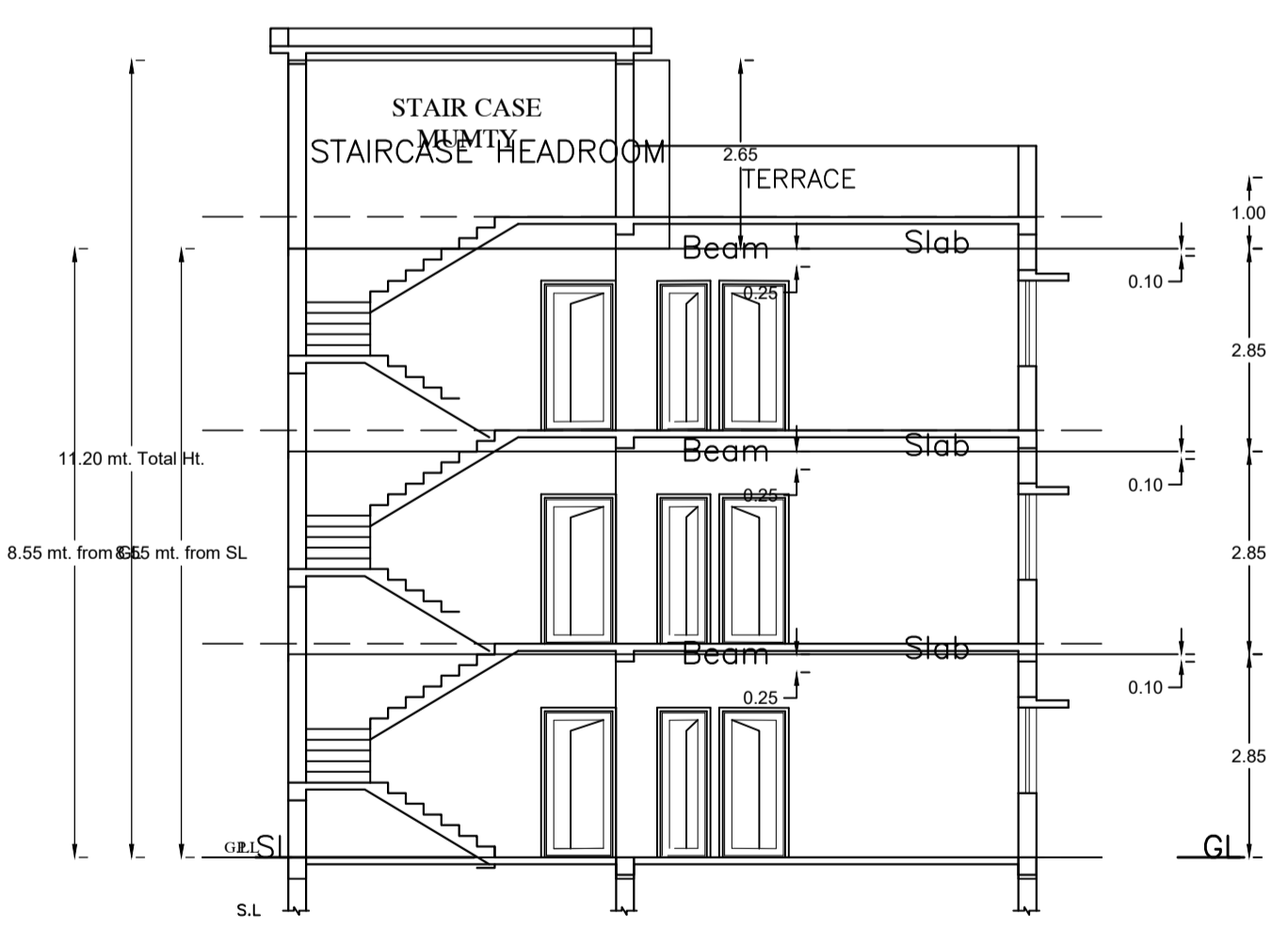

SECTION X-X Scale 1:100

Building :A (BUILDING)

Floor Name	Total Built Up Area (Sq.mt.)	Proposed FAR Area (Sq.mt.) Resi.	Total FAR Area (Sq.mt.)	Total Consumed Additional FAR Area (Sq.mt.)	Tnmt (No.)
Ground Floor	80.13	80.13	80.13	80.13	01
First Floor	80.13	80.13	80.13	80.13	00
Second Floor	80.13	80.13	80.13	80.13	00
Terrace Floor	0.00	0.00	0.00	0.00	00
Total :	240.39	240.39	240.39	240.39	01
Total Number of Same Buildings	1				
Total :	240.39	240.39	240.39	240.39	01

SCHEDULE OF DOOR:

BUILDING NAME	NAME	LENGTH	HEIGHT	NOS
A (BUILDING)	D	0.90	2.10	15

SCHEDULE OF WINDOW/VENTILATION:

BUILDING NAME	NAME	LENGTH	HEIGHT	NOS
A (BUILDING)	V	0.90	0.60	03
A (BUILDING)	W	0.90	1.20	03
A (BUILDING)	W	1.20	1.20	27



RIGHT SIDE ELEVATION Scale 1:100

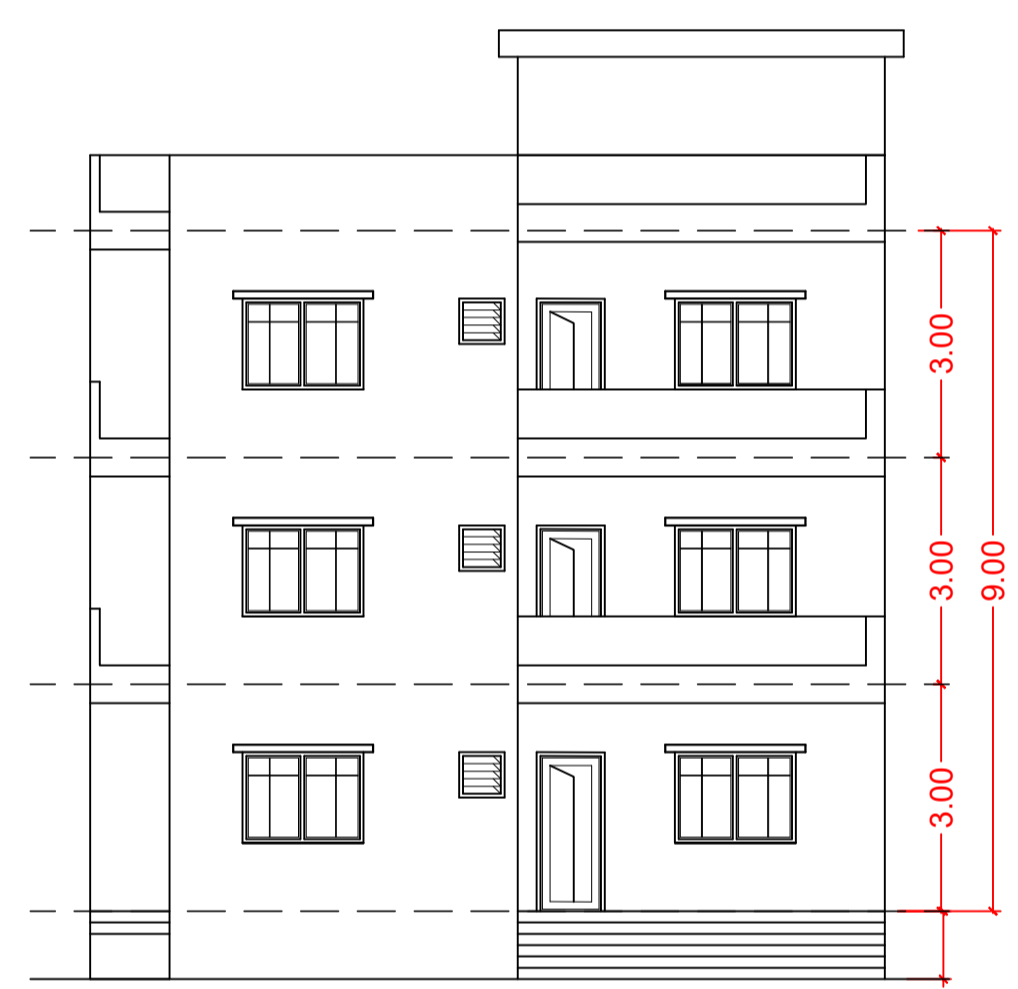

FRONT ELEVATION Scale 1:100

FAR & Tenement Details (Table 4c-1)

Building	No. of Same Bldg	Total Built Up Area (Sq.mt.)	Proposed FAR Area (Sq.mt.) Resi.	Total FAR Area (Sq.mt.)	Total Consumed Additional FAR Area (Sq.mt.)	Tnmt (No.)
A (BUILDING)	1	240.39	240.39	240.39	240.39	01
Grand Total :	1	240.39	240.39	240.39	240.39	01

Proposal Basic Information

Proposal File No.	MNNP/BP/0058/W03/2024
Owner Name	RADHIKA KUMARI
Khata No	32
Plot No	51
Village Name	Nimiya
Use	Residential
SubUse	Bungalow/ Dwelling / Non Apartment

AREA STATEMENT	VERSION NO. : 1.0.69
MEDININAGAR MUNICIPAL CORPORATION	VERSION DATE: 16/10/2020
PROJECT DETAIL:	
Region: JHARKHAND URBAN LOCAL BODIES	Plot Use: Residential
District: PALAMU	Plot SubUse: Bungalow/ Dwelling / Non Apartment
Authority: MEDININAGAR MUNICIPAL CORPORATION	PlotNearbyReligiousStructure: NA
Inward No: MNNP/BP/0058/W03/2024	Plot/SubPlot No: 51
Application Type: General Proposal	North: -
Project Type: Building Permission	South: -
Nature of Development: New	East: -
Location of Development Area: New Area	West: -
AREA DETAILS:	SQ.MT.
AREA OF PLOT (Minimum)	(A) 161.79
Deduction for NetPlot Area	
Surrender Free of Cost	15.62
Total	15.62
NET AREA OF PLOT (Gross Plot Area - Deduction from Gross Plot area)	(A-Deductions) 146.18
Deduction for Balance Plot Area (from Gross Plot Area)	
Surrender Free of Cost	15.62
Common Plot	17.25
Total	32.87
BALANCE AREA OF PLOT (Net Plot Area - Recreational/Amenity space)	(A-Deductions) 128.93
PLOT AREA FOR COVERAGE (Net Plot Area)	(A-Deductions) 146.18
Plot Area for FAR (Net Plot Area + Road/Widening Area)	(A-Deductions) 161.79
COVERAGE CHECK	
Permissible Coverage area (70.00 %)	102.33
Proposed Coverage Area (54.82 %)	80.13
Total Prop. Coverage Area (54.82 %)	80.13
Balance coverage area (15.19 %)	22.20
FAR CHECK	
Perm. FAR Area (1.500)	242.68
Total Perm. FAR area	242.68
Residential FAR	240.40
Proposed FAR Area	240.40
Total Proposed FAR Area	240.40
Consumed FAR (Factor)	1.49
Balance FAR Area	2.28
BUILT UP AREA CHECK	
Total Proposed BuiltUp Area	240.39
ARCHITECT (Regd)	PANKAJ KUMAR SINGH
ENGINEER (Regd)	
SUPERVISOR (Regd)	
OWNER (Regd)	RADHIKA KUMARI
DEVELOPMENT AUTHORITY	LOCAL BODY

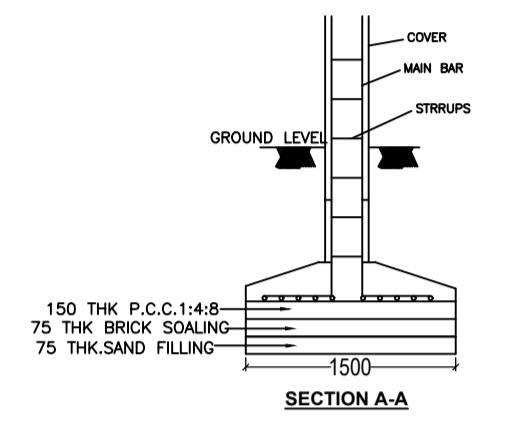

DETAIL OF FOUNDATION SCALE = N.T.S.

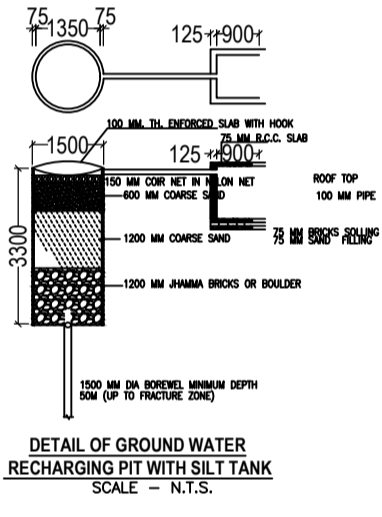

DETAIL OF GROUND WATER RECHARGING PIT WITH SUMP TANK SCALE = N.T.S.

COLOR INDEX

PLOT BOUNDARY	[Red Line]
ABUTTING ROAD	[Green Line]
PROPOSED CONSTRUCTION	[Yellow Line]
COMMON PLOT	[Blue Line]
ROAD WIDENING AREA	[Orange Line]
EXISTING (To be retained)	[Grey Line]
EXISTING (To be demolished)	[Black Line]

Buildingwise Floor FAR Details

Floor Name	Building Name A (BUILDING)		Total	
	Proposed Built Up Area (Sq.mt.)	Proposed FAR Area (Sq.mt.)	Total Proposed Built Up Area (Sq.mt.)	Total FAR Area (Sq.mt.)
Ground Floor	80.13	80.13	80.13	80.13
First Floor	80.13	80.13	80.13	80.13
Second Floor	80.13	80.13	80.13	80.13
Terrace Floor	0.00	0.00	0.00	0.00
Total :	240.39	240.39	240.39	240.39

Building USE/SUBUSE Details

Building Name	Building Use	Building SubUse	Building Structure
A (BUILDING)	Residential	Bungalow/ Dwelling / Non Apartment	Non-Highrise

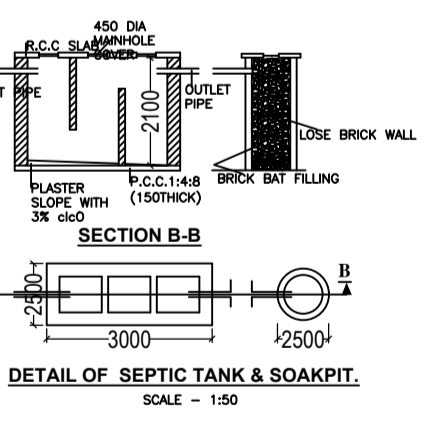

DETAIL OF SEPTIC TANK & SOAKPIT SCALE = 1:50

LTP NAME AND SIGNATURE	STRUCTURAL ENG'S NAME AND SIGNATURE	BUILDER NAME AND SIGNATURE	DIGITAL SIGNATURE
PANKAJ KUMAR SINGH MNNP/ENG/0006/2019			