

Proposal Basic Information

Proposal File No.	MNNP/BP/0014/W34/2024
Owner Name	PUSHPA DEVI
Khata No	07
Plot No	151/220
Village Name	Chainpur
Use	Residential
SubUse	Bungalow Dwelling / Non Apartment

FAR & Tenement Details (Table 4c-1)

Building	No. of Same Bldg	Total Built Up Area (Sq.mt.)	Proposed FAR Area (Sq.mt.) Resi.	Total FAR Area (Sq.mt.)	Total Consumed Additional FAR Area (Sq.mt.)	Tnmt (No.)
A (RESIDENTIAL)	1	50.76	50.76	50.76	50.76	01
Grand Total :	1	50.76	50.76	50.76	50.76	01

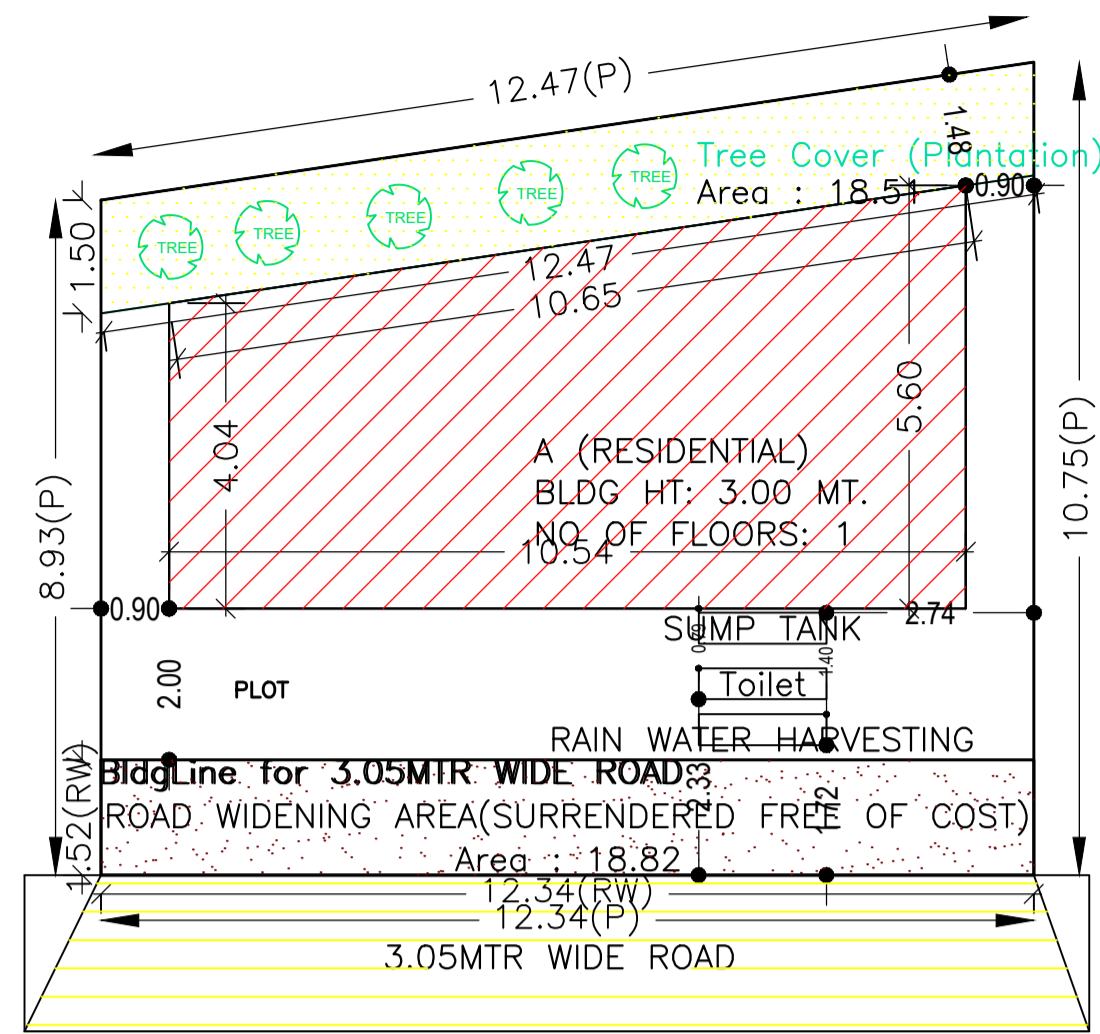

SITE PLAN

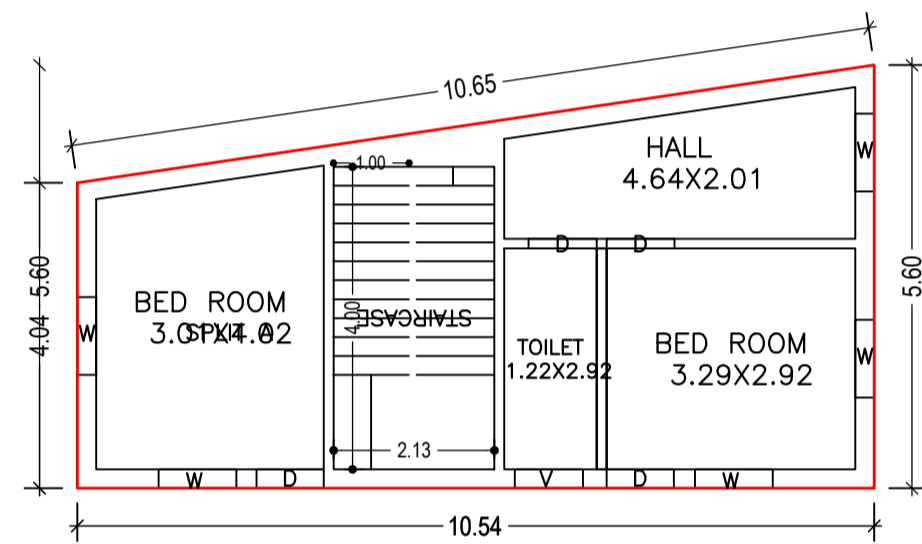

GROUND FLOOR PLAN (Proposed) (SCALE 1:100)

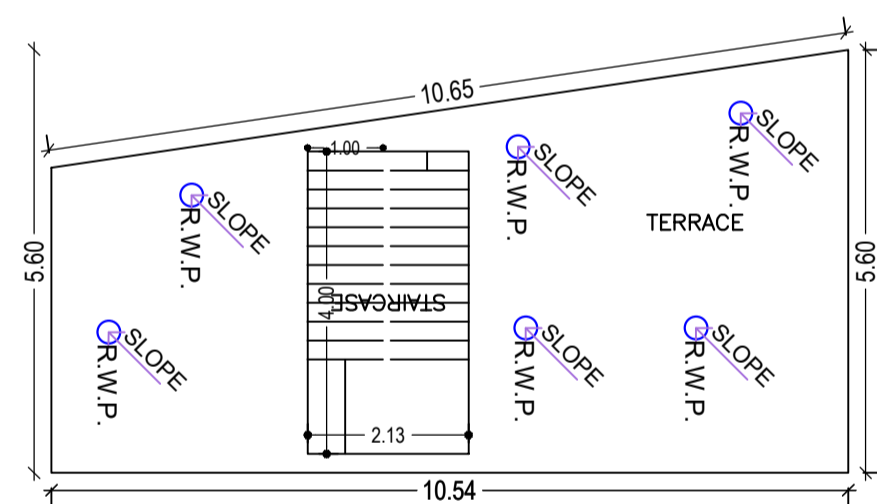

TERRACE FLOOR PLAN (SCALE 1:100)

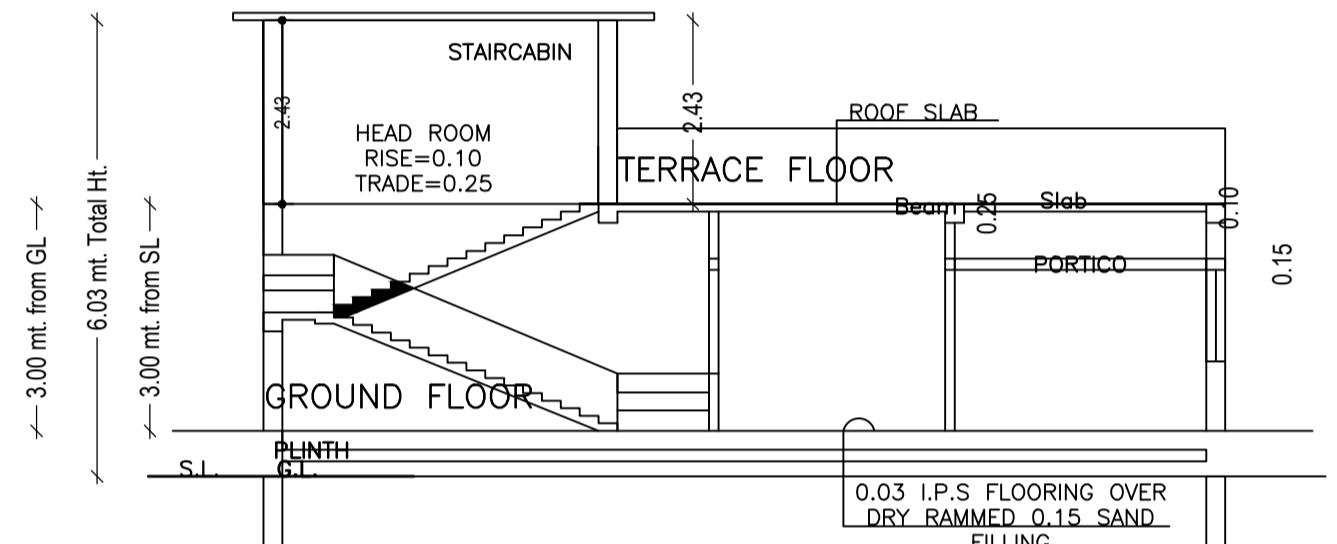

SECTION ON-XX

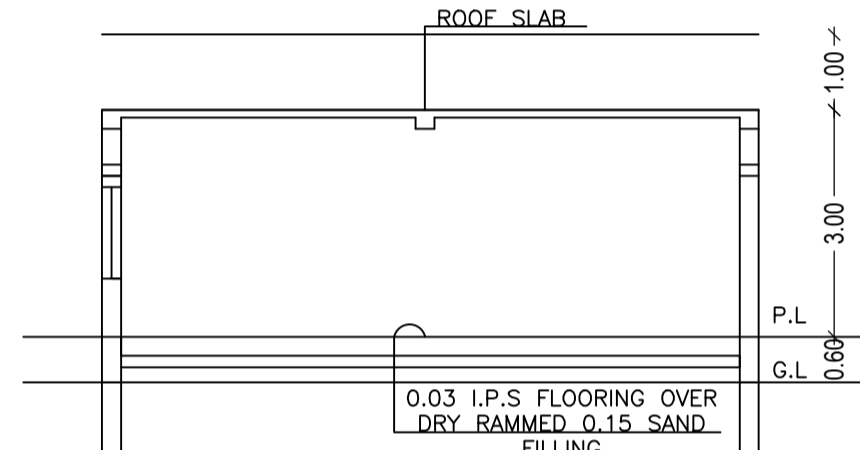

SECTION ON-YY

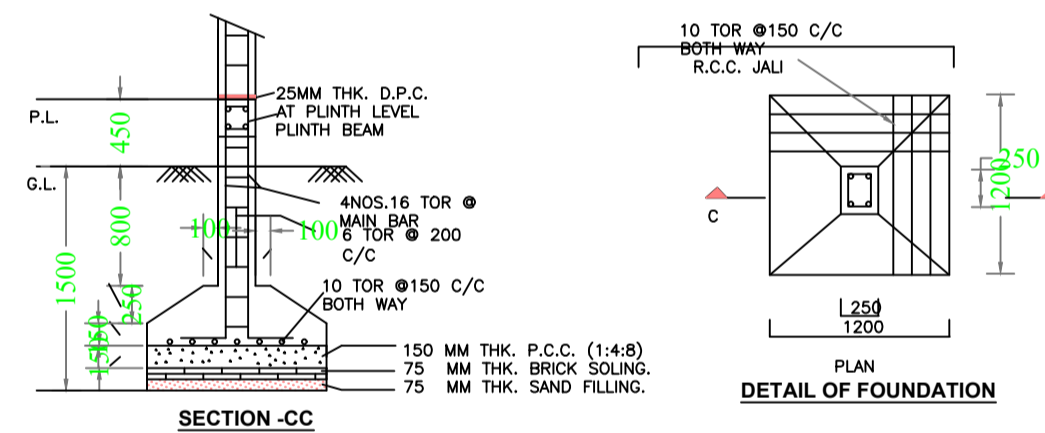

STRUCTURAL DETAIL

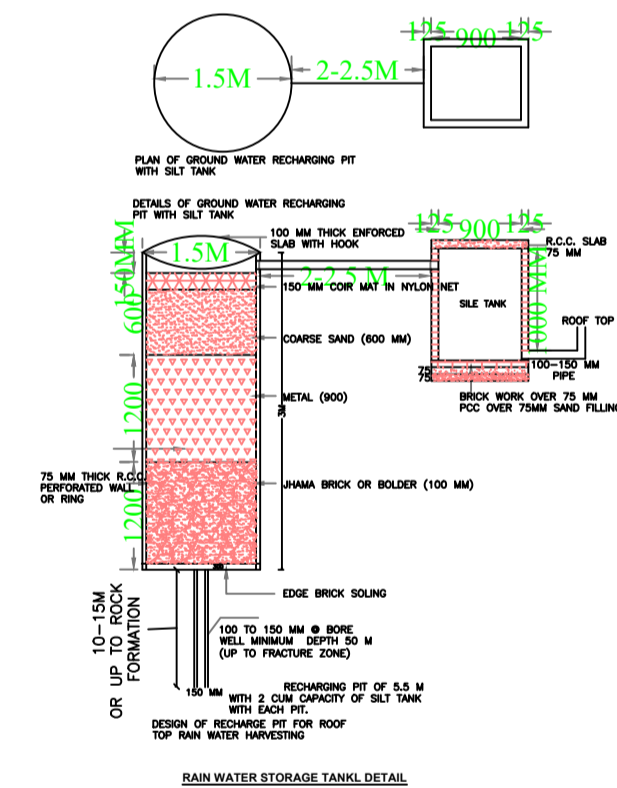

I.C.DETAILS

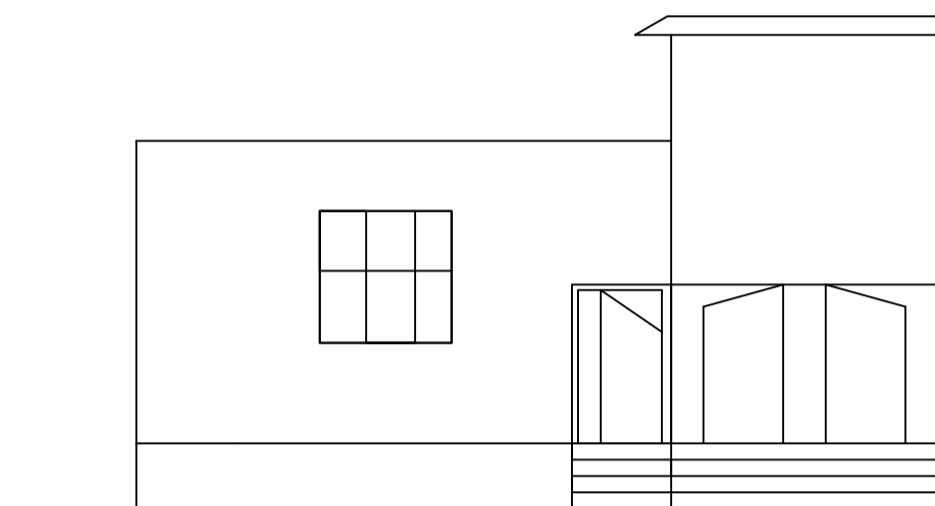

FRONT ELEVATION

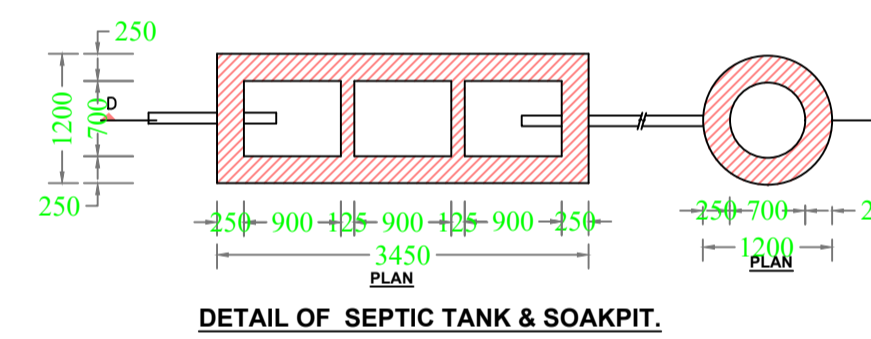
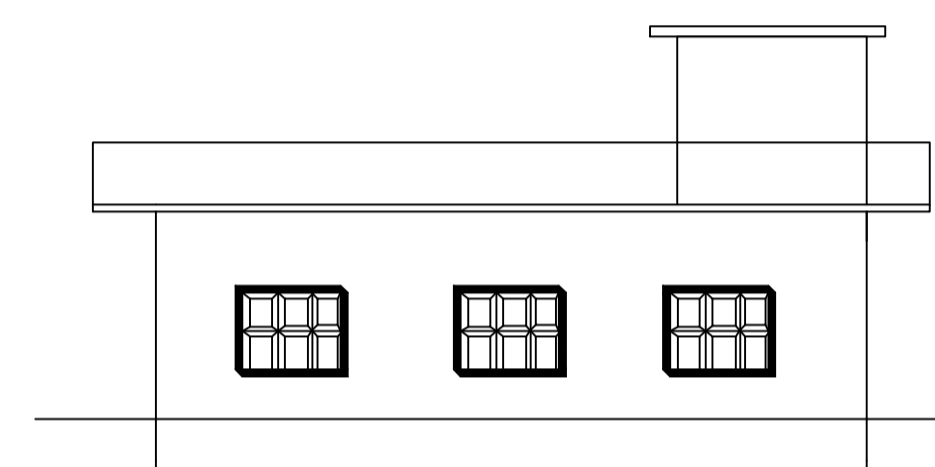

DETAIL OF SEPTIC TANK & SOAKPIT.

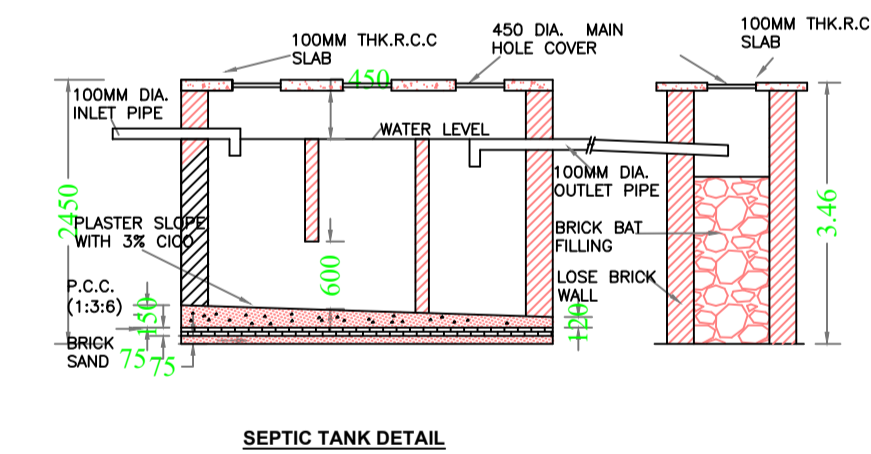

SEPTIC TANK DETAIL

AREA STATEMENT	VERSION NO. : 1.0.68
MEDINAGAR MUNICIPAL CORPORATION	VERSION DATE: 16/10/2020
PROJECT DETAIL:	
Region : JHARKHAND URBAN	Plot Use: Residential
LOCAL BODIES	Plot SubUse: Bungalow/ Dwelling / Non Apartment
District: PALAMU	PlotNearbyReligiousStructure: NA
Authority: MEDINAGAR MUNICIPAL CORPORATION	Plot/SubPlot No: 151/220
Inward No: MNNP/BP/0014/W34/2024	North: -
Application Type: General Proposal	South: -
Project Type: Building Permission	East: -
Nature of Development: New	West: -
Location of Development Area: New	
AREA DETAILS:	SQ.MT.
AREA OF PLOT (Minimum)	(A) 121.44
Deduction for NetPlot Area	
Surrender Free of Cost	18.82
Total	18.82
NET AREA OF PLOT(Gross Plot Area - Deduction for Gross Plot area)	(A-Deductions) 102.62
Deduction for Balance Plot Area(from Gross Plot Area)	
Surrender Free of Cost	18.82
Common Plot	18.51
Total	37.33
BALANCE AREA OF PLOT(Net Plot Area - Recreational/Amenity space)	(A-Deductions) 84.11
PLOT AREA FOR COVERAGE(Net Plot Area)	(A-Deductions) 102.62
Plot Area for FAR (Net Plot Area + RoadWidening Area)	(A-Deductions) 121.44
COVERAGE CHECK	
Permissible Coverage area (70.00 %)	71.83
Proposed Coverage Area (49.46 %)	50.76
Total Prop. Coverage Area (49.46 %)	50.76
Balance coverage area (20.53 %)	21.07
FAR CHECK	
Perm. FAR Area (1.200)	145.73
Total Perm. FAR area	145.73
Residential FAR	50.76
Proposed FAR Area	50.76
Total Proposed FAR Area	50.76
Consumed FAR (Factor)	0.42
Balance FAR Area	94.97
BUILT UP AREA CHECK	
Total Proposed BuiltUp Area	50.76
ARCHITECT (Regd)	RANJIT KUMAR
ENGINEER (Regd)	
SUPERVISOR (Regd)	
OWNER (Regd)	PUSHPA DEVI
DEVELOPMENT AUTHORITY	LOCAL BODY

COLOR INDEX	
PLOT BOUNDARY	[Red Line]
ABUTTING ROAD	[Green Line]
PROPOSED CONSTRUCTION	[Yellow Line]
COMMON PLOT	[Blue Line]
ROAD WIDENING AREA	[Orange Line]
EXISTING (To be retained)	[Grey Line]
EXISTING (To be demolished)	[Black Line]

Buildingwise Floor FAR Details

Floor Name	Building Name A (RESIDENTIAL)		Total	
	Proposed Built Up Area (Sq.mt.)	Proposed FAR Area (Sq.mt.)	Total Proposed Built Up Area (Sq.mt.)	Total FAR Area (Sq.mt.)
Ground Floor	50.76	50.76	50.76	50.76
Terrace Floor	0.00	0.00	0.00	0.00
Total :	50.76	50.76	50.76	50.76

Building USE/SUBUSE Details

Building Name	Building Use	Building SubUse	Building Structure
A (RESIDENTIAL)	Residential	Bungalow Dwelling / Non Apartment	Non-Highrise

Building :A (RESIDENTIAL)

Floor Name	Total Built Up Area (Sq.mt.)	Proposed FAR Area (Sq.mt.) Resi.	Total FAR Area (Sq.mt.)	Total Consumed Additional FAR Area (Sq.mt.)	Tnmt (No.)
Ground Floor	50.76	50.76	50.76	50.76	01
Terrace Floor	0.00	0.00	0.00	0.00	00
Total :	50.76	50.76	50.76	50.76	01
Total Number of Same Buildings	1				
Total :	50.76	50.76	50.76	50.76	01

SCHEDULE OF DOOR:

BUILDING NAME	NAME	LENGTH	HEIGHT	NOS
A (RESIDENTIAL)	D	0.89	2.10	02
A (RESIDENTIAL)	D	0.90	2.10	02

SCHEDULE OF WINDOW/VENTILATION:

BUILDING NAME	NAME	LENGTH	HEIGHT	NOS
A (RESIDENTIAL)	V	0.90	0.60	01
A (RESIDENTIAL)	W	1.03	1.20	05

UnitBUA Table for Building :A (RESIDENTIAL)

FLOOR	Name	UnitBUA Type	UnitBUA Area	Carpet Area	No. of Rooms	No. of Tenement
GROUND FLOOR PLAN	SPLIT A	FLAT	40.76	40.38	4	1
Total:	-	-	40.76	40.38	4	1

LTP NAME AND SIGNATURE	STRUCTURAL ENG'S NAME AND SIGNATURE	BUILDER NAME AND SIGNATURE	DIGITAL SIGNATURE
RANJIT KUMAR MNNP/ENG/0001/2016			