

Proposal Basic Information

Proposal File No.	MNNP/BP/0018/W08/2024
Owner Name	Rita Devi
Khata No	1
Plot No	21
Village Name	Baralota
Use	Residential
SubUse	Bungalow Dwelling / Non Apartment

FAR & Tenement Details (Table 4c-1)

Building	No. of Same Bldg	Total Built Up Area (Sq.mt.)	Proposed FAR Area (Sq.mt.) Resi.	Total FAR Area (Sq.mt.)	Total Consumed Additional FAR Area (Sq.mt.)	Tnmt (No.)
A (RESIDENTIAL)	1	156.74	156.74	156.74	156.74	01
Grand Total :	1	156.74	156.74	156.74	156.74	01

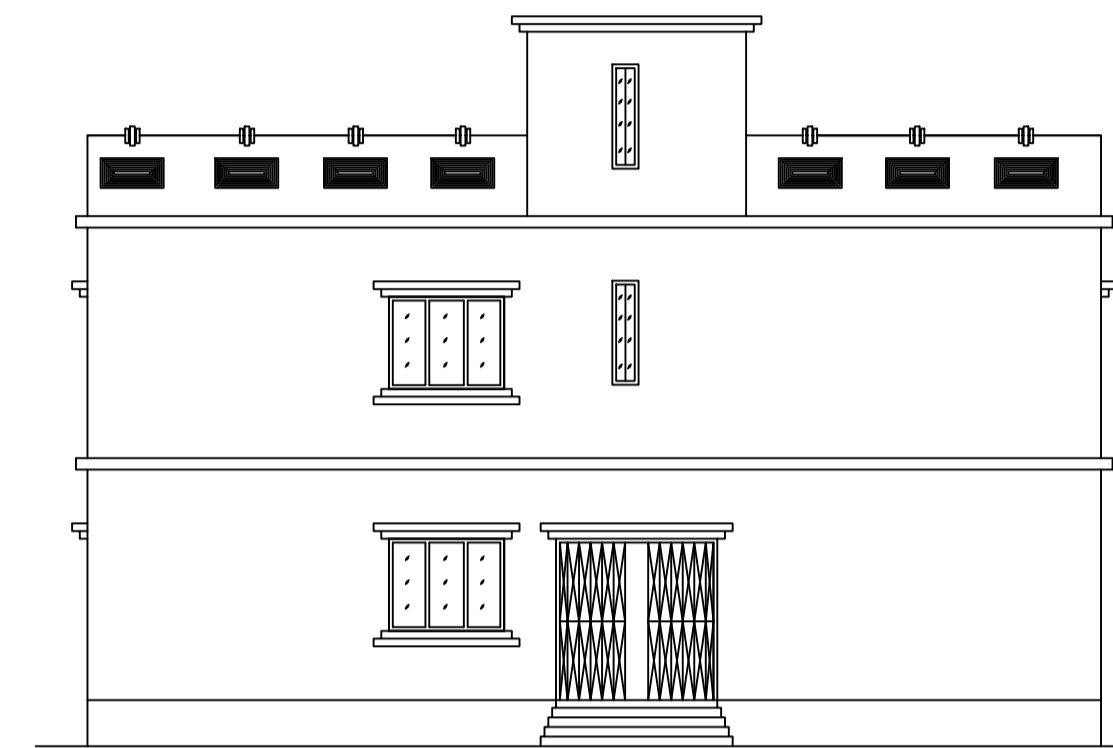
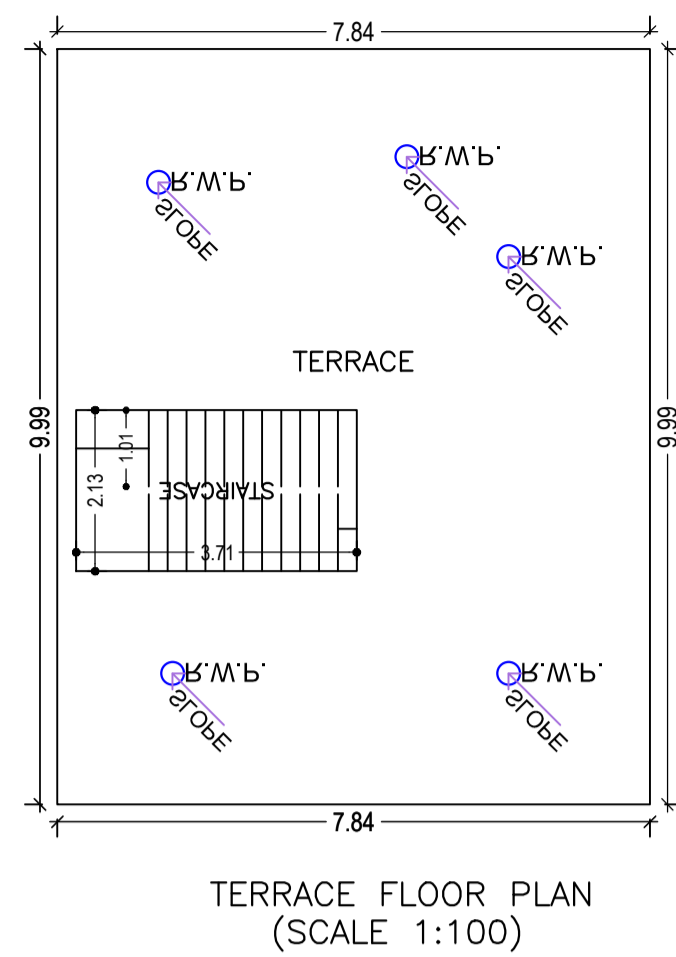
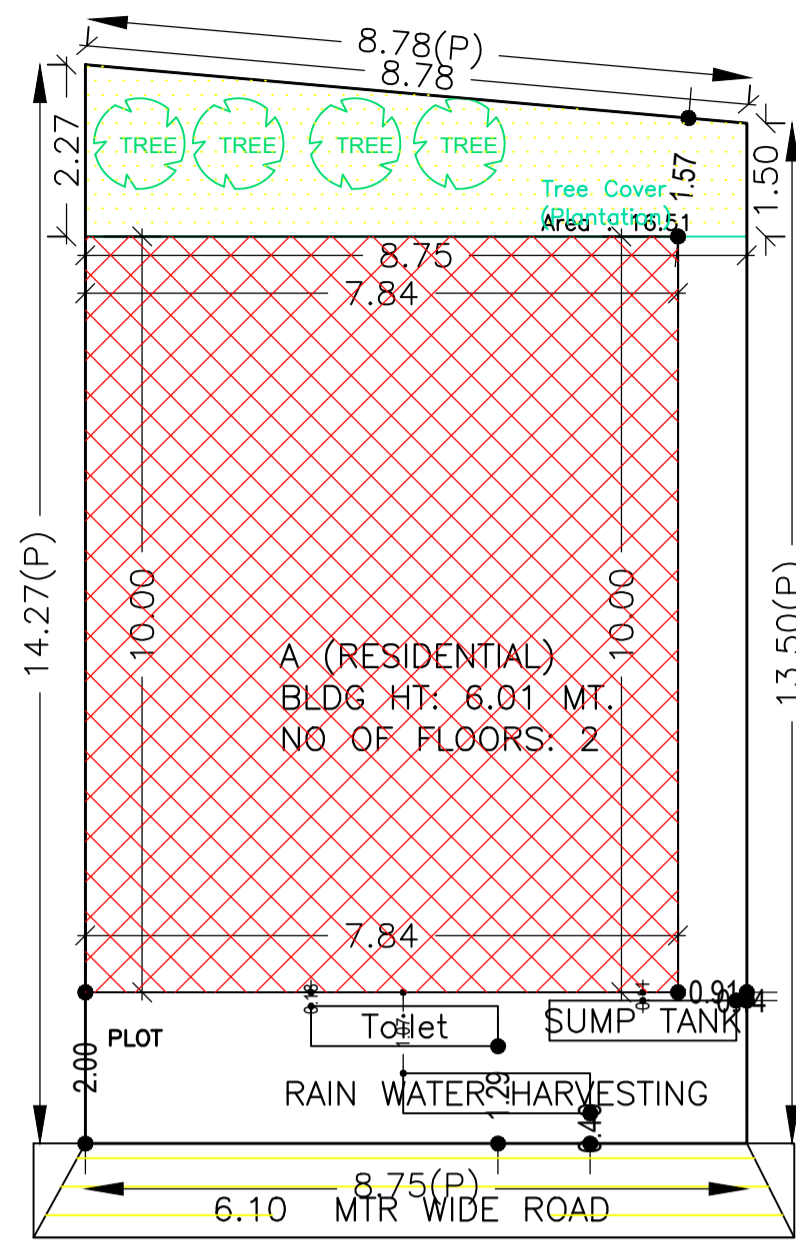

CROSS ELEVATION

AREA STATEMENT		VERSION NO. : 1.0.68
MEDINAGAR MUNICIPAL CORPORATION		VERSION DATE: 16/10/2020
PROJECT DETAIL:		
Region : JHARKHAND URBAN LOCAL BODIES	Plot Use: Residential	
District: PALAMU	Plot SubUse: Bungalow/ Dwelling / Non Apartment	
Authority: MEDINAGAR MUNICIPAL CORPORATION	Plot/Nearby/Religious/Structure: NA	
Inward No: MNNP/BP/0018/W08/2024	Plot/SubPlot No: 21	
Application Type: General Proposal	North: -	
Project Type: Building Permission	South: -	
Nature of Development: New	East: -	
Location of Development Area: New Area	West: -	
AREA DETAILS:		
AREA OF PLOT (Minimum)	(A)	SQ.MT. 121.44
NET AREA OF PLOT(Gross Plot Area - Deduction from Gross Plot area)	(A-Deductions)	121.44
Deduction for Balance Plot Area(from Gross Plot Area)		
Common Plot		16.51
Total		16.51
BALANCE AREA OF PLOT(Net Plot Area - Recreational/Amenity space)	(A-Deductions)	104.93
PLOT AREA FOR COVERAGE(Net Plot Area)	(A-Deductions)	121.44
Plot Area for FAR (Net Plot Area + Road Widening Area)	(A-Deductions)	121.44
COVERAGE CHECK		
Permissible Coverage area (70.00 %)		85.01
Proposed Coverage Area (64.53 %)		78.37
Total Prop. Coverage Area (64.53 %)		78.37
Balance coverage area (5.47 %)		6.64
FAR CHECK		
Perm. FAR Area (2.000)		242.88
Total Perm. FAR area		242.88
Residential FAR		156.73
Proposed FAR Area		156.73
Total Proposed FAR Area		156.73
Consumed FAR (Factor)		1.29
Balance FAR Area		86.15
BUILT UP AREA CHECK		
Total Proposed BuiltUp Area		156.74
ARCHITECT (Regd) RANJIT KUMAR		
ENGINEER (Regd)		
SUPERVISOR (Regd)		
OWNER (Regd) Rita Devi		
DEVELOPMENT AUTHORITY		LOCAL BODY

SITE PLAN

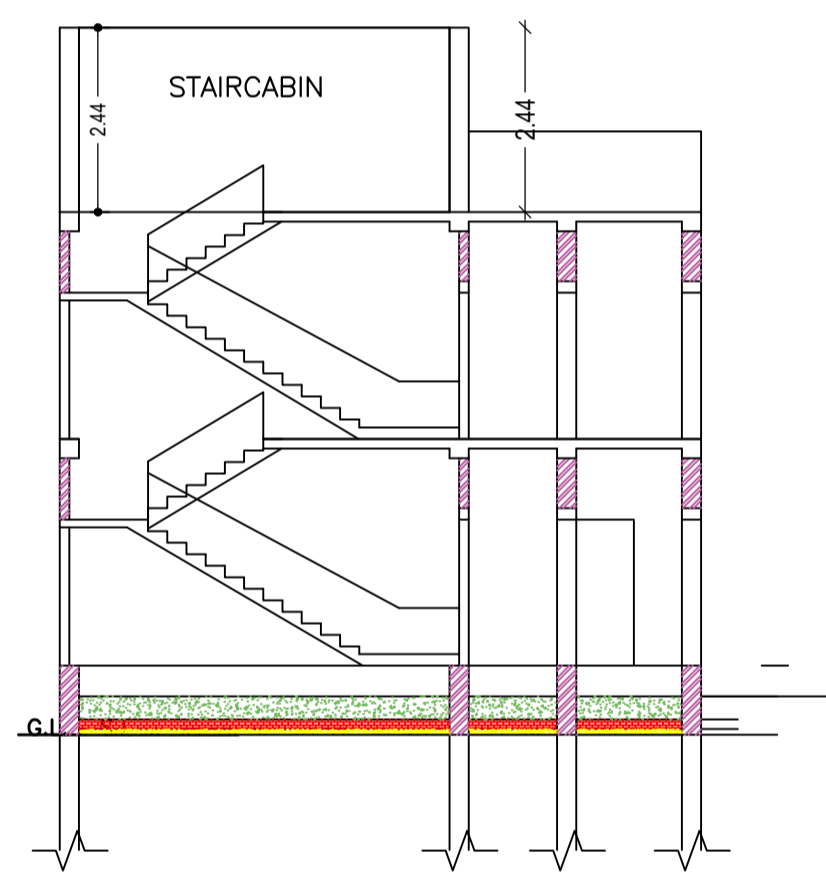
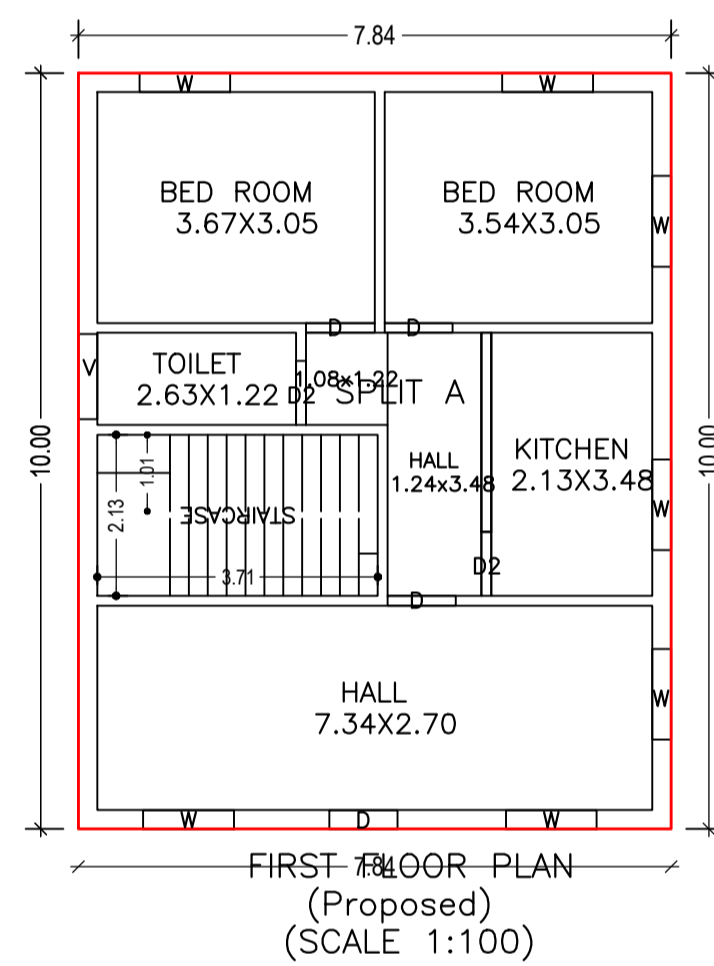
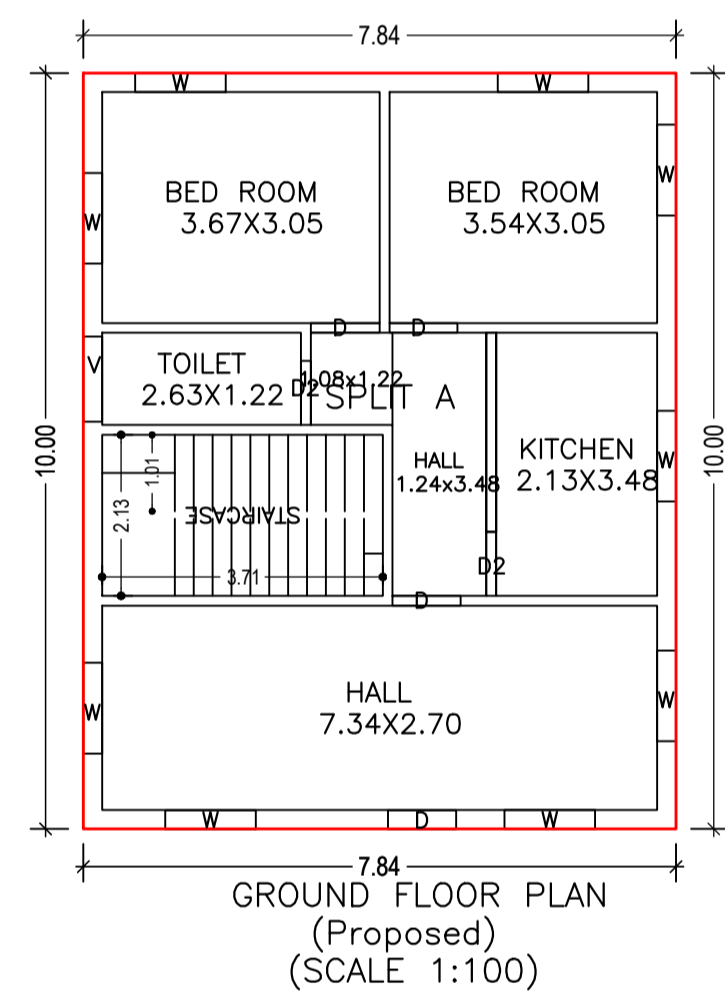

CROSS SECTION (A)

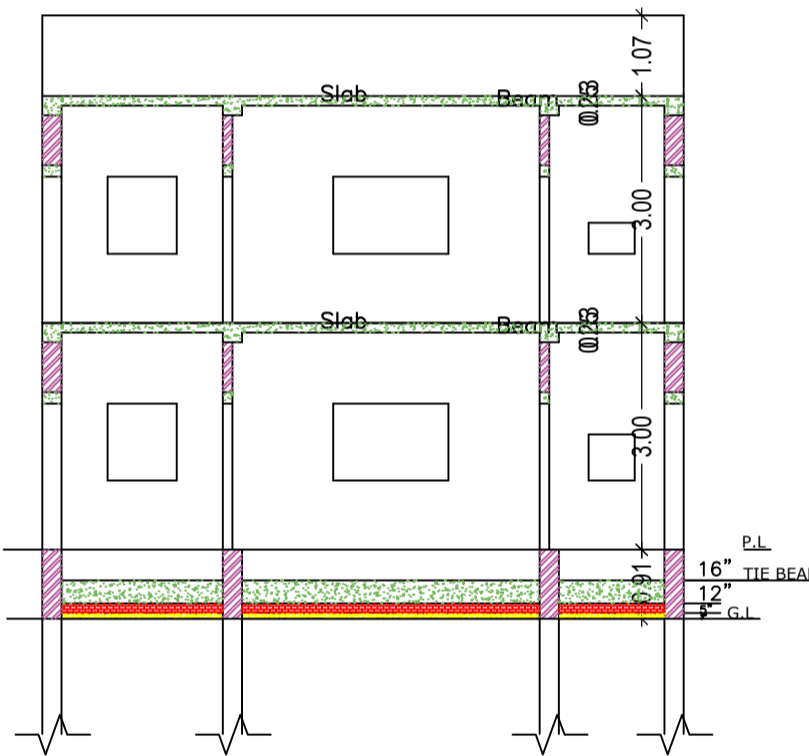

CROSS SECTION (B)

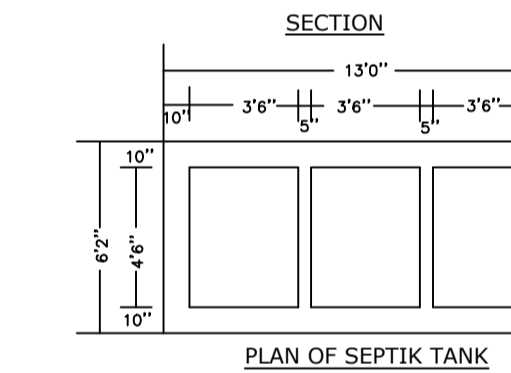
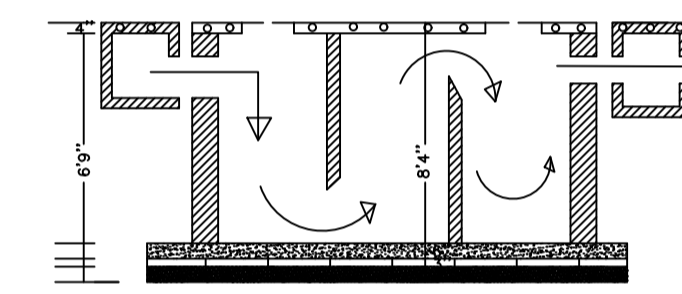

PLAN OF SEPTIK TANK

COLOR INDEX	
PLOT BOUNDARY	Black
ABUTTING ROAD	Red
PROPOSED CONSTRUCTION	Green
COMMON PLOT	Yellow
ROAD WIDENING AREA	Blue
EXISTING (To be retained)	Light Blue
EXISTING (To be demolished)	White

Buildingwise Floor FAR Details

Floor Name	Building Name A (RESIDENTIAL)		Total	
	Proposed Built Up Area (Sq.mt.)	Proposed FAR Area (Sq.mt.)	Total Proposed Built Up Area (Sq.mt.)	Total FAR Area (Sq.mt.)
Ground Floor	78.37	78.37	78.37	78.37
First Floor	78.37	78.37	78.37	78.37
Terrace Floor	0.00	0.00	0.00	0.00
Total :	156.74	156.74	156.74	156.74

Building USE/SUBUSE Details

Building Name	Building Use	Building SubUse	Building Structure
A (RESIDENTIAL)	Residential	Bungalow Dwelling / Non Apartment	Non-Highrise

Building :A (RESIDENTIAL)

Floor Name	Total Built Up Area (Sq.mt.)	Proposed FAR Area (Sq.mt.) Resi.	Total FAR Area (Sq.mt.)	Total Consumed Additional FAR Area (Sq.mt.)	Tnmt (No.)
Ground Floor	78.37	78.37	78.37	78.37	01
First Floor	78.37	78.37	78.37	78.37	00
Terrace Floor	0.00	0.00	0.00	0.00	00
Total :	156.74	156.74	156.74	156.74	01
Total Number of Same Buildings	1				
Total :	156.74	156.74	156.74	156.74	01

SCHEDULE OF DOOR:

BUILDING NAME	NAME	LENGTH	HEIGHT	NOS
A (RESIDENTIAL)	D2	0.85	2.10	04
A (RESIDENTIAL)	D	0.90	2.10	06
A (RESIDENTIAL)	D	0.91	2.10	02

SCHEDULE OF WINDOW/VENTILATION:

BUILDING NAME	NAME	LENGTH	HEIGHT	NOS
A (RESIDENTIAL)	V	1.13	0.90	02
A (RESIDENTIAL)	W	1.20	1.20	16

UnitBUA Table for Building :A (RESIDENTIAL)

FLOOR	Name	UnitBUA Type	UnitBUA Area	Carpet Area	No. of Rooms	No. of Tenement
FIRST FLOOR PLAN	SPLIT A	FLAT	0.00	0.00	6	0
GROUND FLOOR PLAN	SPLIT A	FLAT	138.84	138.15	6	1
Total:	-	-	138.84	138.15	12	1

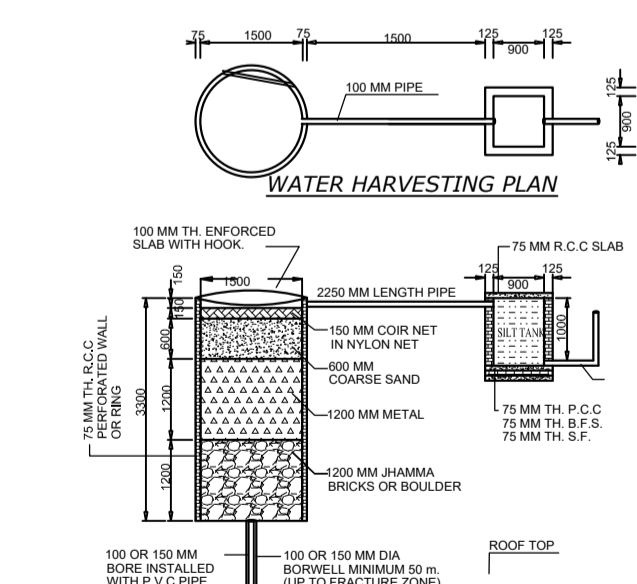
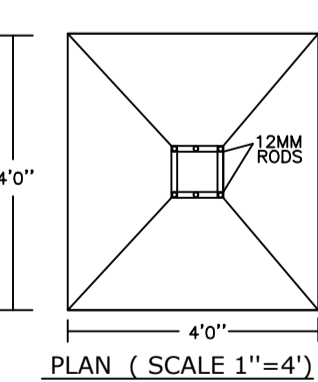
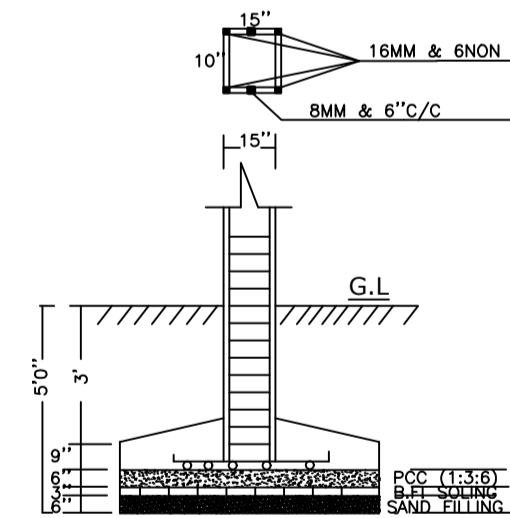

LTP NAME AND SIGNATURE	STRUCTURAL ENG'S NAME AND SIGNATURE	BUILDER NAME AND SIGNATURE	DIGITAL SIGNATURE
RANJIT KUMAR MNNP/ENG/0001/2016			