

SITE PLAN

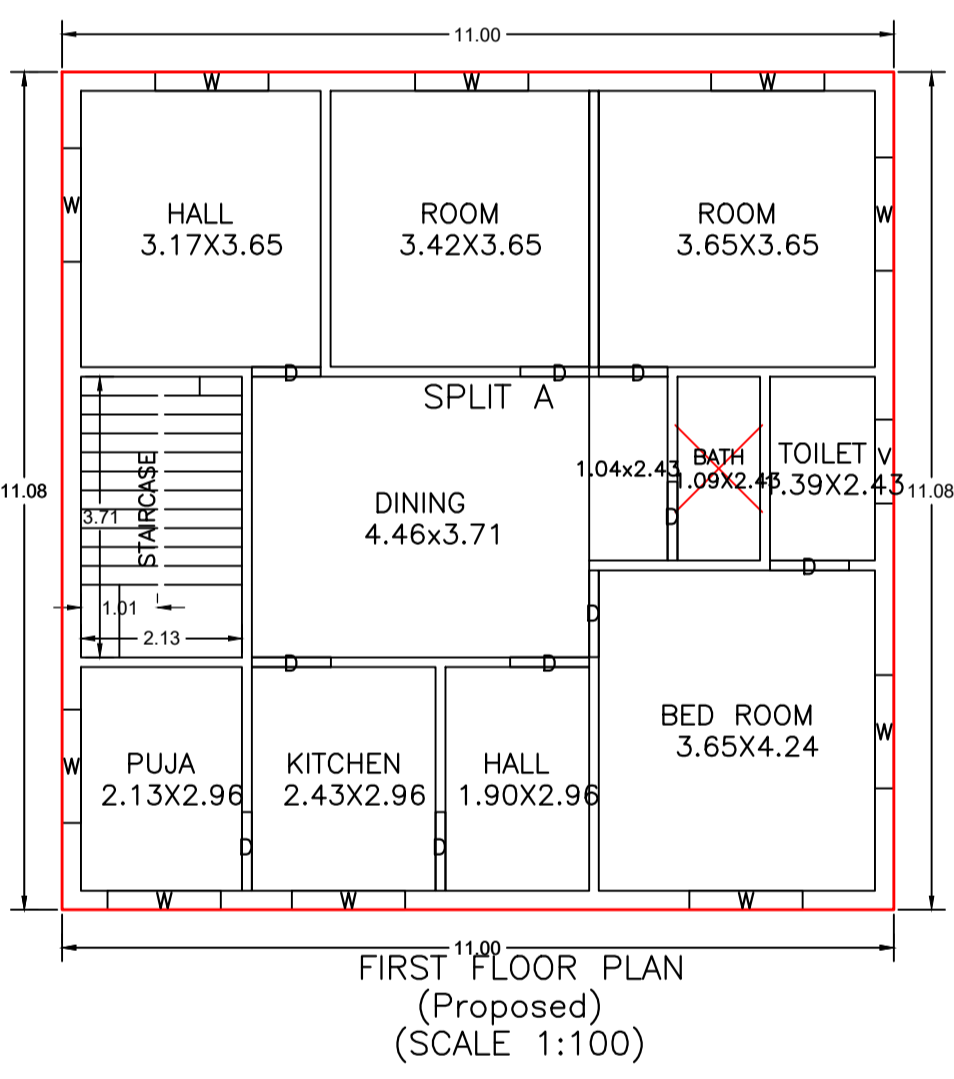
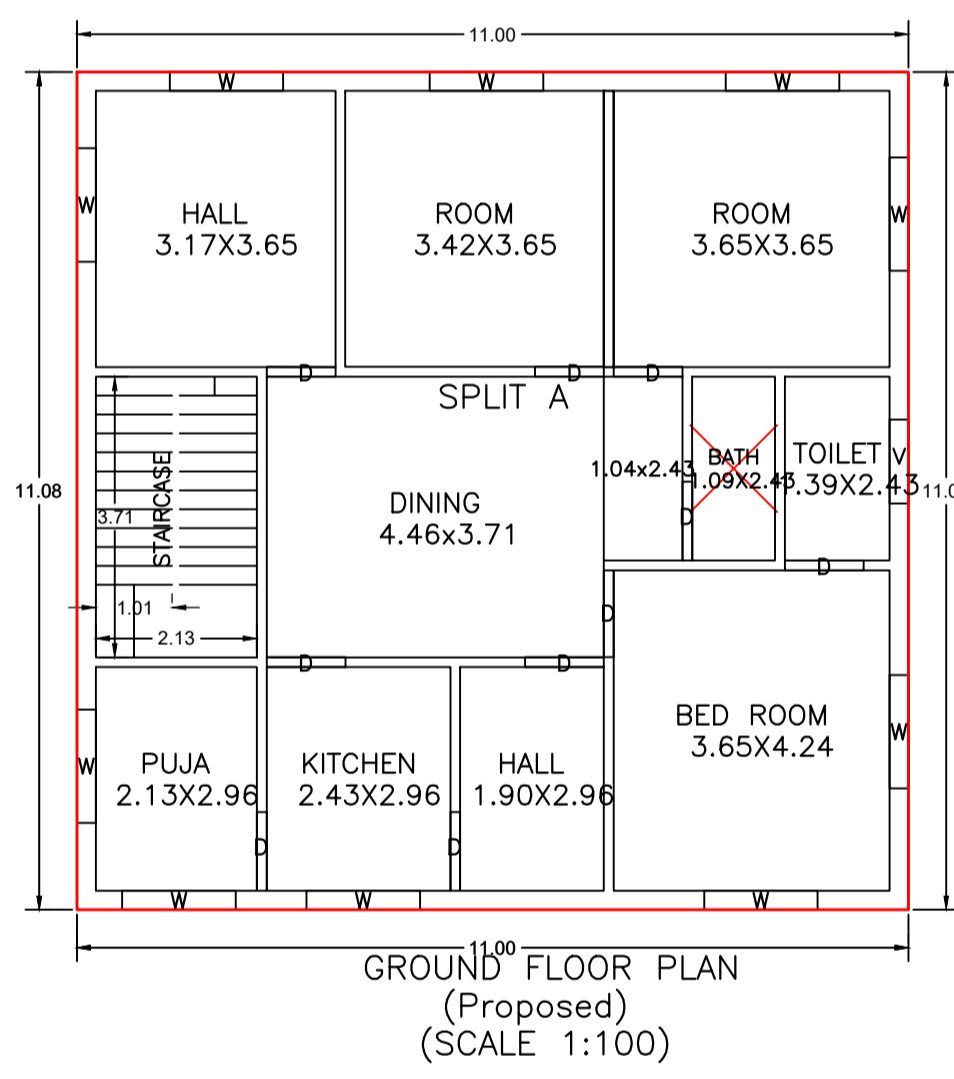

Building :A (RESIDENTIAL)

Floor Name	Total Built Up Area (Sq.mt.)	Proposed FAR Area (Sq.mt.)	Total FAR Area (Sq.mt.)	Total Consumed Additional FAR Area (Sq.mt.)	Tnmt (No.)
Ground Floor	121.88	121.88	121.88	121.88	01
First Floor	121.88	121.88	121.88	121.88	00
Terrace Floor	0.00	0.00	0.00	0.00	00
Total :	243.76	243.76	243.76	243.76	01
Total Number of Same Buildings	1				
Total :	243.76	243.76	243.76	243.76	01

SCHEDULE OF DOOR:

BUILDING NAME	NAME	LENGTH	HEIGHT	NOS
A (RESIDENTIAL)	D	0.91	2.10	06
A (RESIDENTIAL)	D	1.04	2.10	12
A (RESIDENTIAL)	D	1.15	2.10	02

SCHEDULE OF WINDOW/VENTILATION:

BUILDING NAME	NAME	LENGTH	HEIGHT	NOS
A (RESIDENTIAL)	V	1.11	1.20	02
A (RESIDENTIAL)	W	1.50	1.20	20

UnitBUA Table for Building :A (RESIDENTIAL)

FLOOR	Name	UnitBUA Type	UnitBUA Area	Carpet Area	No. of Rooms	No. of Tenement
GROUND FLOOR PLAN	SPLIT A	FLAT	226.09	225.14	10	1
FIRST FLOOR PLAN	SPLIT A	FLAT	0.00	0.00	10	0
Total:	-	-	226.09	225.14	20	1

Building USE/SUBUSE Details

Building Name	Building Use	Building SubUse	Building Structure	Floor Name	Floor Use	Floor SubUse	FAR Name	FAR Use	FAR SubUse
A (RESIDENTIAL)	Residential	Bungalow/ Dwelling / Non Apartment	Non-Highrise	TERRACE FLOOR PLAN	Residential	Bungalow/ Dwelling / Non Apartment	-	-	-
				GROUND FLOOR PLAN	Residential	Bungalow/ Dwelling / Non Apartment	Residential FAR	Residential	Bungalow/ Dwelling / Non Apartment
				FIRST FLOOR PLAN	Residential	Bungalow/ Dwelling / Non Apartment	Residential FAR	Residential	Bungalow/ Dwelling / Non Apartment

Proposal Basic Information

Proposal File No.	MNNP/BP/0191/W04/2024
Owner Name	JAGDISH RAM
Khata No	192
Plot No	40
Village Name	Baralota
Use	Residential
SubUse	Bungalow/ Dwelling / Non Apartment

AREA STATEMENT

AREA DETAILS:	AREA OF PLOT (Minimum)	SQ.MT.
AREA OF PLOT (Minimum)	(A)	212.53
Deduction for NetPlot Area		
Surrender Free of Cost		19.52
Total		19.52
NET AREA OF PLOT (Gross Plot Area - Deduction from Gross Plot area)	(A-Deductions)	193.01
Deduction for Balance Plot Area (from Gross Plot Area)		
Surrender Free of Cost		19.52
Common Plot		19.20
Total		38.72
BALANCE AREA OF PLOT (Net Plot Area - Recreational/Amenity space)	(A-Deductions)	173.81
PLOT AREA FOR COVERAGE (Net Plot Area)	(A-Deductions)	193.01
Plot Area for FAR (Net Plot Area + Road/Widening Area)	(A-Deductions)	212.53
COVERAGE CHECK		
Permissible Coverage area (70.00 %)		135.11
Proposed Coverage Area (63.15 %)		121.88
Total Prop. Coverage Area (63.15 %)		121.88
Balance coverage area (6.85 %)		13.23
FAR CHECK		
Perm. FAR Area (1,200)		255.04
Total Perm. FAR area		255.04
Residential FAR		243.75
Proposed FAR		243.75
Total Proposed FAR Area		243.75
Consumed FAR (Factor)		1.15
Balance FAR Area		11.29
BUILT UP AREA CHECK		
Total Proposed BuiltUp Area		243.76
ARCHITECT (Regd)	Umesh Prasad	
ENGINEER (Regd)		
SUPERVISOR (Regd)		
OWNER (Regd)	JAGDISH RAM	
DEVELOPMENT AUTHORITY	LOCAL BODY	

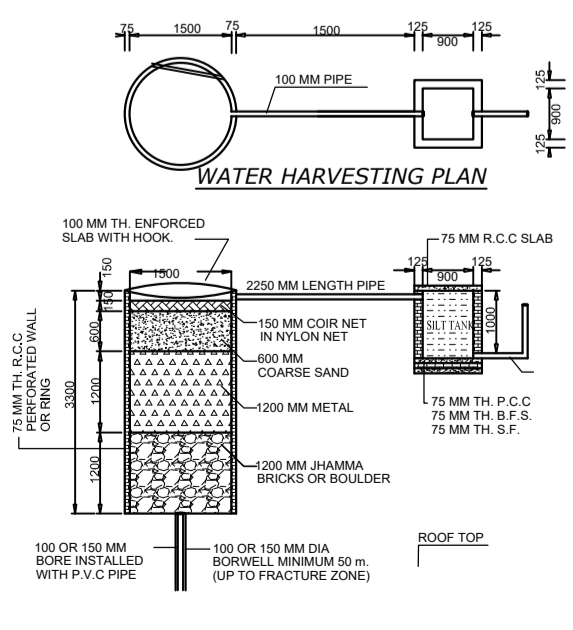
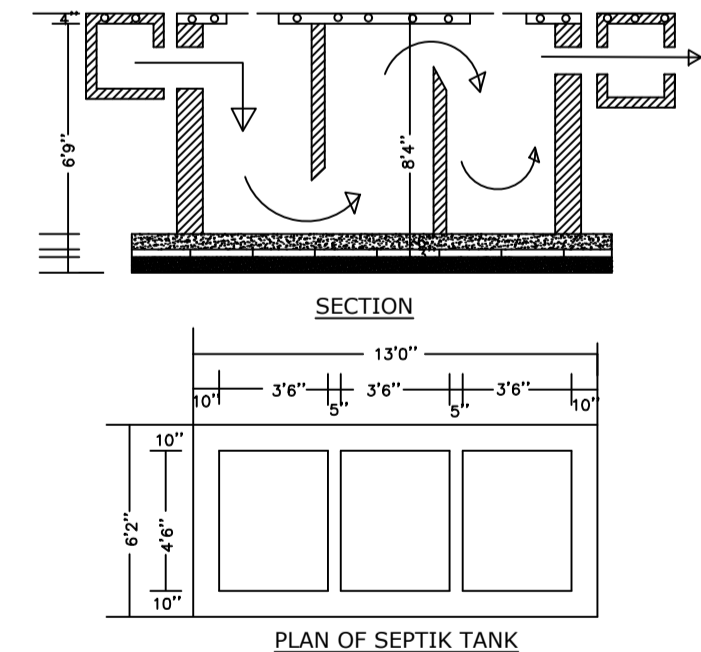
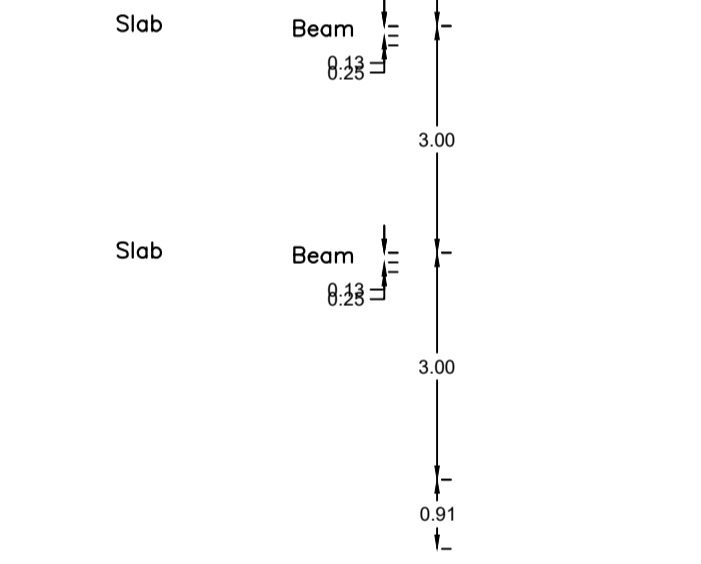
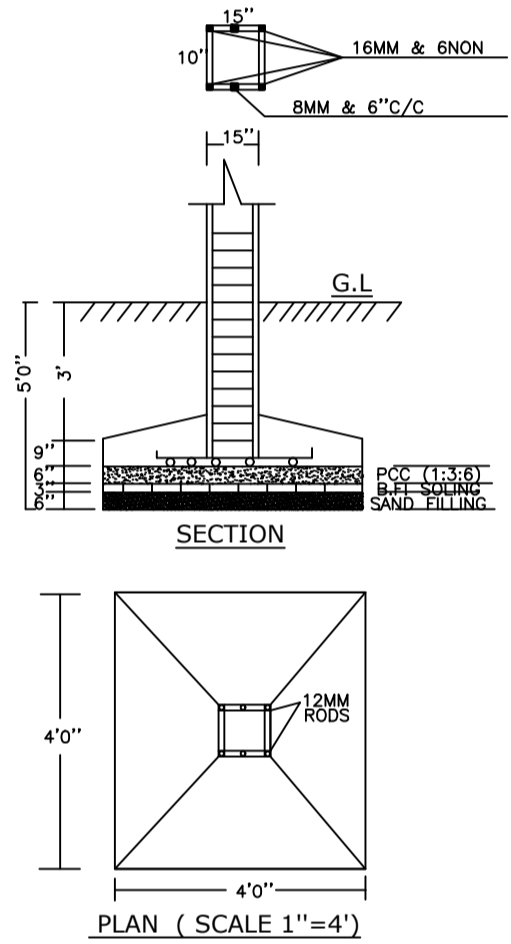

COLOR INDEX

PLOT BOUNDARY	Black
ABUTTING ROAD	Green
PROPOSED CONSTRUCTION	Red
COMMON PLOT	Yellow
ROAD WIDENING AREA	Blue
EXISTING (To be retained)	Orange
EXISTING (To be demolished)	White

Buildingwise Floor FAR Details

Floor Name	Building Name A (RESIDENTIAL)		Total	
	Proposed Built Up Area (Sq.mt.)	Proposed FAR Area (Sq.mt.)	Total Proposed Built Up Area (Sq.mt.)	Total FAR Area (Sq.mt.)
Ground Floor	121.88	121.88	121.88	121.88
First Floor	121.88	121.88	121.88	121.88
Terrace Floor	0.00	0.00	0.00	0.00
Total :	243.76	243.76	243.76	243.76

FAR & Tenement Details

Building	No. of Same Bldg	Total Built Up Area (Sq.mt.)	Proposed FAR Area (Sq.mt.)	Total FAR Area (Sq.mt.)	Total Consumed Additional FAR Area (Sq.mt.)	Tnmt (No.)
A (RESIDENTIAL)	1	243.76	243.76	243.76	243.76	01
Grand Total :	1	243.76	243.76	243.76	243.76	01

LTP NAME AND SIGNATURE Umesh Prasad MNNP/ENG/0002/2024	STRUCTURAL ENG'S NAME AND SIGNATURE	BUILDER NAME AND SIGNATURE	DIGITAL SIGNATURE
--	-------------------------------------	----------------------------	-------------------