

Proposal Basic Information	
Proposal File No.	MNNP/BP/0155/W08/2024
Owner Name	Vikash Kumar
Khata No	78
Plot No	156
Village Name	Baralota
Use	Residential
SubUse	Bungalow Dwelling / Non Apartment

FAR & Tenement Details (Table 4c-1)

Building	No. of Same Bldg	Total Built Up Area (Sq.mt.)	Proposed FAR Area (Sq.mt.) Resi.	Total FAR Area (Sq.mt.)	Total Consumed Additional FAR Area (Sq.mt.)	Tnmt (No.)
A (BUILDING)	1	85.96	85.96	85.96	85.96	01
Grand Total :	1	85.96	85.96	85.96	85.96	01

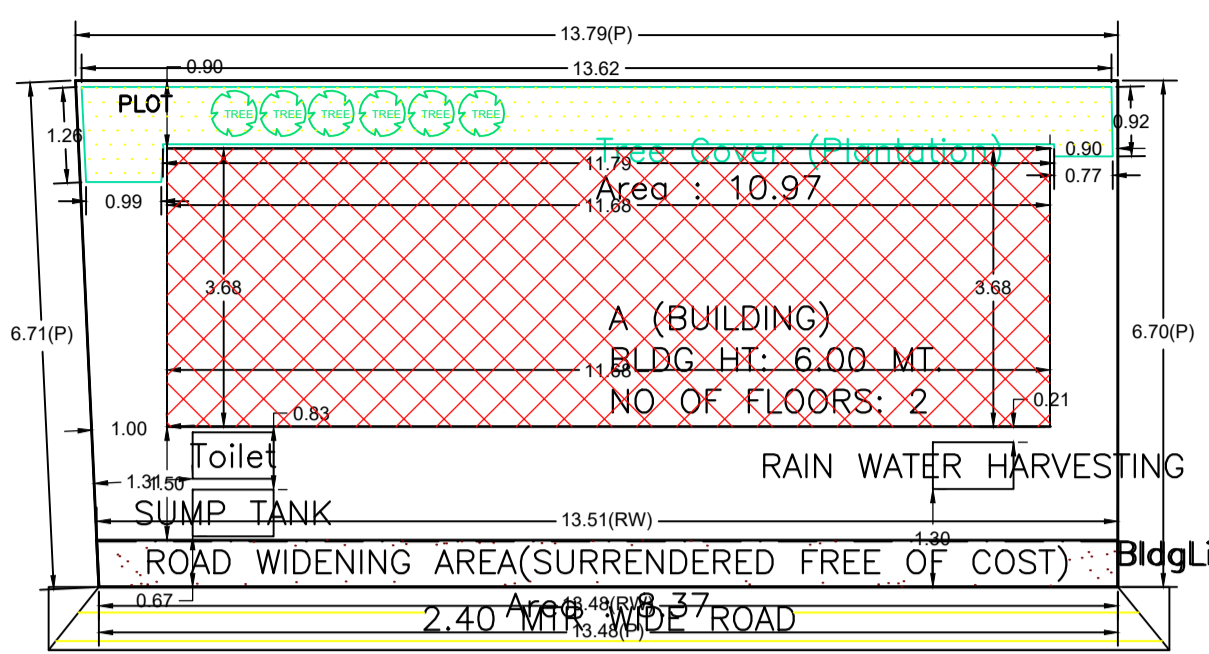

SITE PLAN

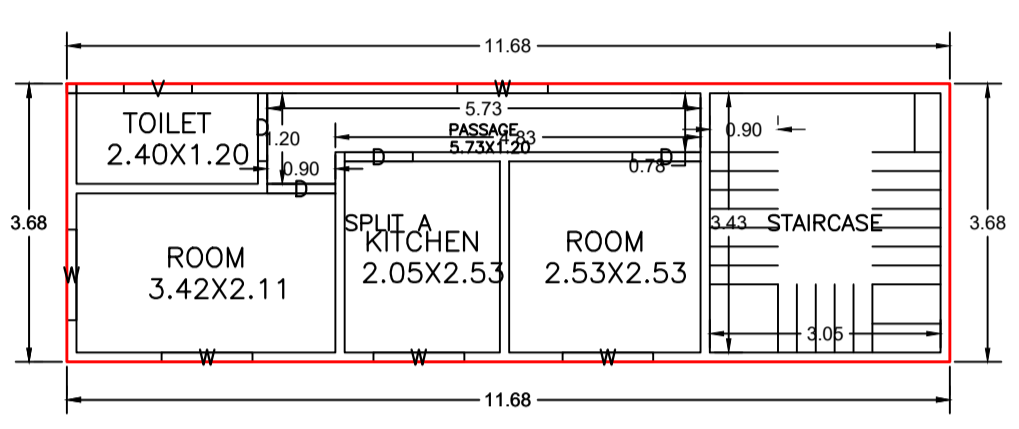

GROUND FLOOR PLAN (Proposed) (SCALE 1:100)

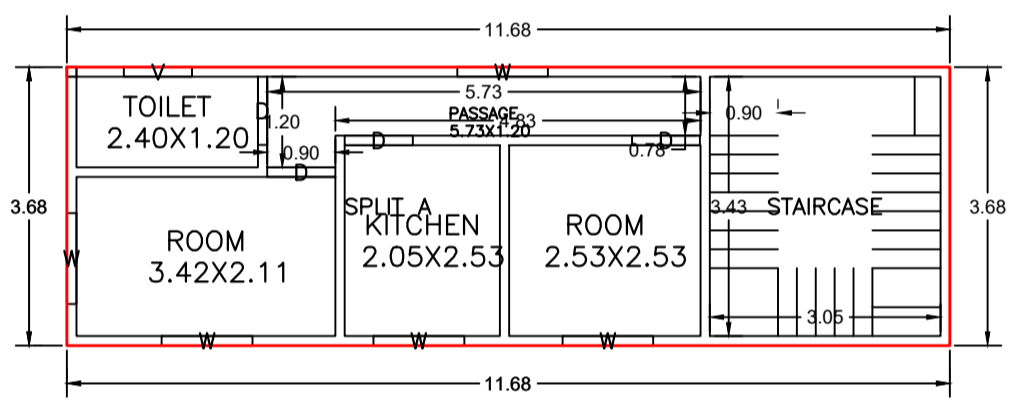

FIRST FLOOR PLAN (Proposed) (SCALE 1:100)

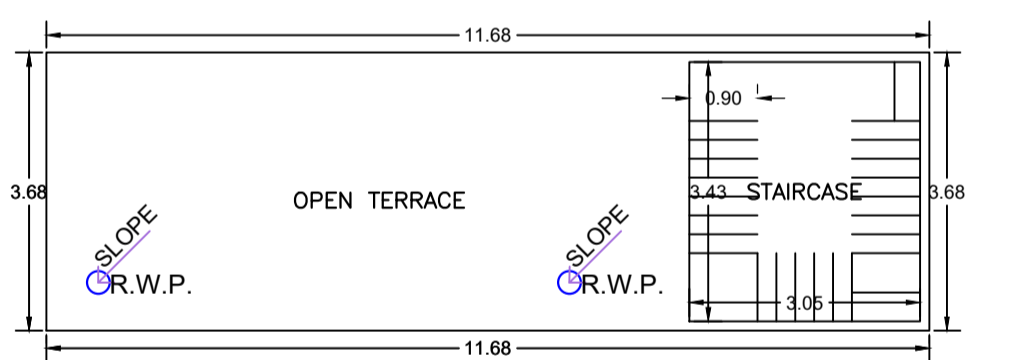

TERRACE FLOOR PLAN (Proposed) (SCALE 1:100)

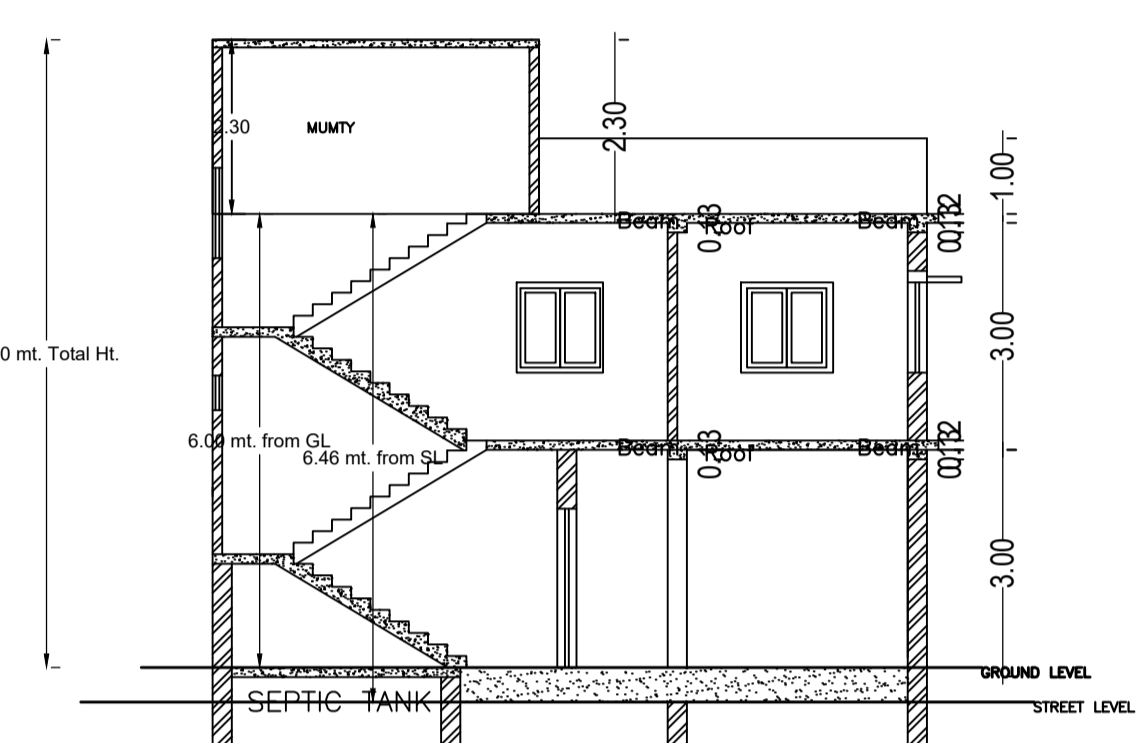

SECTION DETAILS (SCALE 1:100)

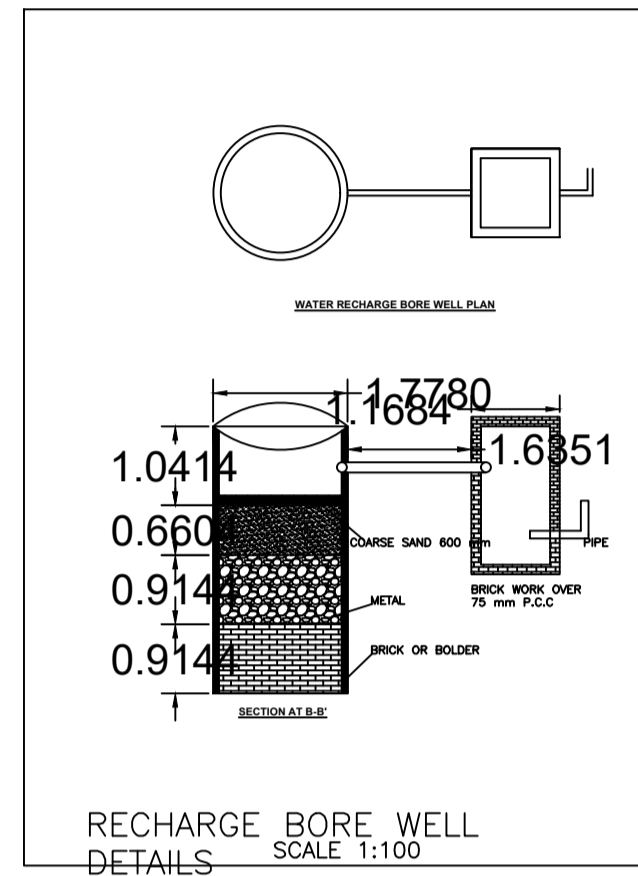

RECHARGE BORE WELL DETAILS (SCALE 1:100)

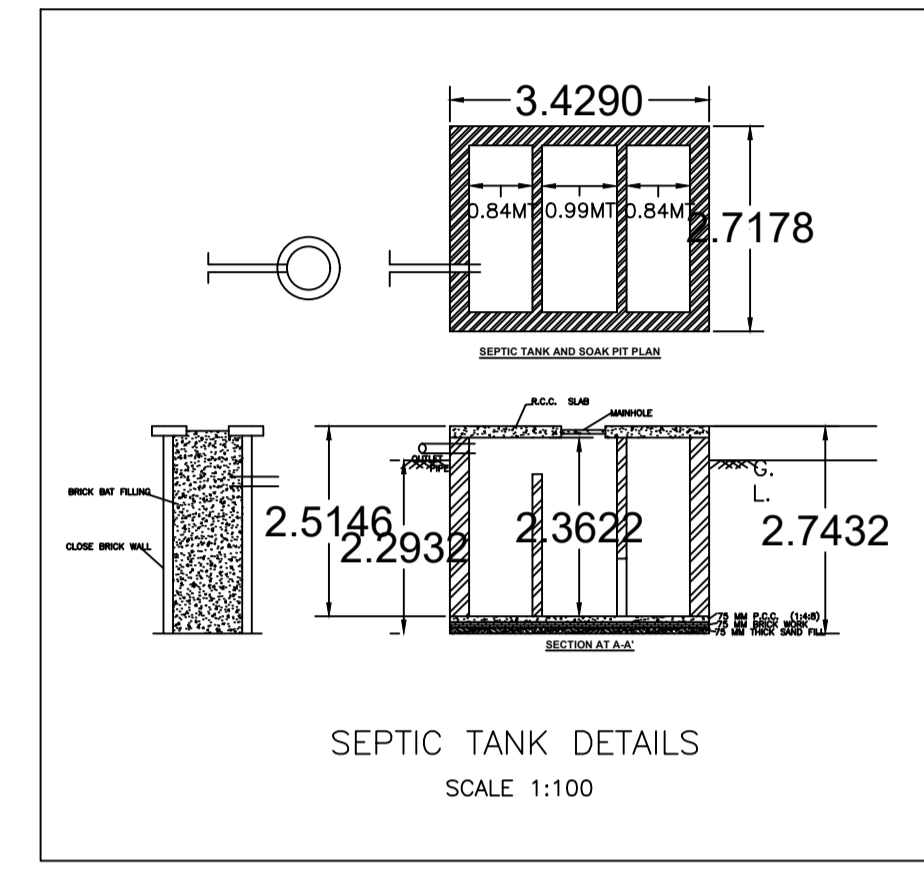

SEPTIC TANK DETAILS (SCALE 1:100)

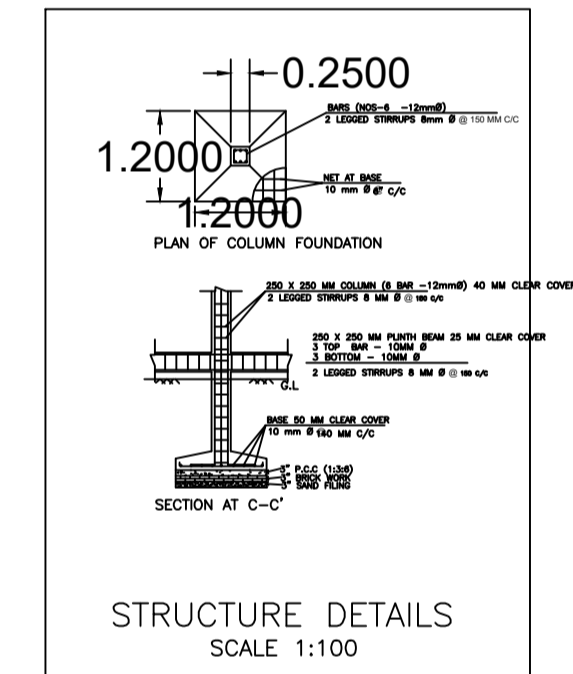

STRUCTURE DETAILS (SCALE 1:100)



FRONT ELEVATION (SCALE 1:100)

BACK ELEVATION (SCALE 1:100)

AREA STATEMENT		VERSION NO. : 1.070
MEDINAGAR MUNICIPAL CORPORATION		VERSION DATE: 18/10/2020
PROJECT DETAIL:		
Region : JHARKHAND URBAN LOCAL BODIES	Plot Use: Residential	
District: PALAMU	Plot SubUse: Bungalow Dwelling / Non Apartment	
Authority: MEDINAGAR MUNICIPAL CORPORATION	Plot/Nearby/Religious Structure: NA	
Inward No: MNNP/BP/0155/W08/2024	Plot/SubPlot No: 156	
Application Type: General Proposal	North: -	
Project Type: Building Permission	South: -	
Nature of Development: New	East: -	
Location of Development Area: Old	West: -	
AREA DETAILS:		
AREA OF PLOT (Minimum)	(A)	SQ.MT. 89.82
Deduction for NetPlot Area		
Surrender Free of Cost		8.37
Total		8.37
NET AREA OF PLOT(Gross Plot Area - Deduction from Gross Plot area)	(A-Deductions)	81.45
Deduction for Balance Plot Area(from Gross Plot Area)		
Surrender Free of Cost		8.37
Common Plot		10.97
Total		19.33
BALANCE AREA OF PLOT(Net Plot Area - Recreational/Amenity space)	(A-Deductions)	70.49
PLOT AREA FOR COVERAGE(Net Plot Area)	(A-Deductions)	81.45
Plot Area for FAR (Net Plot Area + Road Widening Area)	(A-Deductions)	89.82
COVERAGE CHECK		
Permissible Coverage area ( 70.00 % )		57.01
Proposed Coverage Area ( 52.77 % )		42.98
Total Prop. Coverage Area ( 52.77 % )		42.98
Balance coverage area ( 17.22 % )		14.03
FAR CHECK		
Perm. FAR Area ( 1.200 )		107.78
Total Perm. FAR area		107.78
Residential FAR		85.96
Proposed FAR Area		85.96
Total Proposed FAR Area		85.96
Consumed FAR (Factor)		0.96
Balance FAR Area		21.82
BUILT UP AREA CHECK		
Total Proposed BuiltUp Area		85.96
ARCHITECT (Regd)	PANKAJ KUMAR SINGH	
ENGINEER (Regd)		
SUPERVISOR (Regd)		
OWNER (Regd)	Vikash Kumar	
DEVELOPMENT AUTHORITY		LOCAL BODY

COLOR INDEX	
PLOT BOUNDARY	Black
ABUTTING ROAD	Red
PROPOSED CONSTRUCTION	Green
COMMON PLOT	Yellow
ROAD WIDENING AREA	Blue
EXISTING (To be retained)	Orange
EXISTING (To be demolished)	Purple

Buildingwise Floor FAR Details

Floor Name	Building Name A (BUILDING)		Total	
	Proposed Built Up Area (Sq.mt.)	Proposed FAR Area (Sq.mt.)	Total Proposed Built Up Area (Sq.mt.)	Total FAR Area (Sq.mt.)
Ground Floor	42.98	42.98	42.98	42.98
First Floor	42.98	42.98	42.98	42.98
Terrace Floor	0.00	0.00	0.00	0.00
Total :	85.96	85.96	85.96	85.96

Building USE/SUBUSE Details

Building Name	Building Use	Building SubUse	Building Structure
A (BUILDING)	Residential	Bungalow Dwelling / Non Apartment	Non-Highrise

Building :A (BUILDING)

Floor Name	Total Built Up Area (Sq.mt.)	Proposed FAR Area (Sq.mt.) Resi.	Total FAR Area (Sq.mt.)	Total Consumed Additional FAR Area (Sq.mt.)	Tnmt (No.)
Ground Floor	42.98	42.98	42.98	42.98	01
First Floor	42.98	42.98	42.98	42.98	00
Terrace Floor	0.00	0.00	0.00	0.00	00
Total :	85.96	85.96	85.96	85.96	01
Total Number of Same Buildings :	1				
Total :	85.96	85.96	85.96	85.96	01

SCHEDULE OF DOOR:

BUILDING NAME	NAME	LENGTH	HEIGHT	NOS
A (BUILDING)	D	0.90	2.10	08

SCHEDULE OF WINDOW/VENTILATION:

BUILDING NAME	NAME	LENGTH	HEIGHT	NOS
A (BUILDING)	V	0.90	0.60	02
A (BUILDING)	W	1.20	1.20	10

UnitBUA Table for Building :A (BUILDING)

FLOOR	Name	UnitBUA Type	UnitBUA Area	Carpet Area	No. of Rooms	No. of Tenement
GROUND FLOOR PLAN	SPLIT A	FLAT	62.60	62.57	5	1
FIRST FLOOR PLAN	SPLIT A	FLAT	0.00	0.00	5	0
Total:	-	-	62.60	62.57	10	1

LTP NAME AND SIGNATURE	STRUCTURAL ENG'S NAME AND SIGNATURE	BUILDER NAME AND SIGNATURE	DIGITAL SIGNATURE
PANKAJ KUMAR SINGH MNNP/ENG/006/2019			