

SITE PLAN SCALE 1:100

FAR & Tenement Details (Table 4c-1)

Building	No. of Same Bldg	Total Built Up Area (Sq.mt.)	Deductions (Area in Sq.mt.)	Proposed FAR Area (Sq.mt.)	Total FAR Area (Sq.mt.)	Total Consumed Additional FAR Area (Sq.mt.)	Trmt (No.)
A (RAM B)	1	234.88	Parking 36.71	198.17	198.17	198.17	01
Grand Total :	1	234.88	36.71	198.17	198.17	198.17	01

Proposal Basic Information

Proposal File No.	MNNP/BP/0161/W19/2024
Owner Name	RAM BABU
Khata No	501
Plot No	2225
Village Name	Redma
Use	Residential
SubUse	Bungalow/ Dwelling / Non Apartment

AREA STATEMENT	VERSION NO. : 1.0.70
MEDININAGAR MUNICIPAL CORPORATION	VERSION DATE: 16/10/2020
PROJECT DETAIL:	
Region : JHARKHAND URBAN LOCAL BODIES	Plot Use: Residential
District: PALAMU	Plot SubUse: Bungalow/ Dwelling / Non Apartment
Authority: MEDININAGAR MUNICIPAL CORPORATION	PlotNearbyReligiousStructure: NA
Inward No: MNNP/BP/0161/W19/2024	Plot/SubPlot No: 2225
Application Type: General Proposal	North: Plot No. - ram babu
Project Type: Building Permission	South: Plot No. - after road naval kishor singh
Nature of Development: New	East: Road Width - 4.75
Location of Development Area: New	West: Plot No. - uma devi
AREA DETAILS:	
AREA OF PLOT (Minimum)	(A) 199.73
Deduction for NetPlot Area	
Surrender Free of Cost	11.05
Total	11.05
NET AREA OF PLOT(Gross Plot Area - Deduction from Gross Plot area)	(A-Deductions) 188.69
Deduction for Balance Plot Area(from Gross Plot Area)	
Surrender Free of Cost	11.05
Common Plot	21.32
Total	32.36
BALANCE AREA OF PLOT(Net Plot Area - Recreational/Amenity space)	(A-Deductions) 167.37
PLOT AREA FOR COVERAGE(Net Plot Area)	(A-Deductions) 188.69
Plot Area for FAR (Net Plot Area + RoadWidening Area)	(A-Deductions) 199.73
COVERAGE CHECK	
Permissible Coverage area (70.00 %)	132.08
Proposed Coverage Area (62.24 %)	117.44
Total Prop. Coverage Area (62.24 %)	117.44
Balance coverage area (7.76 %)	14.64
FAR CHECK	
Perm. FAR Area (1.500)	299.60
Total Perm. FAR area	299.60
Residential FAR	198.17
Proposed FAR Area	198.17
Total Proposed FAR Area	198.17
Consumed FAR (Factor)	0.99
Balance FAR Area	101.43
BUILT UP AREA CHECK	
Total Proposed BuiltUp Area	234.88
ARCHITECT (Regd)	MANORANJAN KUMAR SINGH
ENGINEER (Regd)	
SUPERVISOR (Regd)	
OWNER (Regd)	RAM BABU
DEVELOPMENT AUTHORITY LOCAL BODY	

COLOR INDEX	
PLOT BOUNDARY	Black
ABUTTING ROAD	Green
PROPOSED CONSTRUCTION	Red
COMMON PLOT	Yellow
ROAD WIDENING AREA	Orange
EXISTING (To be retained)	Blue
EXISTING (To be demolished)	Light Blue

Buildingwise Floor FAR Details

Floor Name	Building Name A (RAM B)		Total	
	Proposed Built Up Area (Sq.mt.)	Proposed FAR Area (Sq.mt.)	Total Proposed Built Up Area (Sq.mt.)	Total FAR Area (Sq.mt.)
Ground Floor	117.44	80.73	117.44	80.73
First Floor	117.44	117.44	117.44	117.44
Terrace Floor	0.00	0.00	0.00	0.00
Total :	234.88	198.17	234.88	198.17

Building USE/SUBUSE Details

Building Name	Building Use	Building SubUse	Building Structure
A (RAM B)	Residential	Bungalow/ Dwelling / Non Apartment	Non-Highrise

LTP NAME AND SIGNATURE	STRUCTURAL ENG'S NAME AND SIGNATURE	BUILDER NAME AND SIGNATURE	DIGITAL SIGNATURE
MANORANJAN KUMAR SINGH MNNP/ENG/0003/2024			

Proposal Basic Information	
Proposal File No.	MNNP/BP/0161/W19/24
Owner Name	RAM BABU
Khata No	501
Plot No	2225
Village Name	Redma
Use	Residential
SubUse	Bungalow/ Dwelling / Non Apartment

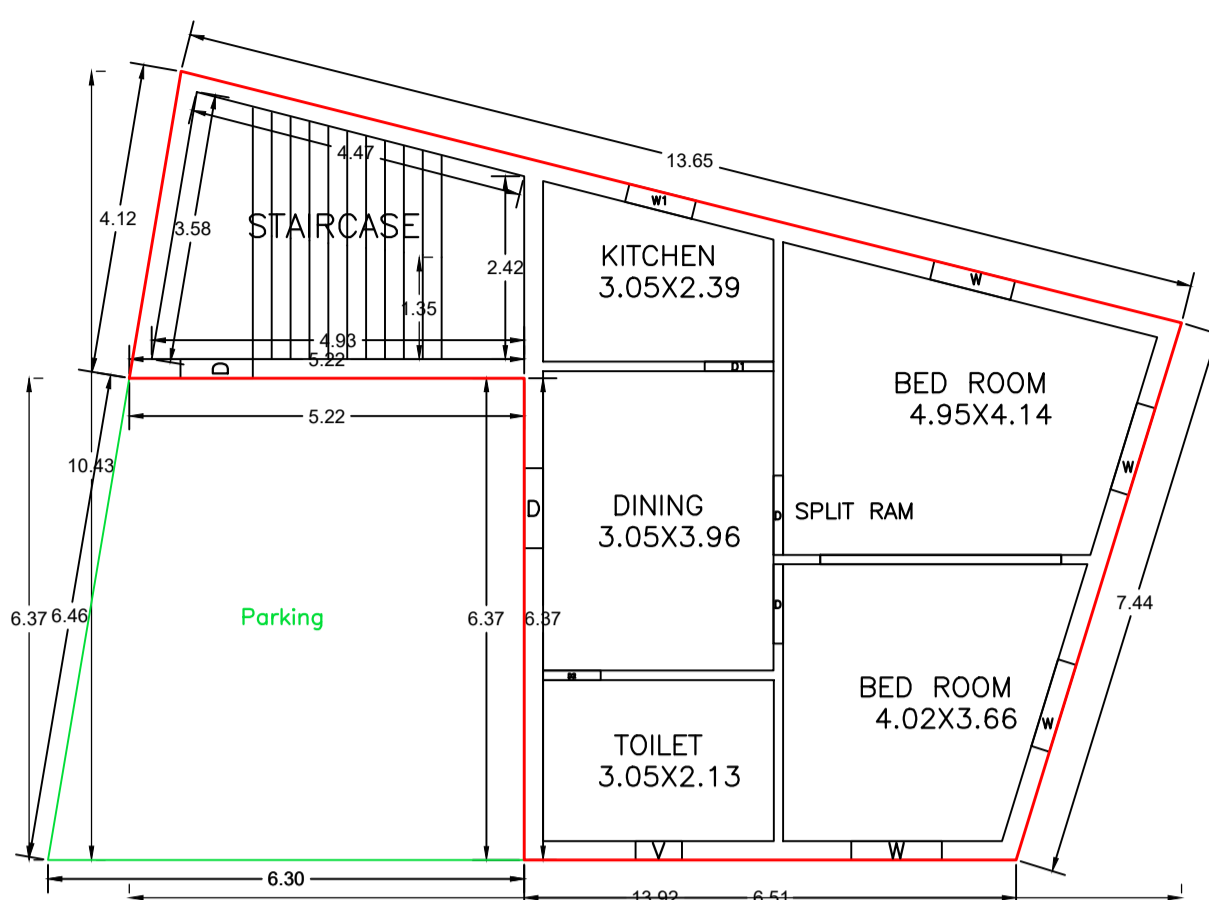

GROUND FLOOR PLAN (Proposed) (SCALE 1:100)

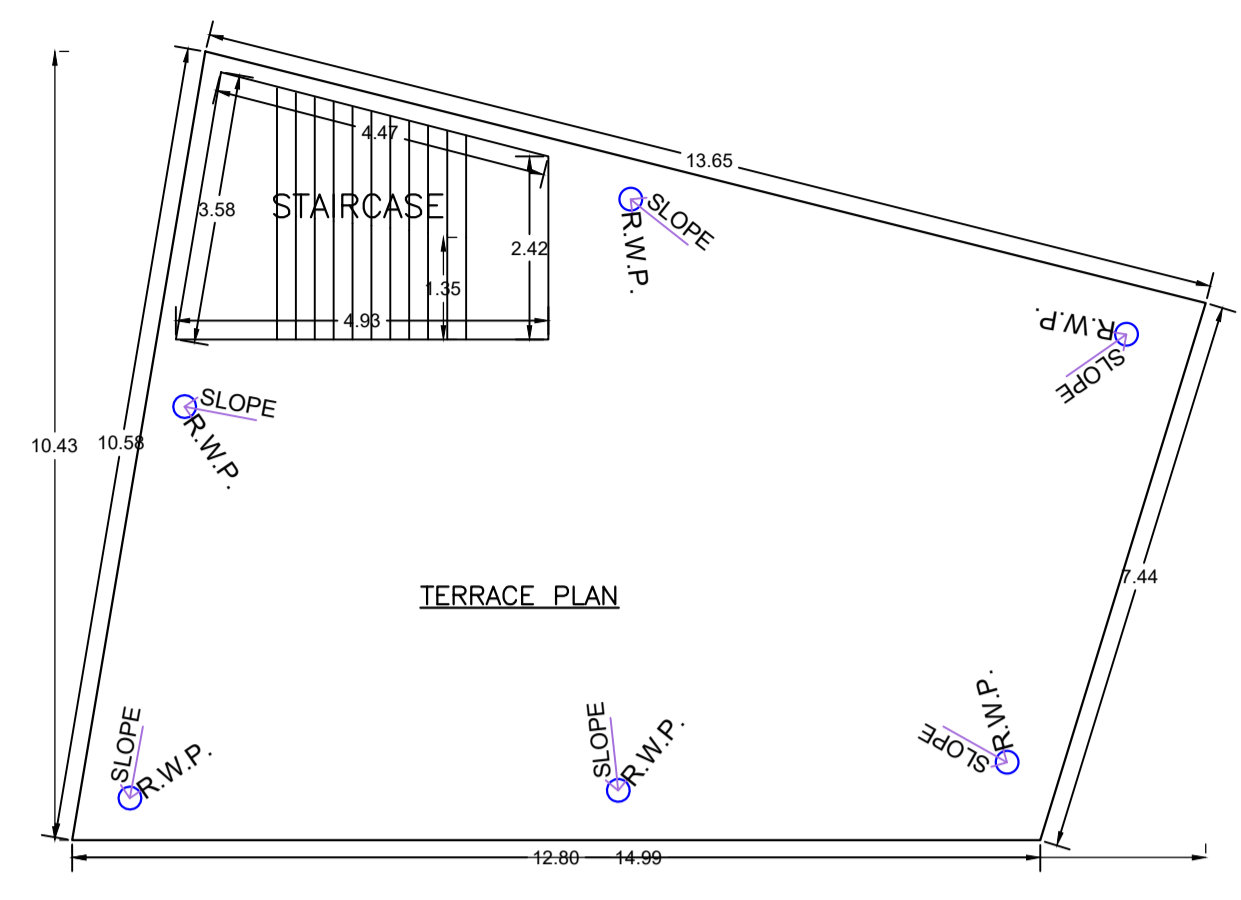

TERRACE FLOOR PLAN (SCALE 1:100)

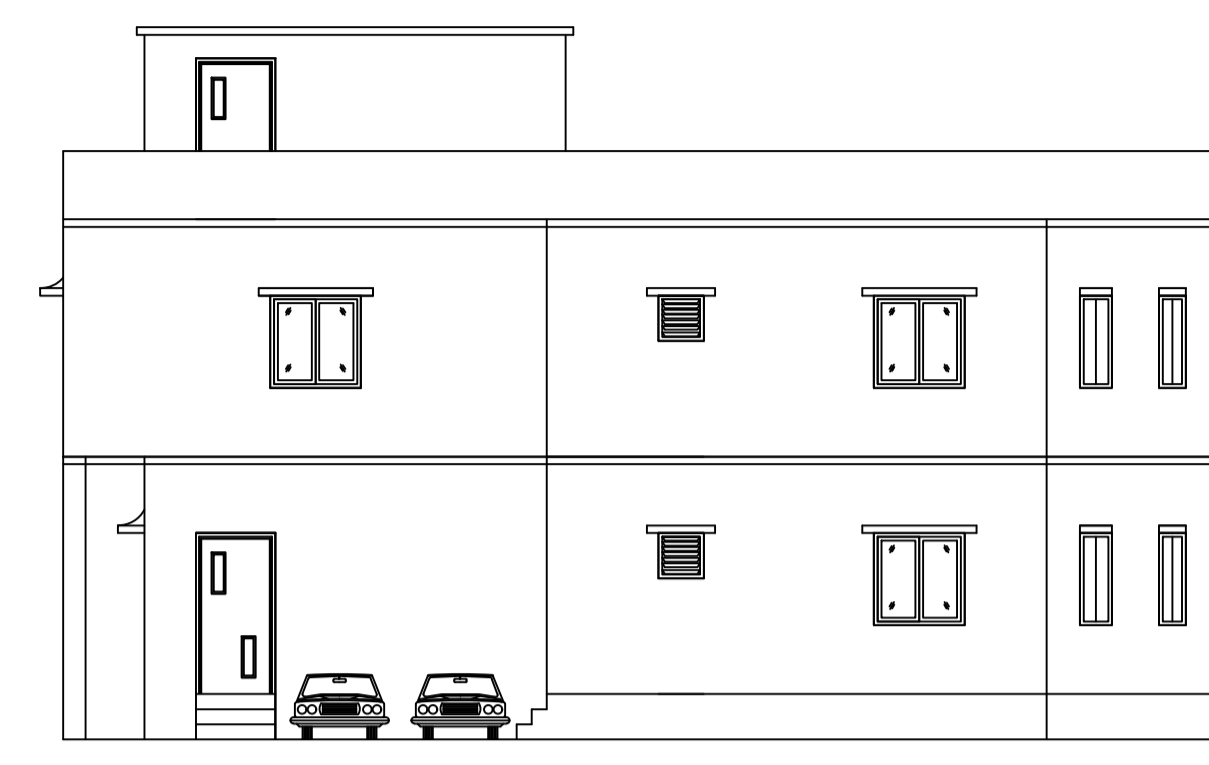

FRONT ELEVATION (SCALE 1:100)

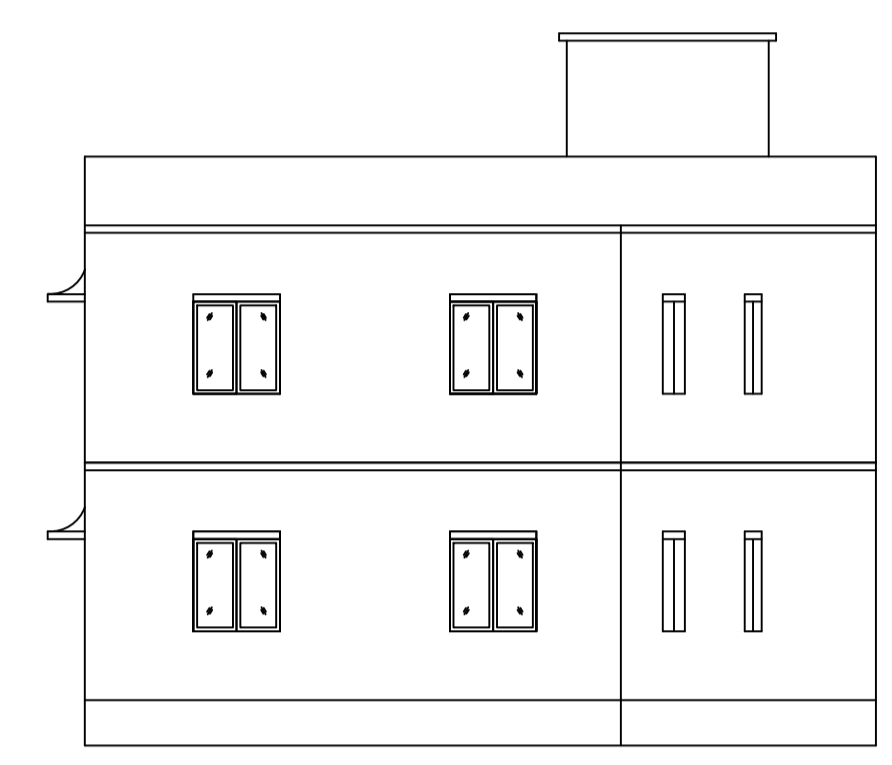

RIGHT SIDE ELEVATION (SCALE 1:100)

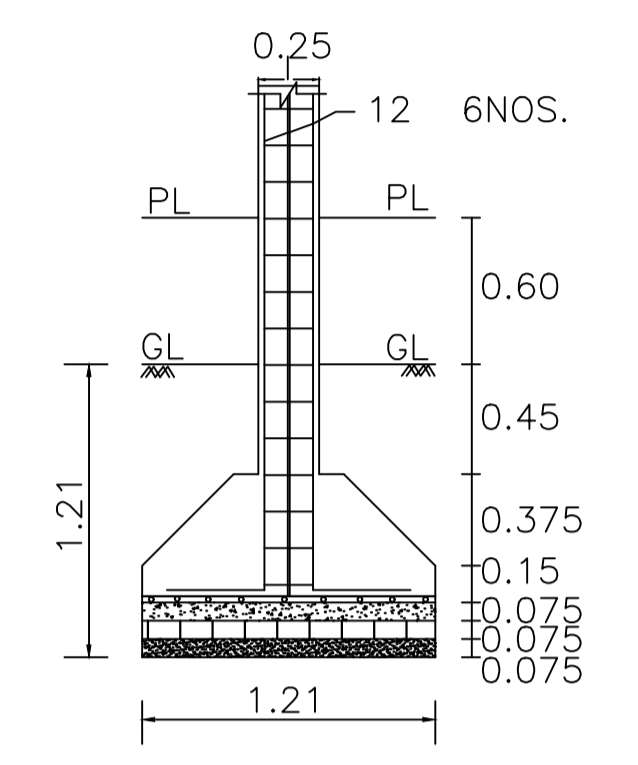

SECTION C-C (SCALE 1:100)

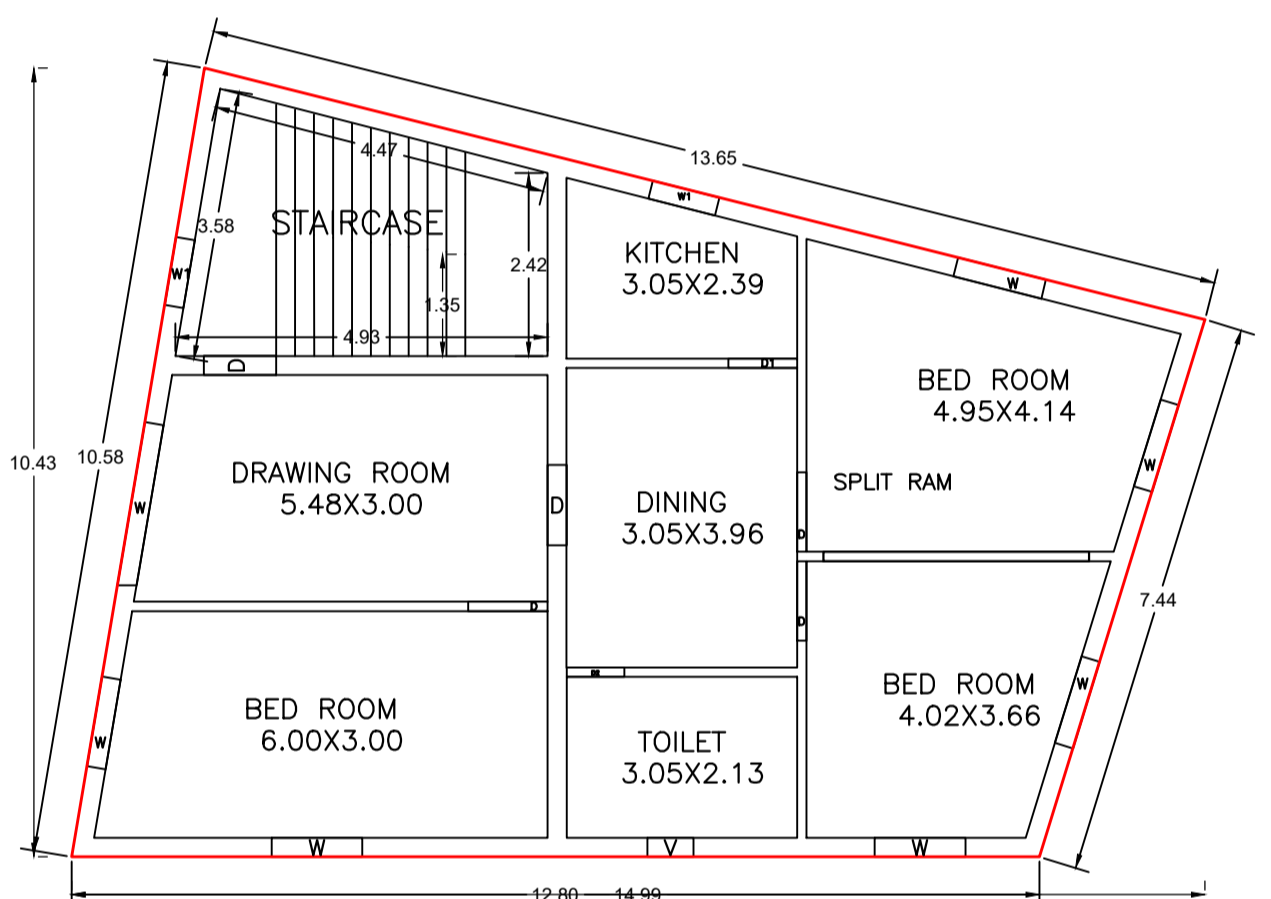

FIRST FLOOR PLAN (Proposed) (SCALE 1:100)

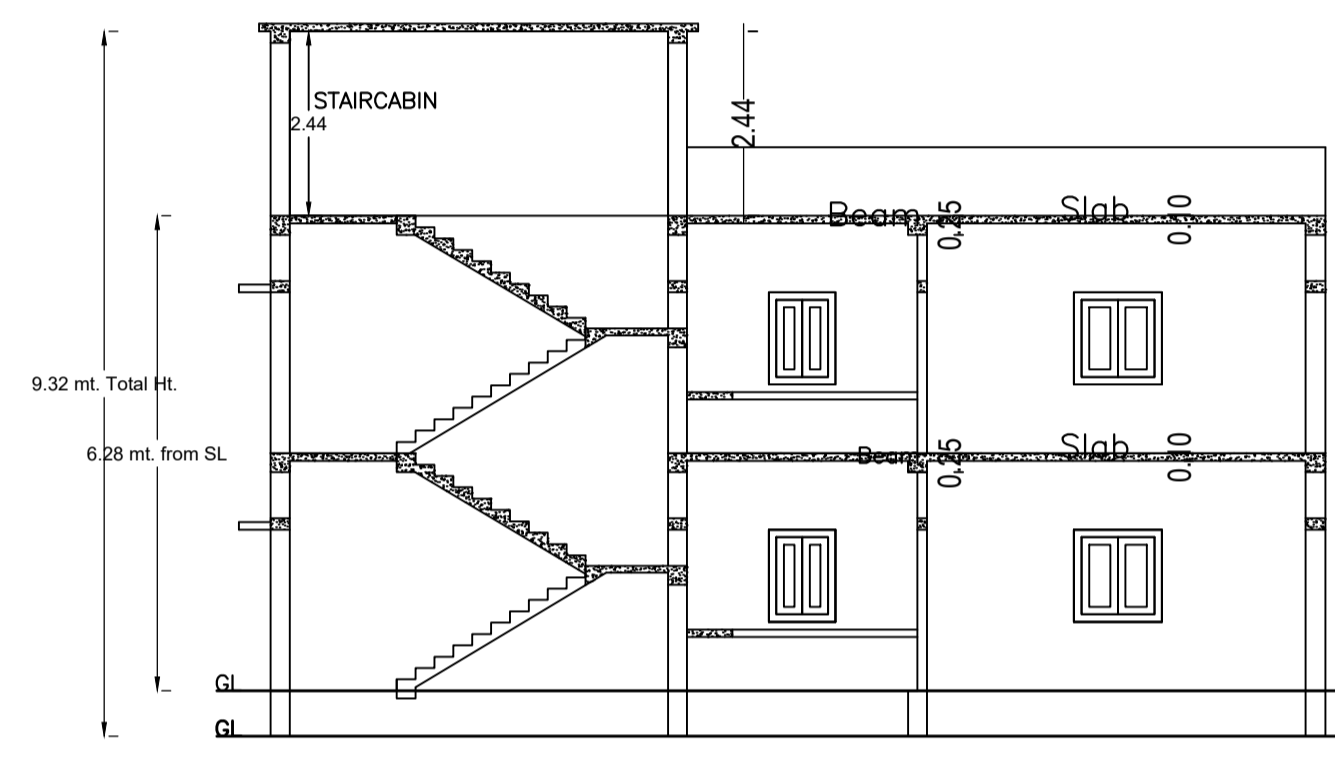

SECTION X-X' (SCALE 1:100)

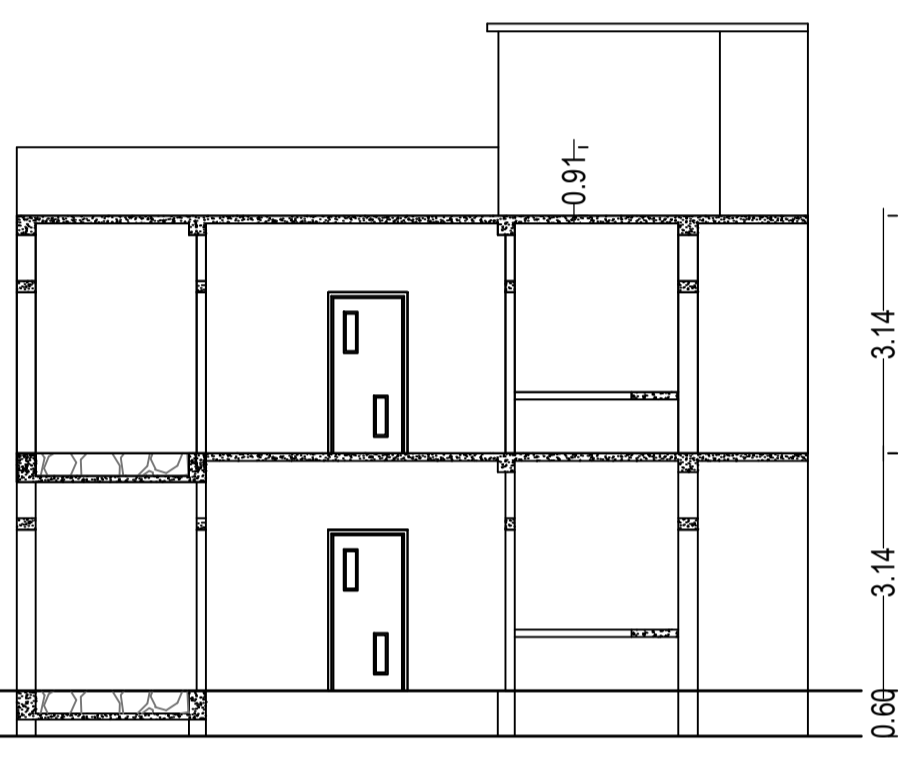

SECTION Y-Y' (SCALE 1:100)

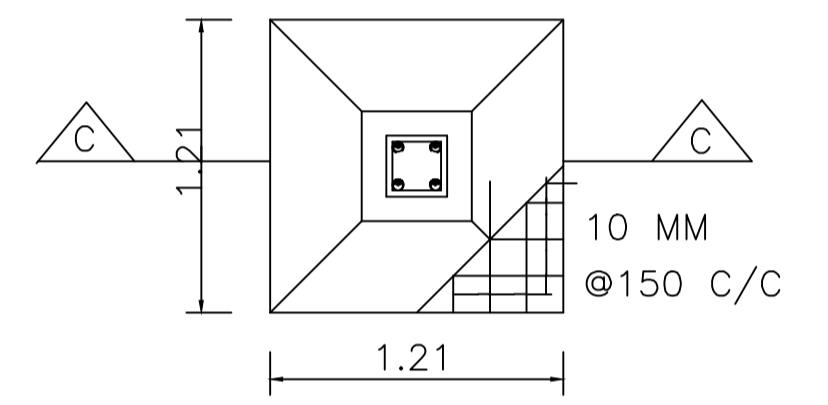

R.C.C.COLUMN FOUNDN. (SCALE- 1:50)

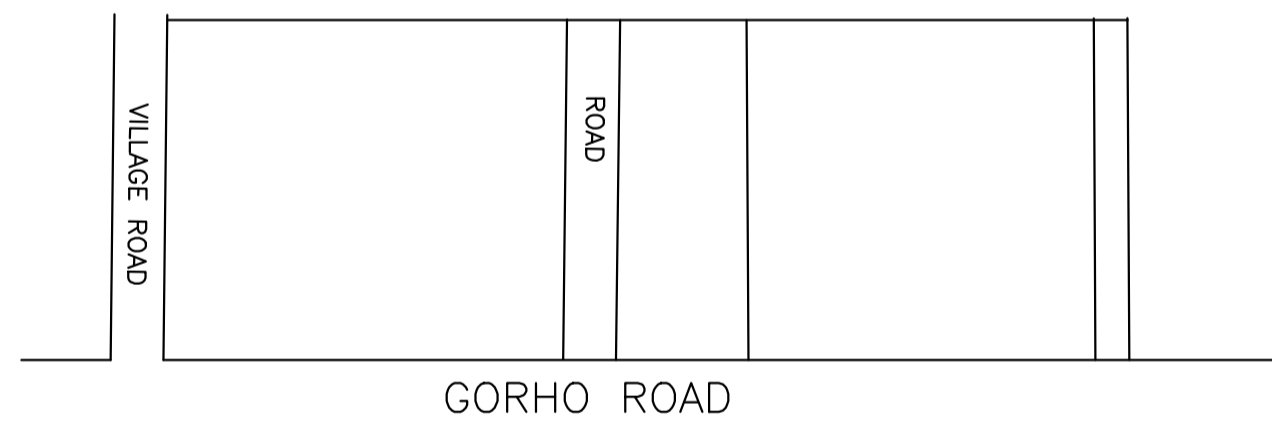

LOCATION PLAN (SCALE -NTS)

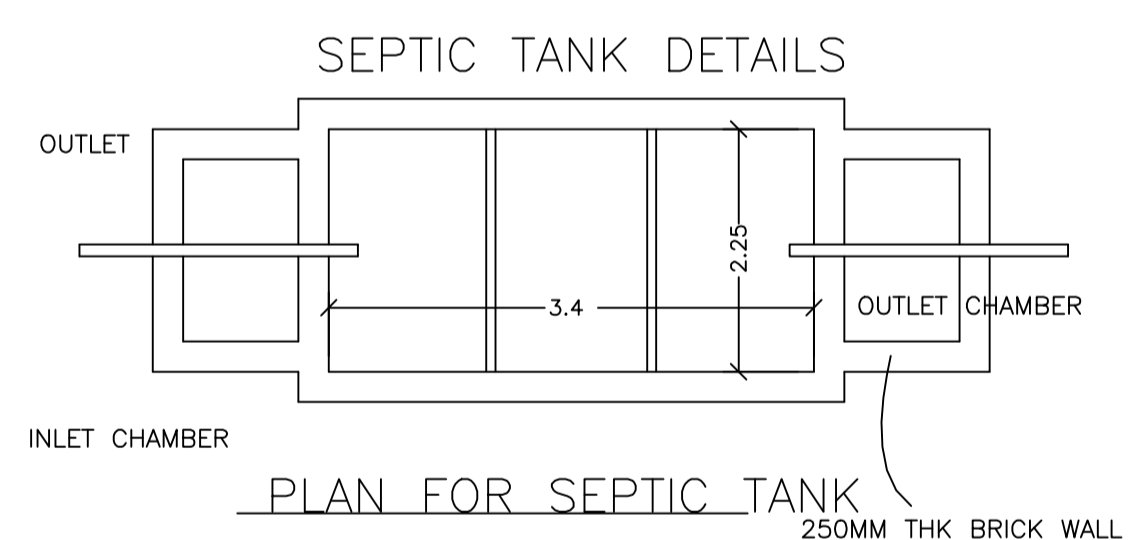

PLAN FOR SEPTIC TANK (SCALE 1:100)

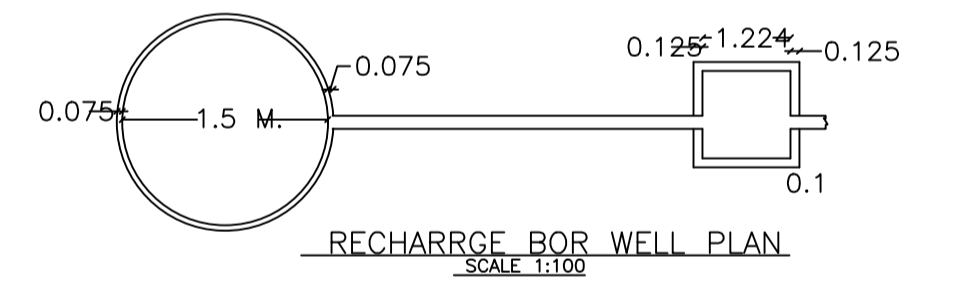

RECHARGE BOR WELL PLAN (SCALE 1:100)

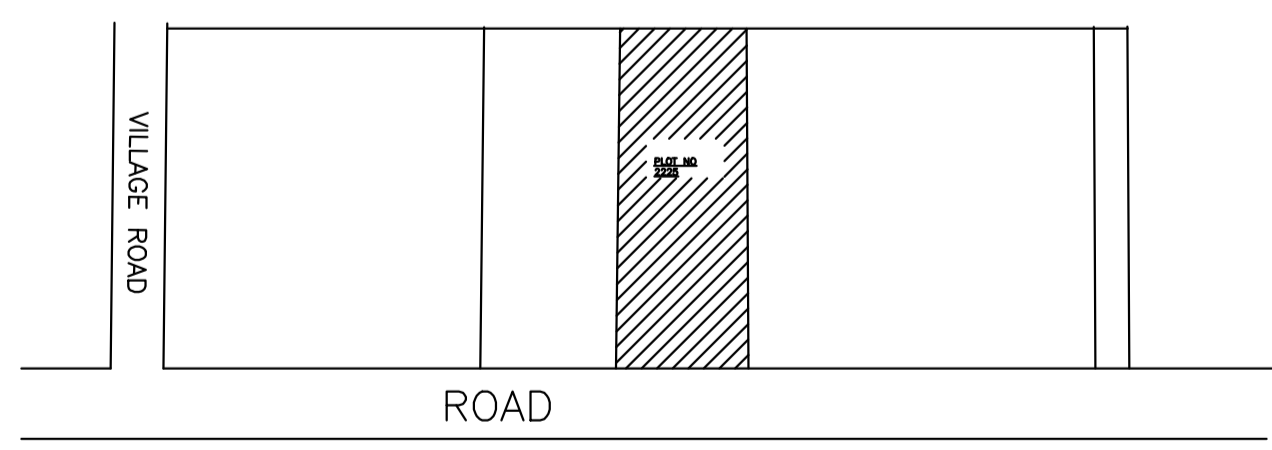

KEY PLAN (SCALE -NTS)

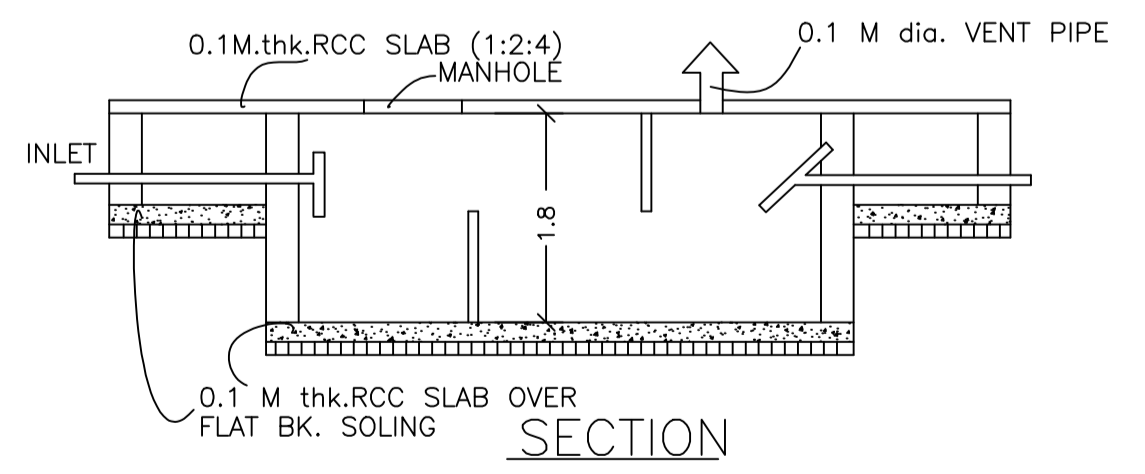

SECTION (SCALE 1:100)

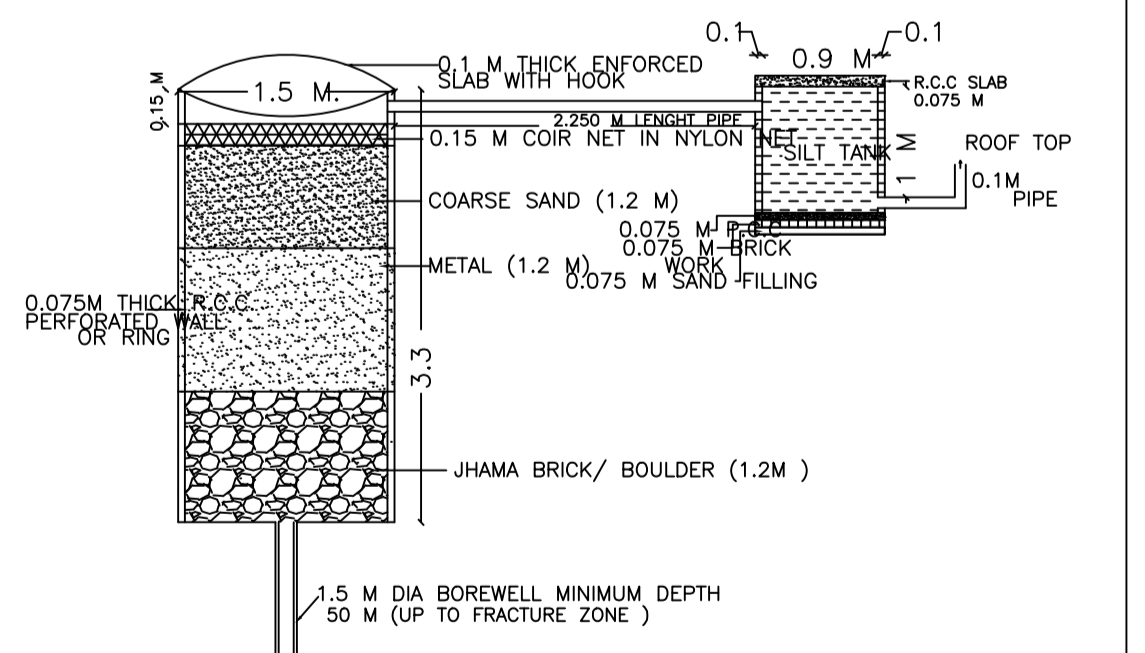

DETAILS OF GROUND WATER RECHARGING PIT WITH SILT TANK (SCALE 1:100)

SCHEDULE OF DOOR:

BUILDING NAME	NAME	LENGTH	HEIGHT	NOS
A (RAM B)	D2	0.76	2.10	02
A (RAM B)	D1	0.91	2.10	02
A (RAM B)	D	0.96	2.10	01
A (RAM B)	D	1.05	2.10	05
A (RAM B)	D	1.06	2.10	02

SCHEDULE OF WINDOW/VENTILATION:

BUILDING NAME	NAME	LENGTH	HEIGHT	NOS
A (RAM B)	V	0.61	0.60	02
A (RAM B)	W1	0.91	1.20	03
A (RAM B)	W	1.10	1.20	01
A (RAM B)	W	1.20	1.20	09
A (RAM B)	W	2.19	1.20	01

UnitBUA Table for Building :A (RAM B)

FLOOR	Name	UnitBUA Type	UnitBUA Area	Carpet Area	No. of Rooms	No. of Tenement
FIRST FLOOR PLAN	SPLIT RAM	FLAT	0.00	0.00	7	0
GROUND FLOOR PLAN	SPLIT RAM	FLAT	146.51	145.68	5	1
Total:	-	-	146.51	145.68	12	1

Building :A (RAM B)

Floor Name	Total Built Up Area (Sq.mt.)	Deductions (Area in Sq.mt.)		Proposed FAR Area (Sq.mt.)	Total FAR Area (Sq.mt.)	Total Consumed Additional FAR Area (Sq.mt.)	Trmt (No.)
		Parking	Resi.				
Ground Floor	117.44	36.71	80.73	80.73	80.73	01	
First Floor	117.44	0.00	117.44	117.44	117.44	00	
Terrace Floor	0.00	0.00	0.00	0.00	0.00	00	
Total :	234.88	36.71	198.17	198.17	198.17	01	
Total Number of Same Buildings :	1						
Total :	234.88	36.71	198.17	198.17	198.17	01	

LTP NAME AND SIGNATURE	STRUCTURAL ENG'S NAME AND SIGNATURE	BUILDER NAME AND SIGNATURE	DIGITAL SIGNATURE
MANORANJAN KUMAR SINGH MNNP/ENG/0003/2024			