

FAR & Tenement Details (Table 4c-1)

Building	No. of Same Bldg	Total Built Up Area (Sq.mt.)	Proposed FAR Area (Sq.mt.) Resi.	Total FAR Area (Sq.mt.)	Total Consumed Additional FAR Area (Sq.mt.)	Tnmt (No.)
A (BUILDING)	1	99.48	99.48	99.48	99.48	01
Grand Total :	1	99.48	99.48	99.48	99.48	01

Proposal Basic Information	
Proposal File No.	MNNP/BP/0163/W03/2024
Owner Name	Kumari Poonam Pathak
Khata No	25
Plot No	246
Village Name	Sudma Bariya
Use	Residential
SubUse	Bungalow Dwelling / Non Apartment

AREA STATEMENT		VERSION NO. : 1.0.70
MEDININAGAR MUNICIPAL CORPORATION		VERSION DATE: 16/10/2020
PROJECT DETAIL:		
Region: JHARKHAND URBAN LOCAL BODIES	Plot Use: Residential	
District: PALAMU	Plot SubUse: Bungalow Dwelling / Non Apartment	
Authority: MEDININAGAR MUNICIPAL CORPORATION	Plot/Nearby/Religious/Structure: NA	
Inward No: MNNP/BP/0163/W03/2024	Plot/SubPlot No: 246	
Application Type: General Proposal	North: -	
Project Type: Building Permission	South: -	
Nature of Development: New	East: -	
Location of Development Area: New Area	West: -	
AREA DETAILS:		
AREA OF PLOT (Minimum)	(A)	SQ.MT. 96.23
Deduction for NetPlot Area	Surrender Free of Cost	17.52
Total		17.52
NET AREA OF PLOT(Gross Plot Area - Deduction from Gross Plot area)	(A-Deductions)	78.71
Deduction for Balance Plot Area(from Gross Plot Area)		
Surrender Free of Cost		17.52
Common Plot		10.33
Total		27.85
BALANCE AREA OF PLOT(Net Plot Area - Recreational/Amenity space)	(A-Deductions)	68.38
PLOT AREA FOR COVERAGE(Net Plot Area)	(A-Deductions)	78.71
Plot Area for FAR (Net Plot Area + RoadWidening Area)	(A-Deductions)	96.23
COVERAGE CHECK		
Permissible Coverage area (70.00 %)		55.10
Proposed Coverage Area (63.19 %)		49.74
Total Prop. Coverage Area (63.19 %)		49.74
Balance coverage area (6.81 %)		5.36
FAR CHECK		
Perm. FAR Area (1,200)		115.48
Total Perm. FAR area		115.48
Residential FAR		99.49
Proposed FAR Area		99.49
Total Proposed FAR Area		99.49
Consumed FAR (Factor)		1.03
Balance FAR Area		15.99
BUILT UP AREA CHECK		
Total Proposed BuiltUp Area		99.48
ARCHITECT (Regd)	CHANDRA SHEKHAR THAKUR	
ENGINEER (Regd)		
SUPERVISOR (Regd)		
OWNER (Regd)	Kumari Poonam Pathak	
DEVELOPMENT AUTHORITY LOCAL BODY		

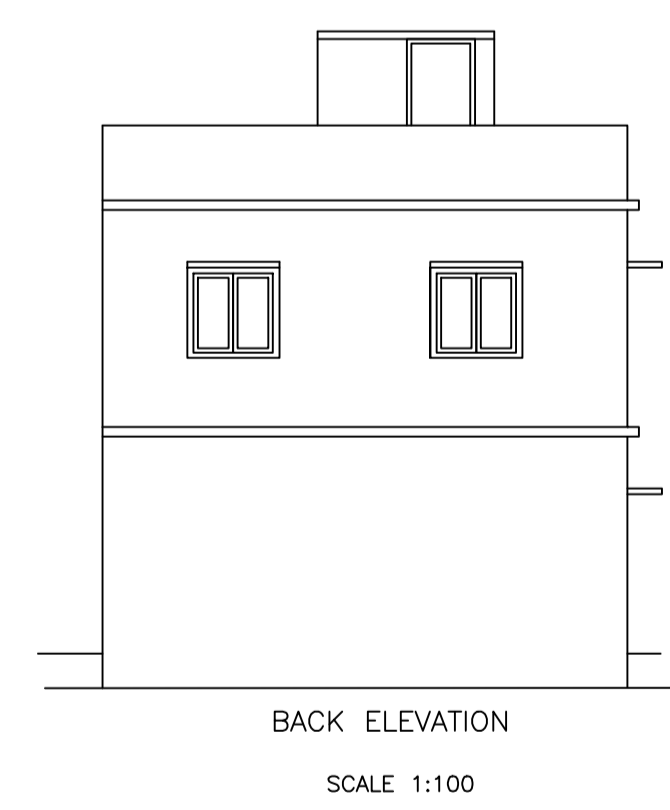
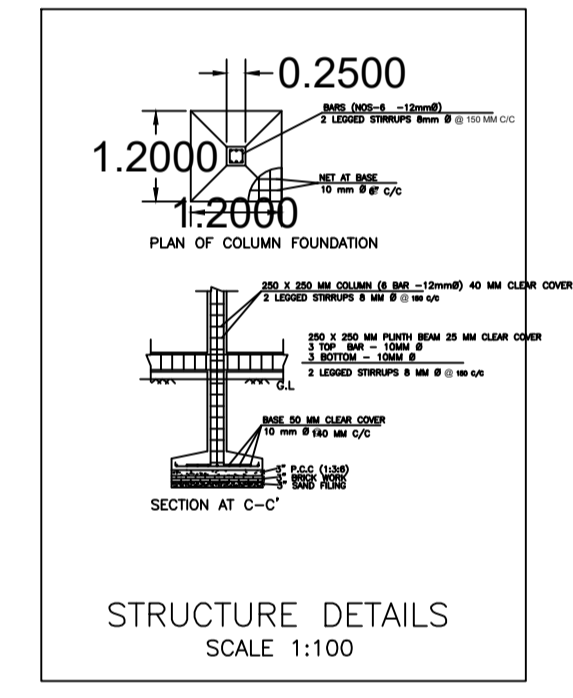
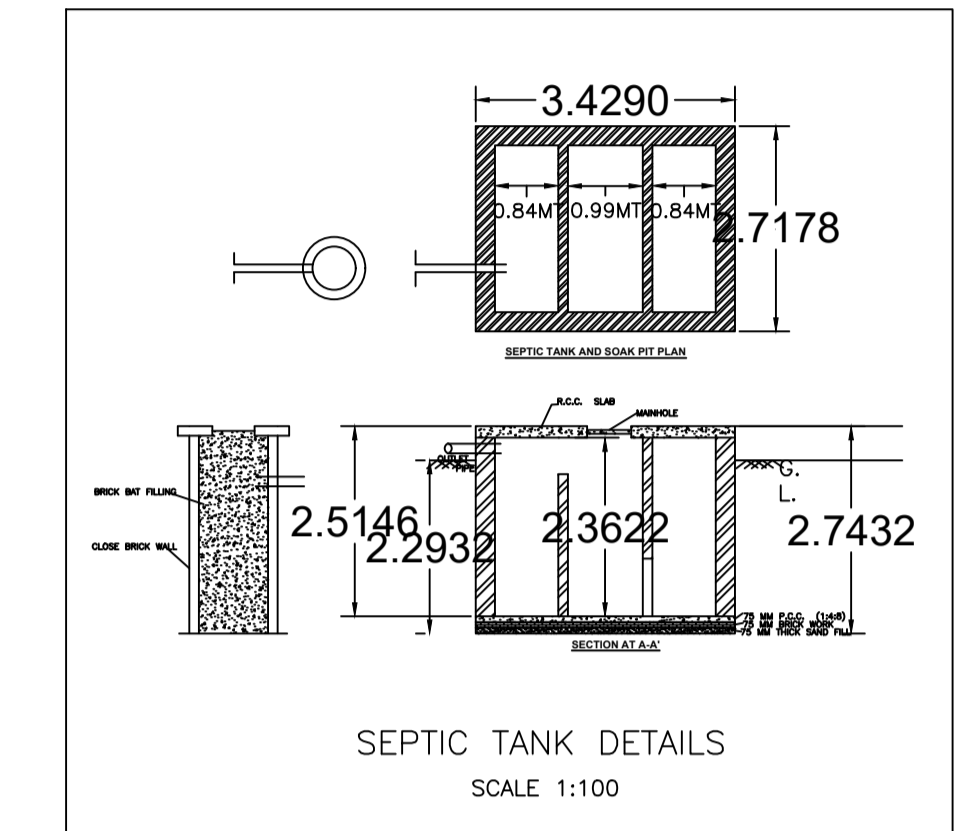
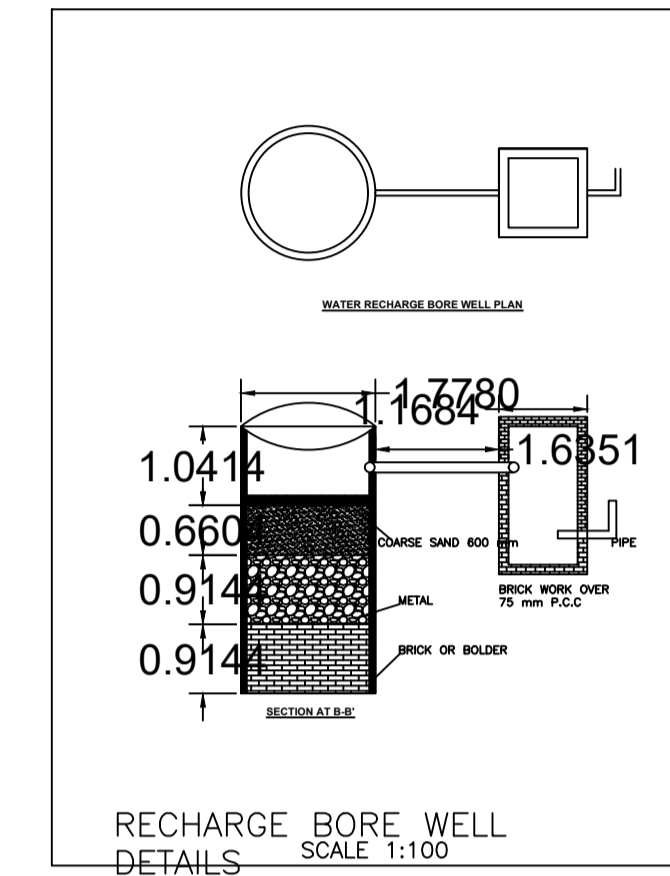
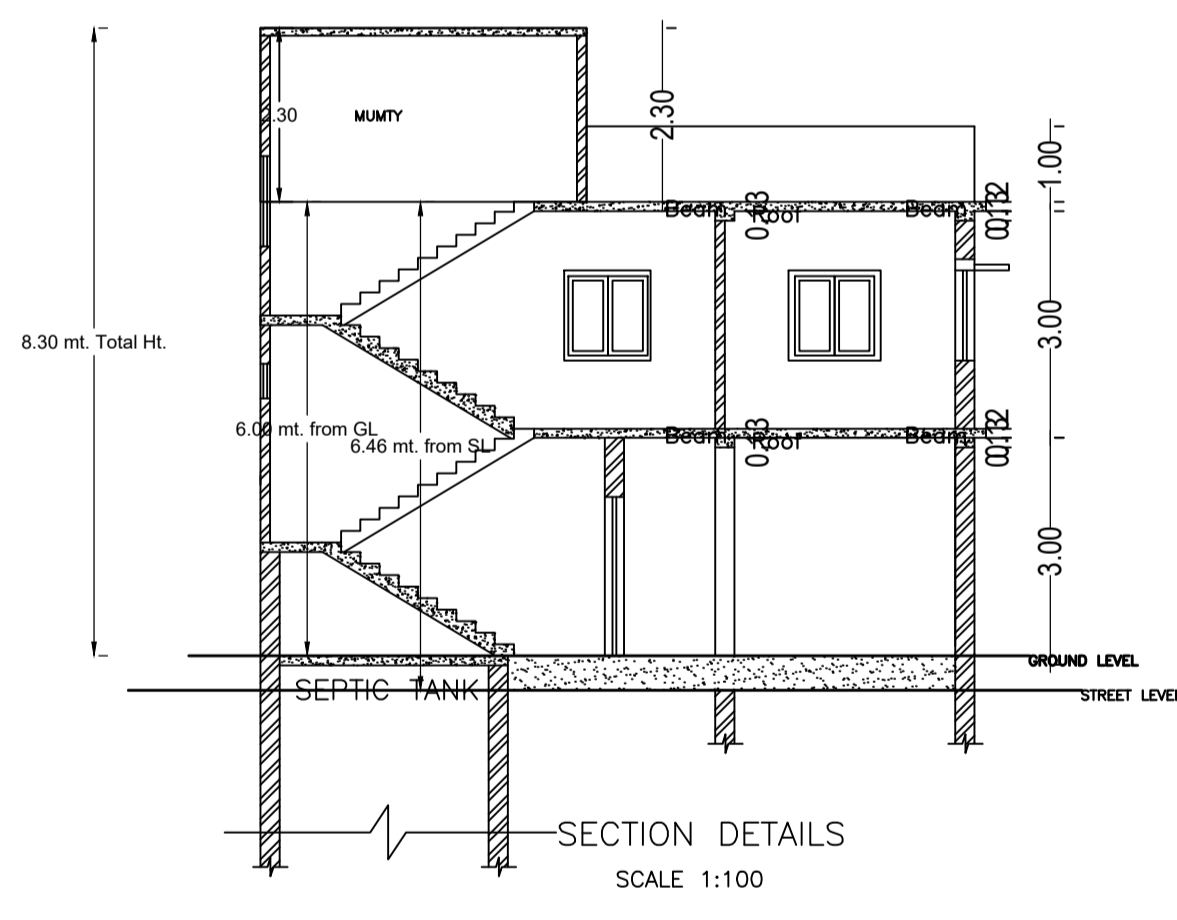
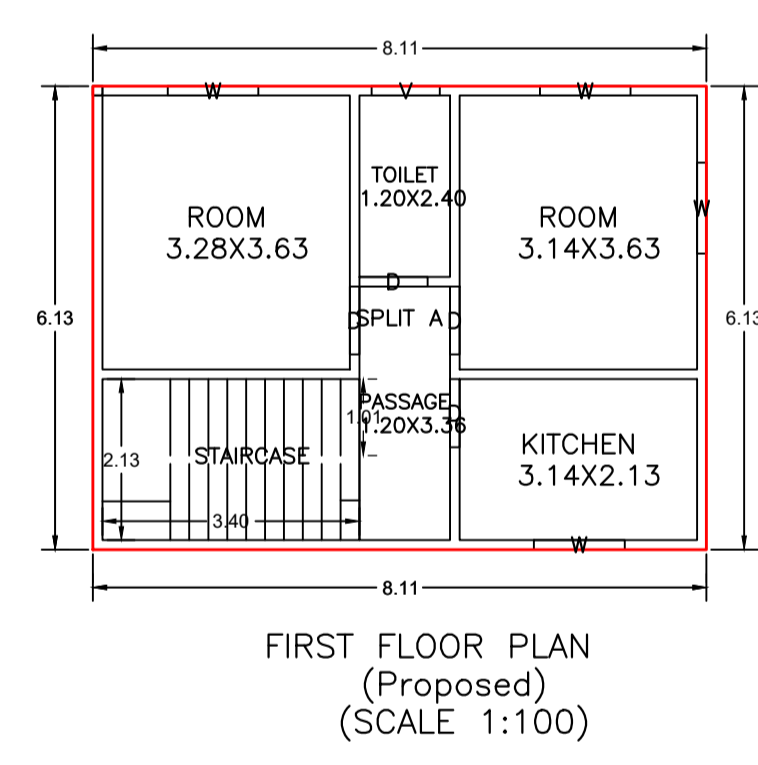
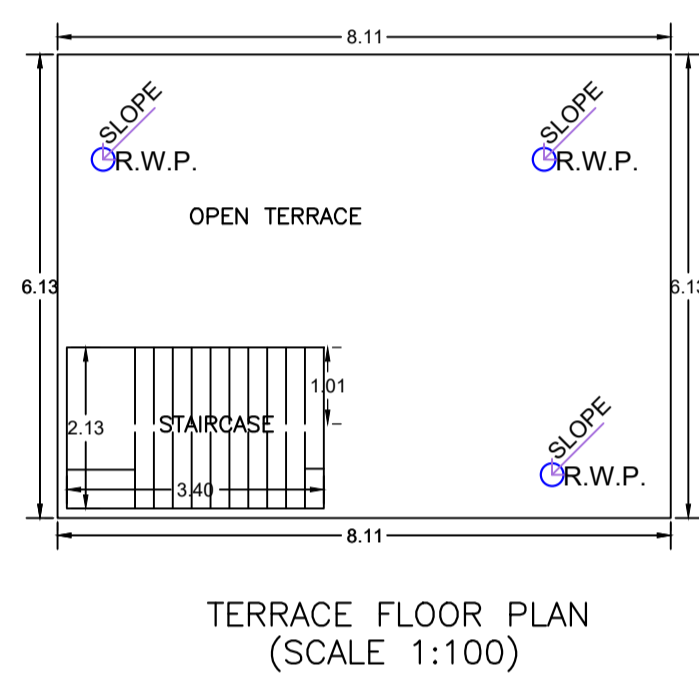
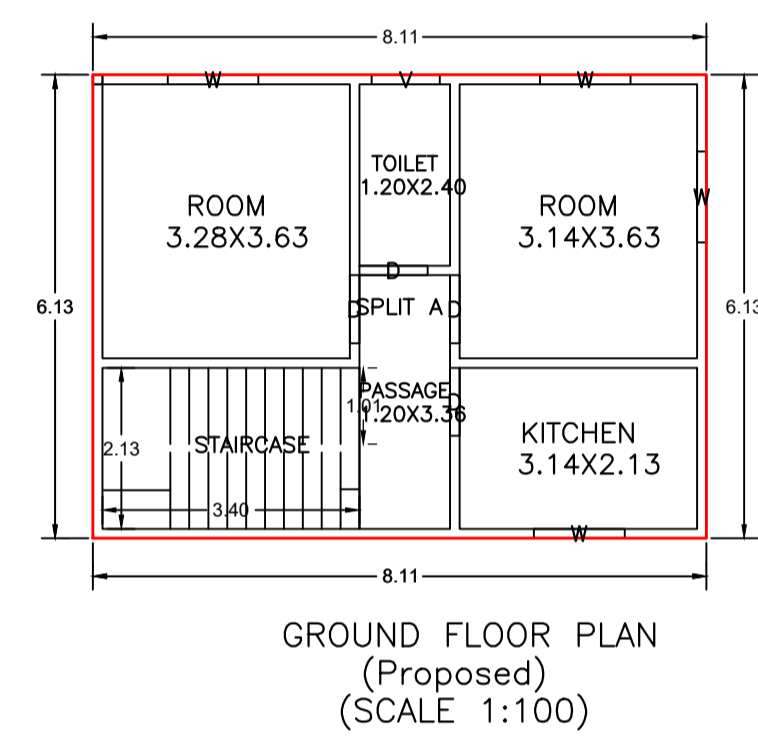

COLOR INDEX	
PLOT BOUNDARY	Black
ABUTTING ROAD	Red
PROPOSED CONSTRUCTION	Green
COMMON PLOT	Yellow
ROAD WIDENING AREA	Blue
EXISTING (To be retained)	Light Blue
EXISTING (To be demolished)	Dark Blue

Building :A (BUILDING)					
Floor Name	Total Built Up Area (Sq.mt.)	Proposed FAR Area (Sq.mt.) Resi.	Total FAR Area (Sq.mt.)	Total Consumed Additional FAR Area (Sq.mt.)	Tnmt (No.)
Ground Floor	49.74	49.74	49.74	49.74	01
First Floor	49.74	49.74	49.74	49.74	00
Terrace Floor	0.00	0.00	0.00	0.00	00
Total :	99.48	99.48	99.48	99.48	01
Total Number of Same Buildings :	1				
Total :	99.48	99.48	99.48	99.48	01

SCHEDULE OF DOOR:

BUILDING NAME	NAME	LENGTH	HEIGHT	NOS
A (BUILDING)	D	0.90	2.10	08

SCHEDULE OF WINDOW/VENTILATION:

BUILDING NAME	NAME	LENGTH	HEIGHT	NOS
A (BUILDING)	V	0.90	0.60	02
A (BUILDING)	W	1.20	1.20	08

UnitBUA Table for Building :A (BUILDING)

FLOOR	Name	UnitBUA Type	UnitBUA Area	Carpet Area	No. of Rooms	No. of Tenement
GROUND FLOOR PLAN	SPLIT A	FLAT	83.59	83.56	5	1
FIRST FLOOR PLAN	SPLIT A	FLAT	0.00	0.00	5	0
Total:	-	-	83.59	83.56	10	1

LTP NAME AND SIGNATURE	STRUCTURAL ENG'S NAME AND SIGNATURE	BUILDER NAME AND SIGNATURE	DIGITAL SIGNATURE
CHANDRA SHEKHAR THAKUR MNNP/ENG/004/2020			