

Proposal Basic Information	
Proposal File No.	MNNP/BP/0153/W17/2024
Owner Name	LATA SINGH
Khata No	131
Plot No	358
Village Name	Redma
Use	Residential
SubUse	Bungalow Dwelling / Non Apartment

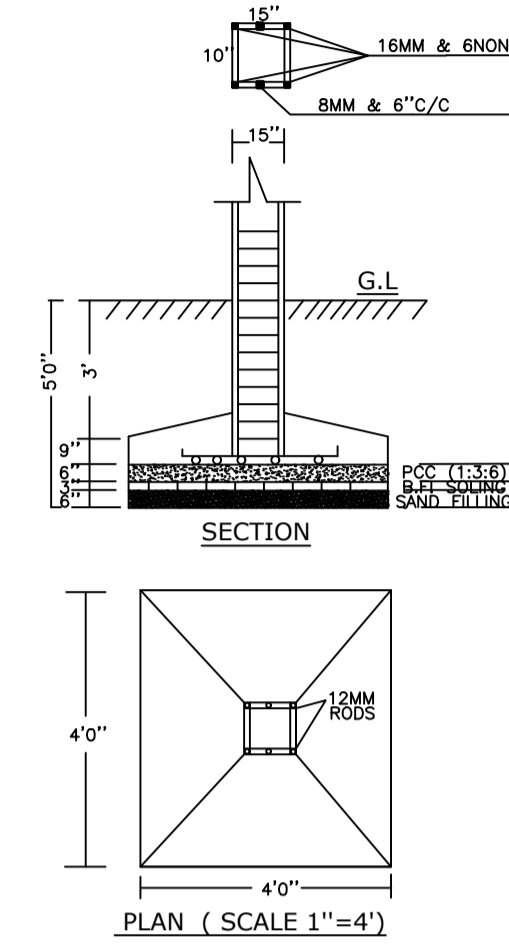
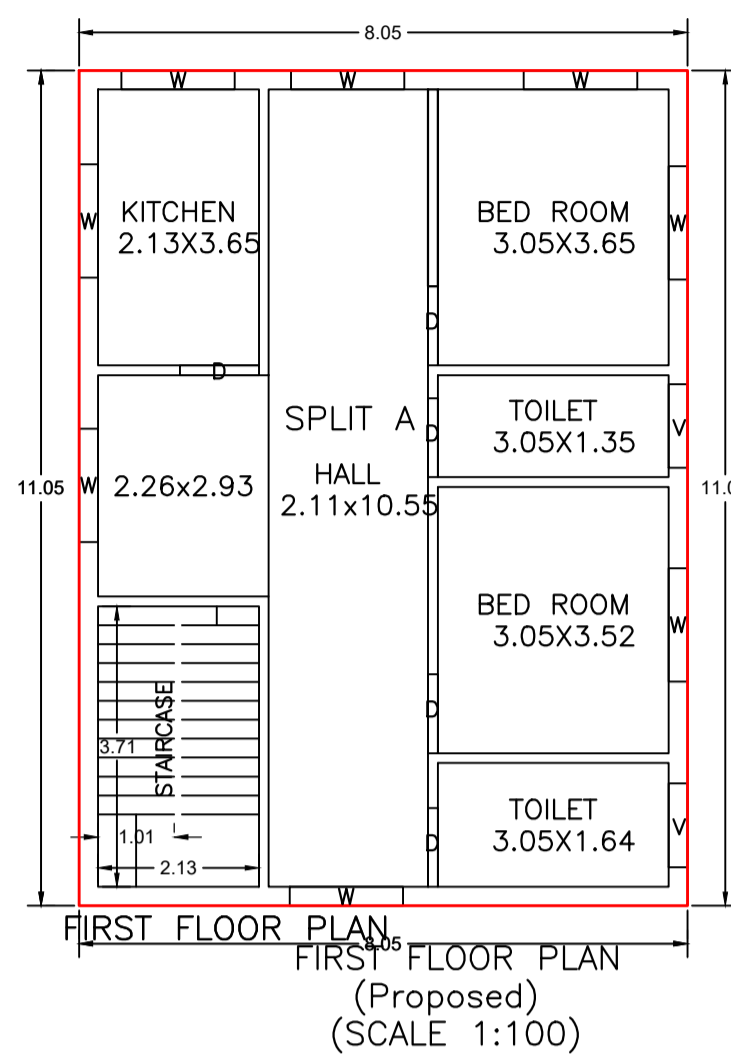
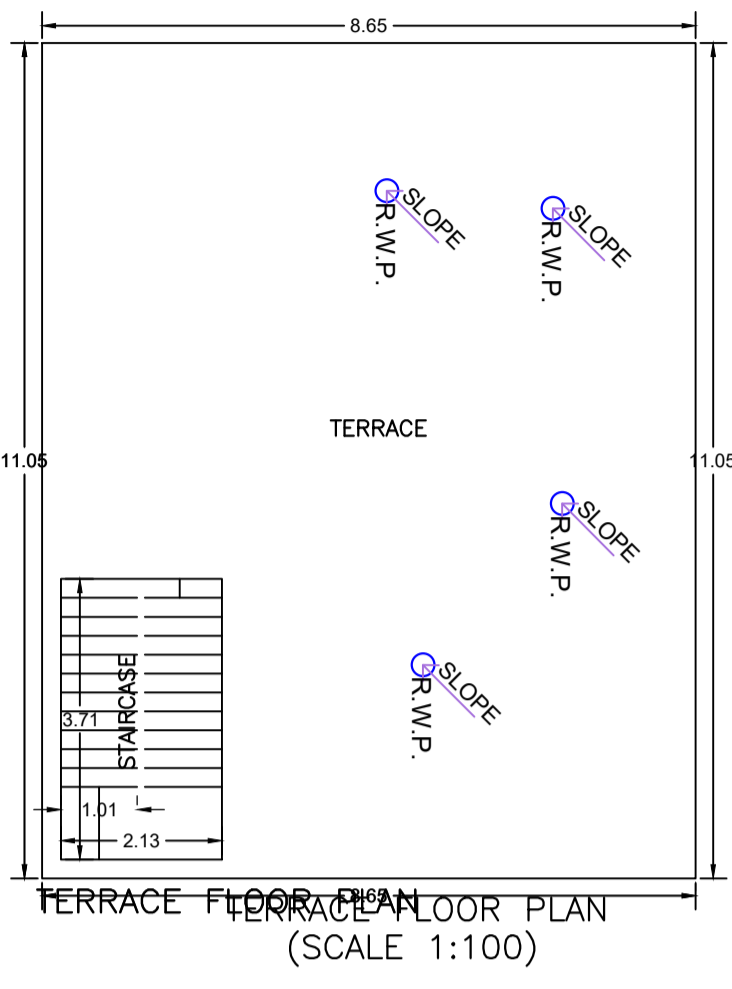
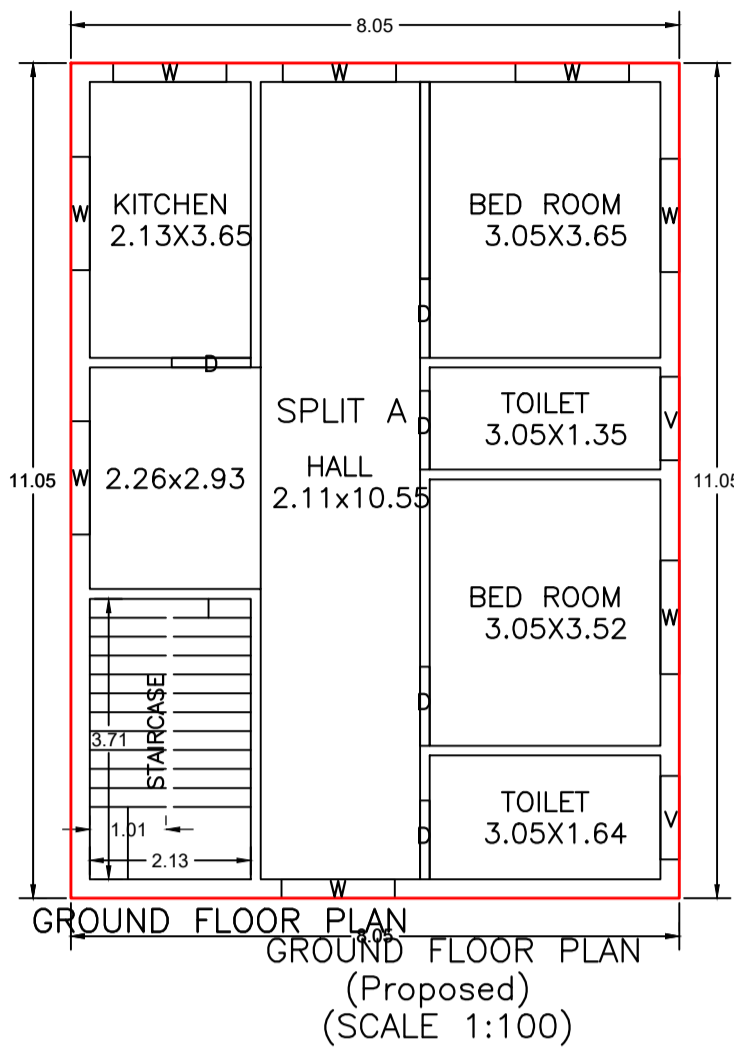
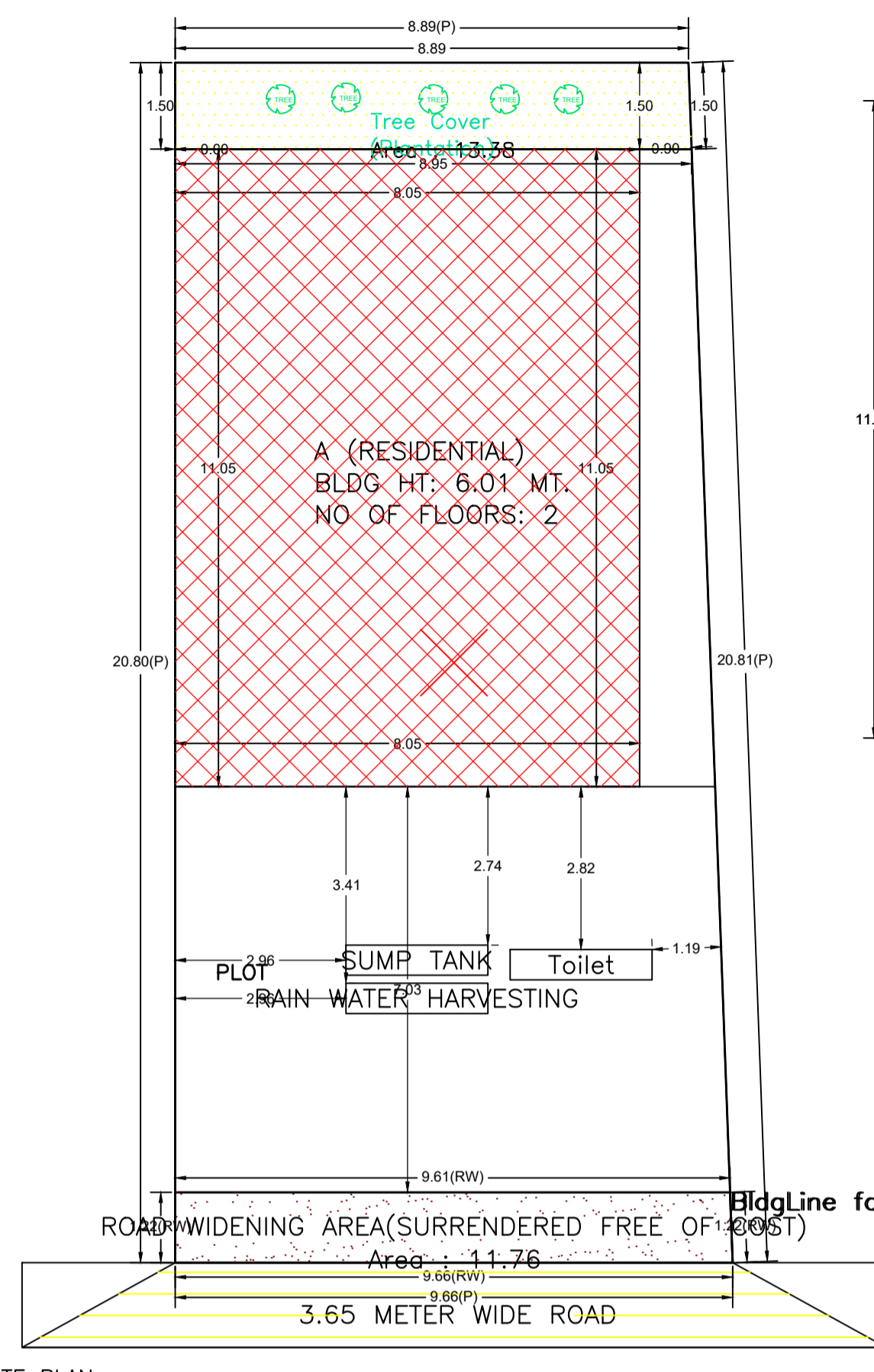

Building :A (RESIDENTIAL)

Floor Name	Total Built Up Area (Sq.mt.)	Proposed FAR Area (Sq.mt.) Resi.	Total FAR Area (Sq.mt.)	Total Consumed Additional FAR Area (Sq.mt.)	Tnmt (No.)
Ground Floor	88.92	88.92	88.92	88.92	01
First Floor	88.92	88.92	88.92	88.92	00
Terrace Floor	0.00	0.00	0.00	0.00	00
Total :	177.84	177.84	177.84	177.84	01
Total Number of Same Buildings :	1				
Total :	177.84	177.84	177.84	177.84	01

SCHEDULE OF DOOR:

BUILDING NAME	NAME	LENGTH	HEIGHT	NOS
A (RESIDENTIAL)	D	1.04	2.10	10

SCHEDULE OF WINDOW/VENTILATION:

BUILDING NAME	NAME	LENGTH	HEIGHT	NOS
A (RESIDENTIAL)	V	1.11	1.20	04
A (RESIDENTIAL)	W	1.50	1.20	16

UnitBUA Table for Building :A (RESIDENTIAL)

FLOOR	Name	UnitBUA Type	UnitBUA Area	Carpet Area	No. of Rooms	No. of Tenement
GROUND FLOOR PLAN	SPLIT A	FLAT	158.99	158.32	6	1
FIRST FLOOR PLAN	SPLIT A	FLAT	0.00	0.00	6	0
Total:	-	-	158.99	158.32	12	1

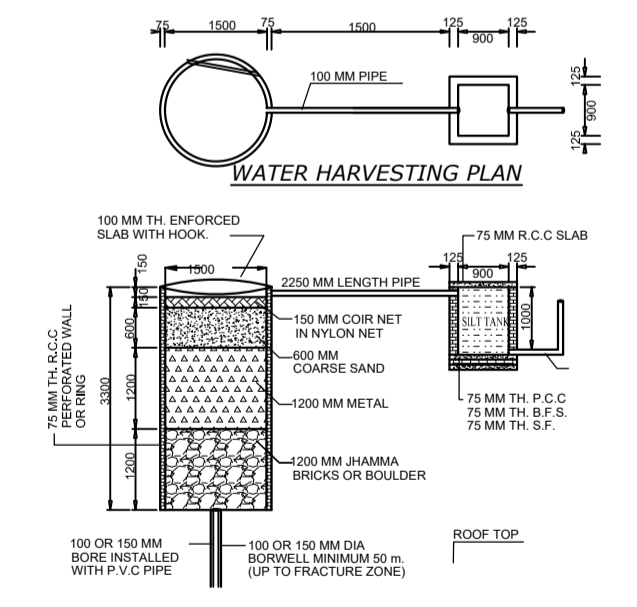
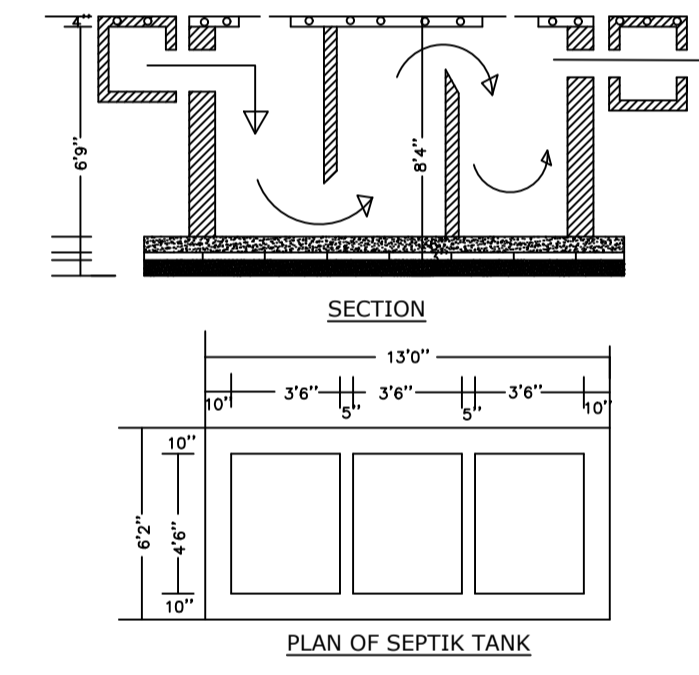
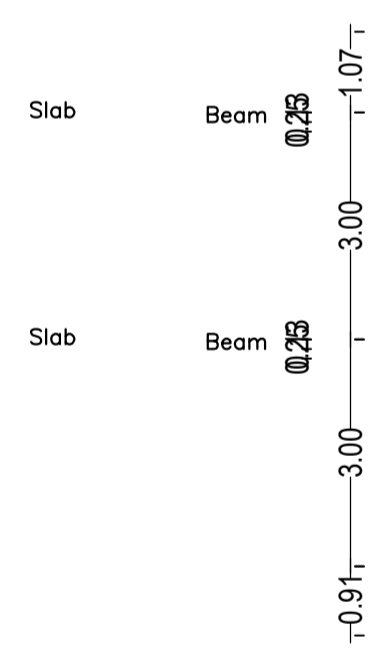
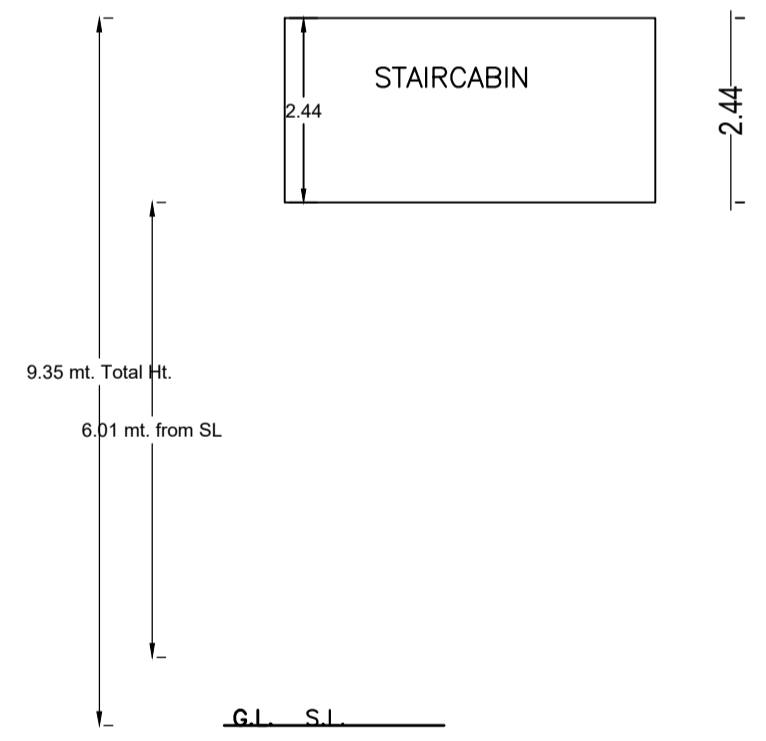

AREA STATEMENT		VERSION NO. : 1.0.70
MEDININAGAR MUNICIPAL CORPORATION		VERSION DATE: 16/10/2020
PROJECT DETAIL:		
Region : JHARKHAND URBAN LOCAL BODIES	Plot Use: Residential	
District: PALAMU	Plot SubUse: Bungalow Dwelling / Non Apartment	
Authority: MEDININAGAR MUNICIPAL CORPORATION	Plot/Nearby/Religious/Structure: NA	
Inward No. MNNP/BP/0153/W17/2024	Plot/SubPlot No: 358	
Application Type: General Proposal	North: -	
Project Type: Building Permission	South: -	
Nature of Development: New	East: -	
Location of Development Area: New Area	West: -	
AREA DETAILS:		
AREA OF PLOT (Minimum)	(A)	SQ.MT.
Deduction for NetPlot Area		
Surrender Free of Cost		11.76
Total		11.76
NET AREA OF PLOT(Gross Plot Area - Deduction from Gross Plot area)	(A-Deductions)	181.18
Deduction for Balance Plot Area(from Gross Plot Area)		
Surrender Free of Cost		11.76
Common Plot		13.38
Total		25.14
BALANCE AREA OF PLOT(Net Plot Area - Recreational/Amenity space)	(A-Deductions)	167.80
PLOT AREA FOR COVERAGE(Net Plot Area)	(A-Deductions)	181.18
Plot Area for FAR (Net Plot Area + RoadWidening Area)	(A-Deductions)	192.94
COVERAGE CHECK		
Permissible Coverage area ( 70.00 % )		126.83
Proposed Coverage Area ( 49.08 % )		88.92
Total Prop. Coverage Area ( 49.08 % )		88.92
Balance coverage area ( 20.92 % )		37.91
FAR CHECK		
Perm. FAR Area ( 1.500 )		289.41
Total Perm. FAR area		289.41
Residential FAR		177.84
Proposed FAR Area		177.84
Total Proposed FAR Area		177.84
Consumed FAR (Factor)		0.92
Balance FAR Area		111.57
BUILT UP AREA CHECK		
Total Proposed BuiltUp Area		177.84
ARCHITECT (Regd)		
ENGINEER (Regd)		Umesh Prasad
SUPERVISOR (Regd)		
OWNER (Regd)		LATA SINGH
DEVELOPMENT AUTHORITY		
		LOCAL BODY

COLOR INDEX	
PLOT BOUNDARY	Black
ABUTTING ROAD	Green
PROPOSED CONSTRUCTION	Red
COMMON PLOT	Yellow
ROAD WIDENING AREA	Orange
EXISTING (To be retained)	Blue
EXISTING (To be demolished)	White

Floor Name	Building Name A (RESIDENTIAL)		Total	
	Proposed Built Up Area (Sq.mt.)	Proposed FAR Area (Sq.mt.)	Total Proposed Built Up Area (Sq.mt.)	Total FAR Area (Sq.mt.)
Ground Floor	88.92	88.92	88.92	88.92
First Floor	88.92	88.92	88.92	88.92
Terrace Floor	0.00	0.00	0.00	0.00
Total :	177.84	177.84	177.84	177.84

Building Name	Building Use	Building SubUse	Building Structure
A (RESIDENTIAL)	Residential	Bungalow Dwelling / Non Apartment	Non-Highrise

Building	No. of Same Bldg	Total Built Up Area (Sq.mt.)	Proposed FAR Area (Sq.mt.) Resi.	Total FAR Area (Sq.mt.)	Total Consumed Additional FAR Area (Sq.mt.)	Tnmt (No.)
A (RESIDENTIAL)	1	177.84	177.84	177.84	177.84	01
Grand Total :	1	177.84	177.84	177.84	177.84	01

LTP NAME AND SIGNATURE	STRUCTURAL ENG'S NAME AND SIGNATURE	BUILDER NAME AND SIGNATURE	DIGITAL SIGNATURE
Umesh Prasad MNNP/ENG/0002/2024			