

Proposal Basic Information

Proposal File No.	MNNP/BP/0165/W06/2024
Owner Name	Sanjay Kumar Singh
Khata No	320
Plot No	1679
Village Name	Baralota
Use	Residential
SubUse	Bungalow Dwelling / Non Apartment

FAR & Tenement Details (Table 4c-1)

Building	No. of Same Bldg	Total Built Up Area (Sq.mt.)	Proposed FAR Area (Sq.mt.) Resi.	Total FAR Area (Sq.mt.)	Total Consumed Additional FAR Area (Sq.mt.)	Tnmt (No.)
A (BUILDING)	1	91.10	91.10	91.10	91.10	01
Grand Total :	1	91.10	91.10	91.10	91.10	01

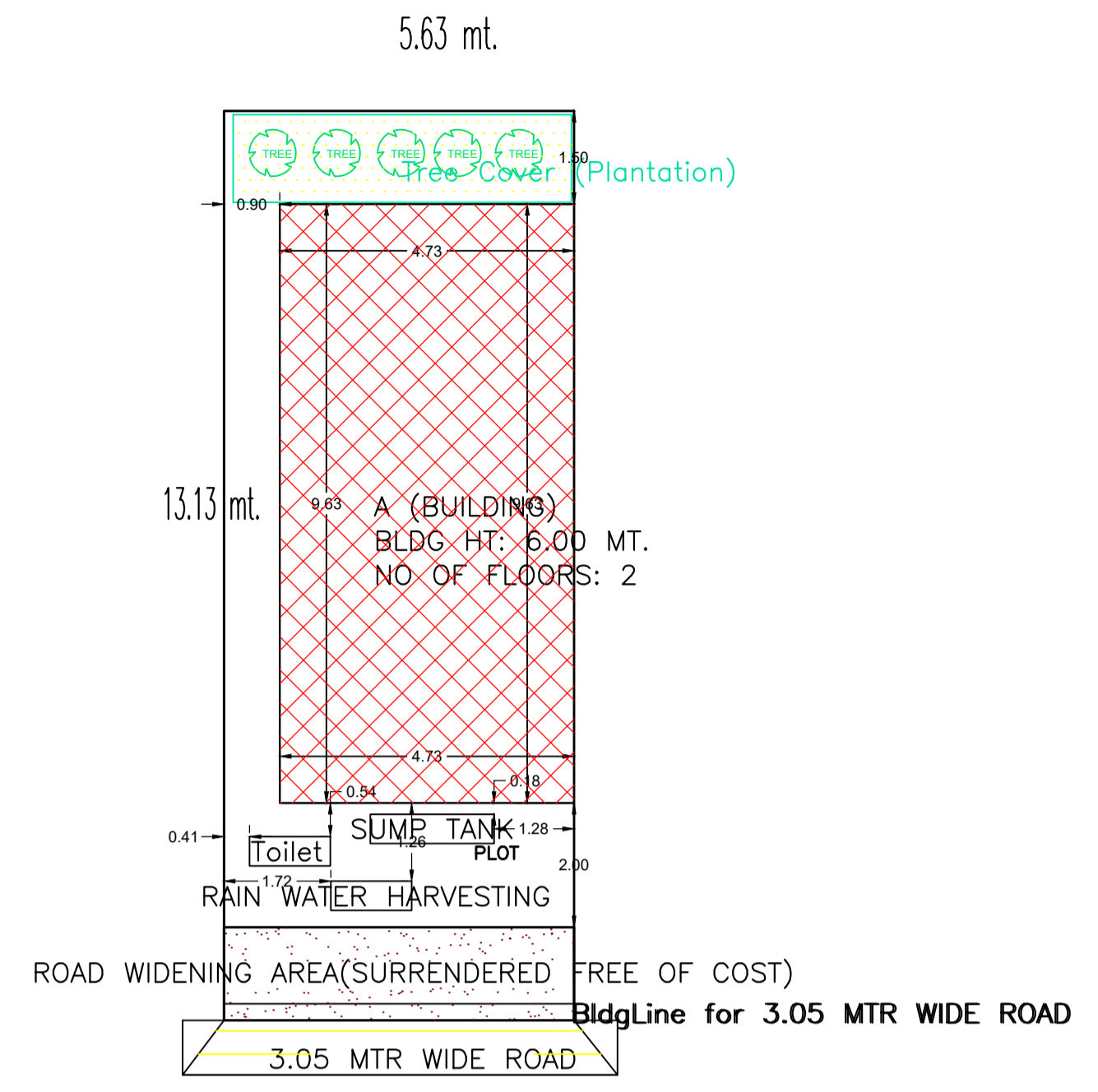

SITE PLAN

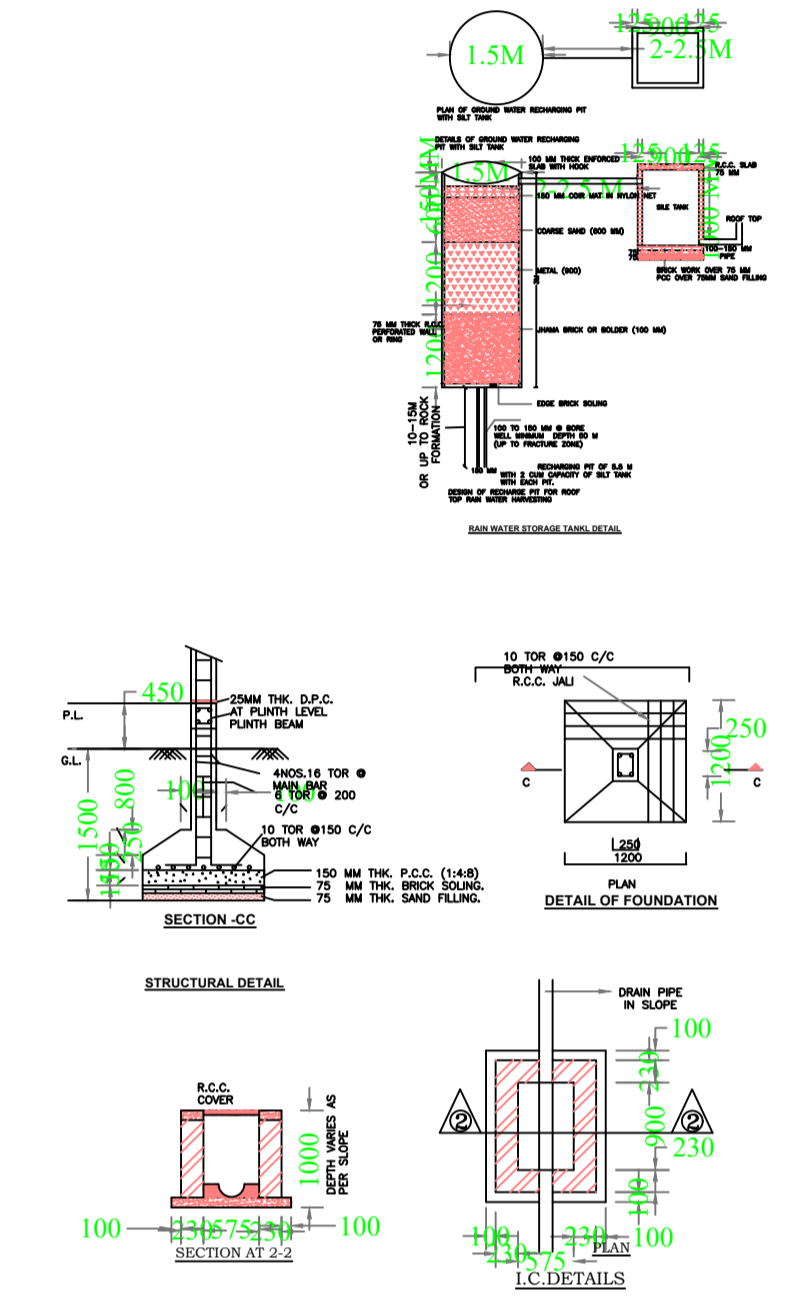
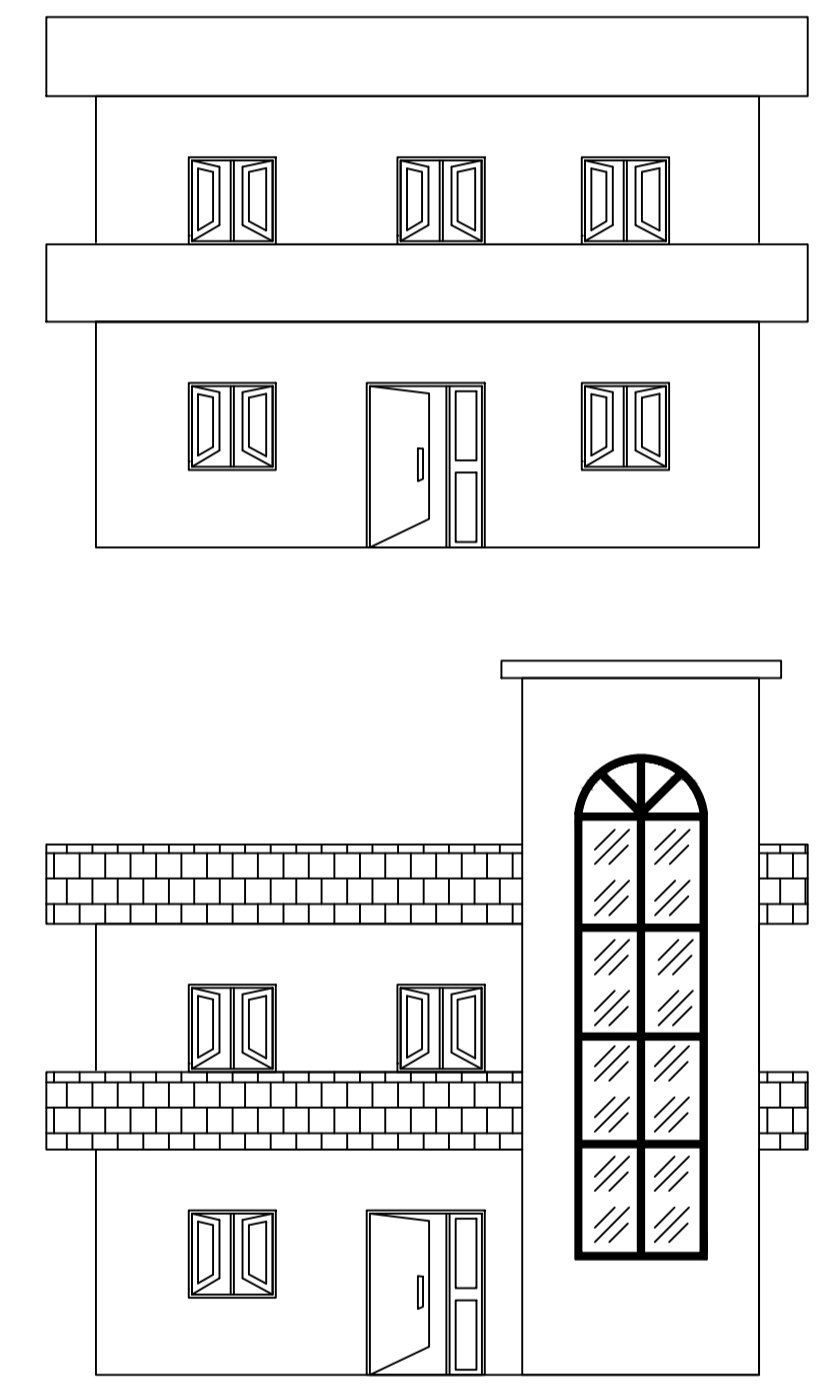
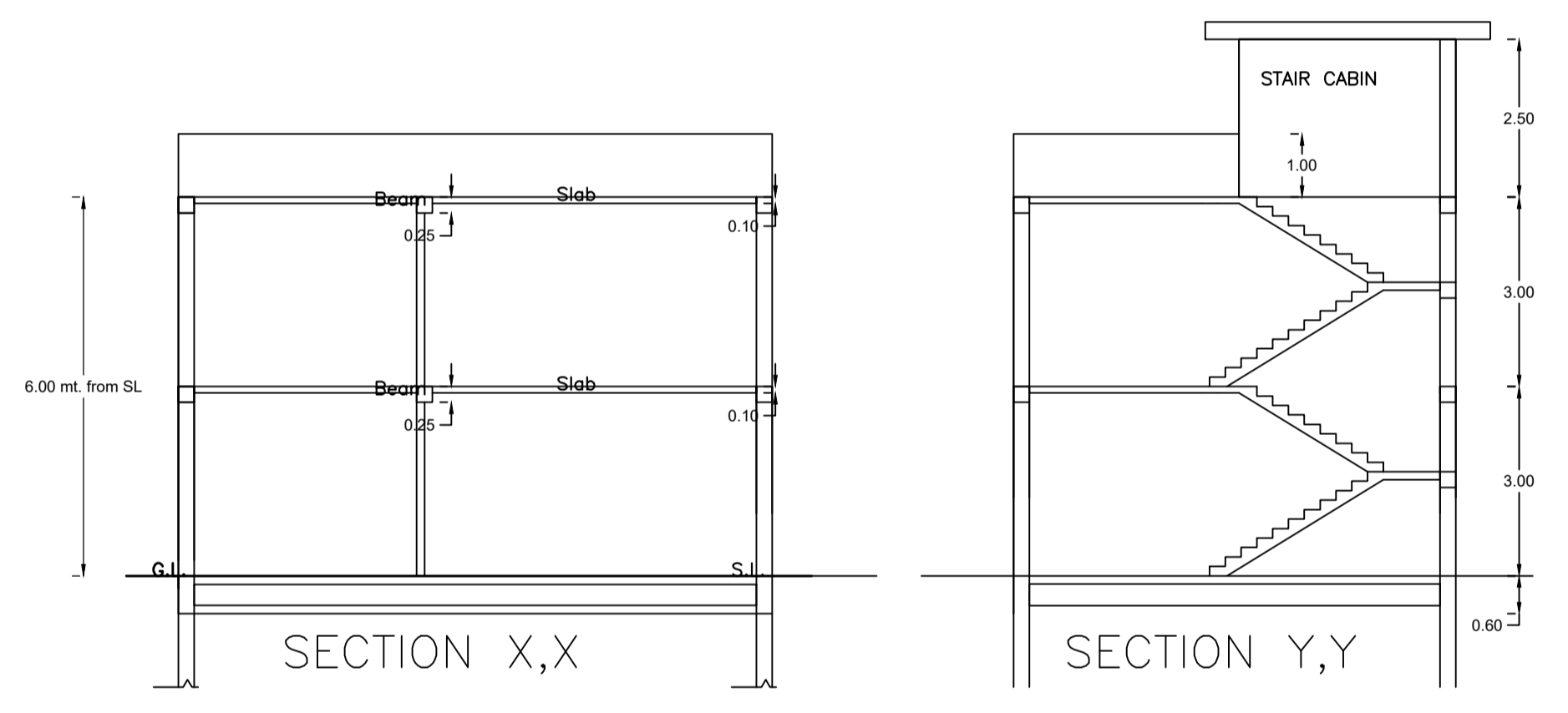
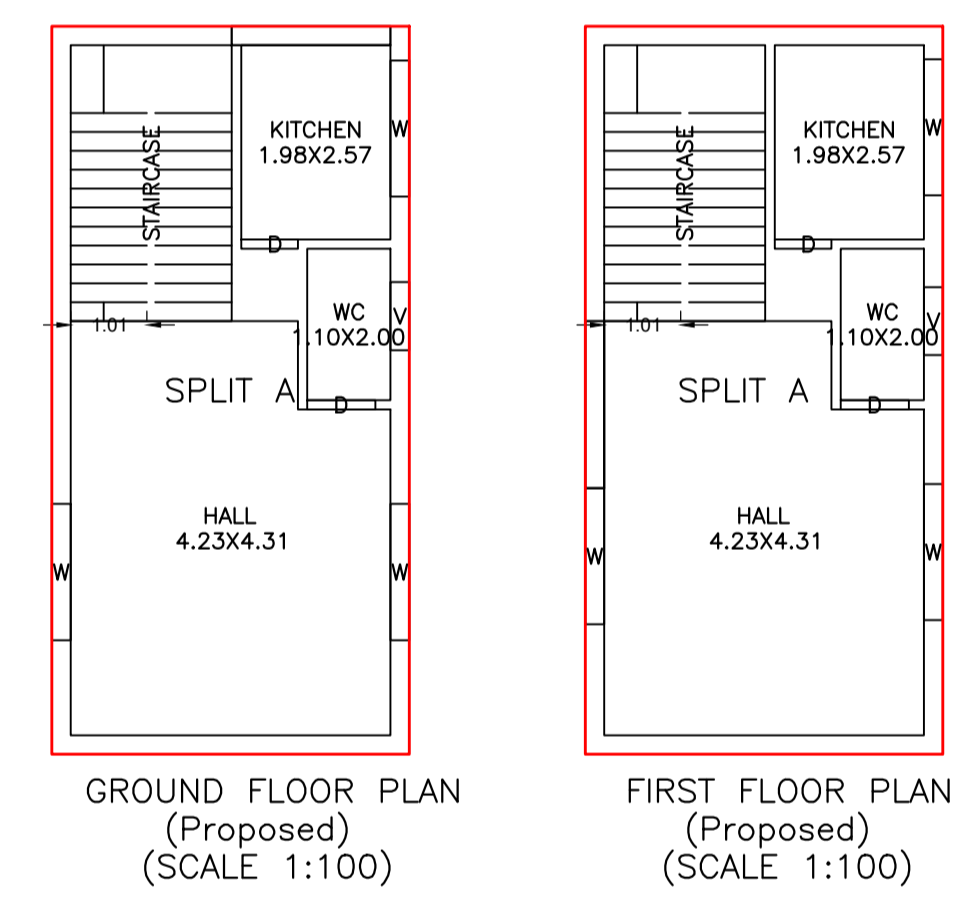

AREA STATEMENT  
MEDINAGAR MUNICIPAL CORPORATION  
VERSION NO.: 1.0.70  
VERSION DATE: 18/10/2020

PROJECT DETAIL:  
Region: JHARKHAND URBAN LOCAL BODIES  
District: PALAMU  
Authority: MEDINAGAR MUNICIPAL CORPORATION  
Inward No: MNNP/BP/0165/W06/2024  
Application Type: General Proposal  
Project Type: Building Permission  
Nature of Development: New  
Location of Development Area: Old Area

AREA DETAILS:	AREA OF PLOT (Minimum)	SQ.MT.
Area	(A)	82.37
Deduction for NetPlot Area		
Surrender Free of Cost		8.45
Total		8.45
NET AREA OF PLOT(Gross Plot Area - Deduction from Gross Plot area)	(A-Deductions)	73.92
Deduction for Balance Plot Area(from Gross Plot Area)		
Surrender Free of Cost		8.45
Common Plot		7.67
Total		16.11
BALANCE AREA OF PLOT(Net Plot Area - Recreational/Amenity space)	(A-Deductions)	66.26
PLOT AREA FOR COVERAGE(Net Plot Area)	(A-Deductions)	73.92
Plot Area for FAR (Net Plot Area + RoadWidening Area)	(A-Deductions)	82.37
COVERAGE CHECK		
Permissible Coverage area ( 70.00 % )		51.74
Proposed Coverage Area ( 61.62 % )		45.55
Total Prop. Coverage Area ( 61.62 % )		45.55
Balance coverage area ( 8.37 % )		6.19
FAR CHECK		
Perm. FAR Area ( 1.200 )		98.84
Total Perm. FAR area		98.84
Residential FAR		91.10
Proposed FAR Area		91.10
Total Proposed FAR Area		91.10
Consumed FAR (Factor)		1.11
Balance FAR Area		7.74
BUILT UP AREA CHECK		
Total Proposed BuiltUp Area		91.10
ARCHITECT (Regd)	Umesh Prasad	
ENGINEER (Regd)		
SUPERVISOR (Regd)		
OWNER (Regd)	Sanjay Kumar Singh	
DEVELOPMENT AUTHORITY	LOCAL BODY	

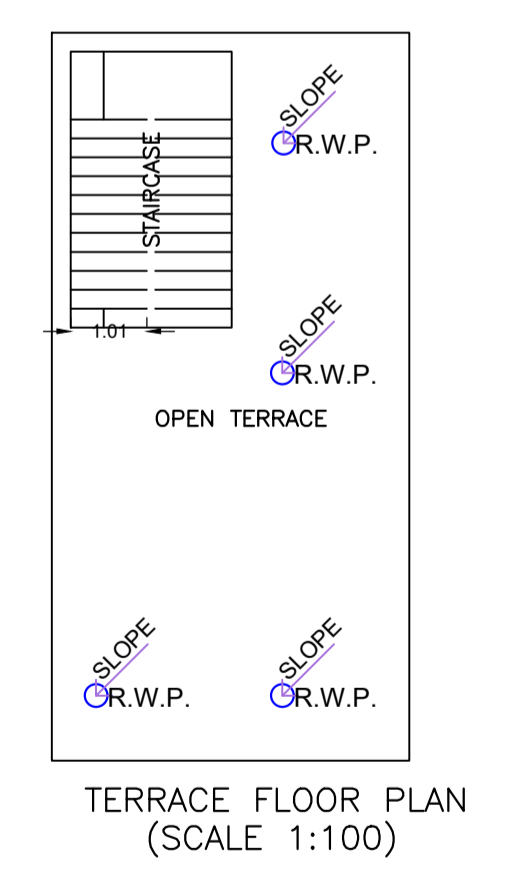

Building :A (BUILDING)

Floor Name	Total Built Up Area (Sq.mt.)	Proposed FAR Area (Sq.mt.) Resi.	Total FAR Area (Sq.mt.)	Total Consumed Additional FAR Area (Sq.mt.)	Tnmt (No.)
Ground Floor	45.55	45.55	45.55	45.55	01
First Floor	45.55	45.55	45.55	45.55	00
Terrace Floor	0.00	0.00	0.00	0.00	00
Total :	91.10	91.10	91.10	91.10	01
Total Number of Same Buildings :	1				
Total :	91.10	91.10	91.10	91.10	01

SCHEDULE OF DOOR:

BUILDING NAME	NAME	LENGTH	HEIGHT	NOS
A (BUILDING)	D	0.75	2.10	02
A (BUILDING)	D	0.90	2.10	02

SCHEDULE OF WINDOW/VENTILATION:

BUILDING NAME	NAME	LENGTH	HEIGHT	NOS
A (BUILDING)	V	0.90	0.60	02
A (BUILDING)	W	1.80	1.20	06

UnitBUA Table for Building :A (BUILDING)

FLOOR	Name	UnitBUA Type	UnitBUA Area	Carpet Area	No. of Rooms	No. of Tenement
GROUND FLOOR PLAN	SPLIT A	FLAT	72.54	71.46	3	1
FIRST FLOOR PLAN	SPLIT A	FLAT	0.00	0.00	3	0
Total:	-	-	72.54	71.46	6	1

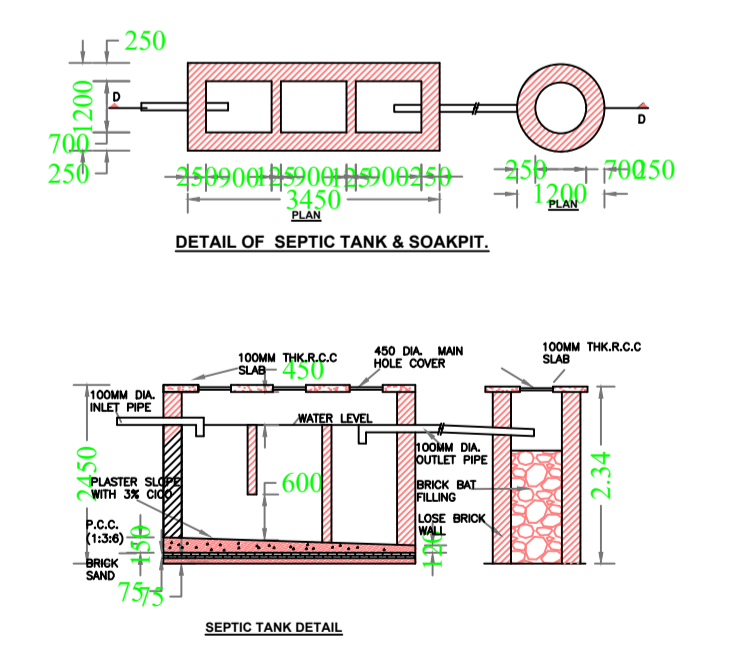

Buildingwise Floor FAR Details

Floor Name	Building Name A (BUILDING)		Total	
	Proposed Built Up Area (Sq.mt.)	Proposed FAR Area (Sq.mt.)	Total Proposed Built Up Area (Sq.mt.)	Total FAR Area (Sq.mt.)
Ground Floor	45.55	45.55	45.55	45.55
First Floor	45.55	45.55	45.55	45.55
Terrace Floor	0.00	0.00	0.00	0.00
Total :	91.10	91.10	91.10	91.10

Building USE/SUBUSE Details

Building Name	Building Use	Building SubUse	Building Structure
A (BUILDING)	Residential	Bungalow Dwelling / Non Apartment	Non-Highrise

LTP NAME AND SIGNATURE	STRUCTURAL ENG'S NAME AND SIGNATURE	BUILDER NAME AND SIGNATURE	DIGITAL SIGNATURE
Umesh Prasad MNNP/ENG/002/2024			