

Proposal Basic Information	
Proposal File No.	MNNP/BP/0166/W03/2024
Owner Name	Wajanti Devi
Khata No	8
Plot No	250
Village Name	Sudma Bariya
Use	Residential
SubUse	Bungalow/ Dwelling / Non Apartment

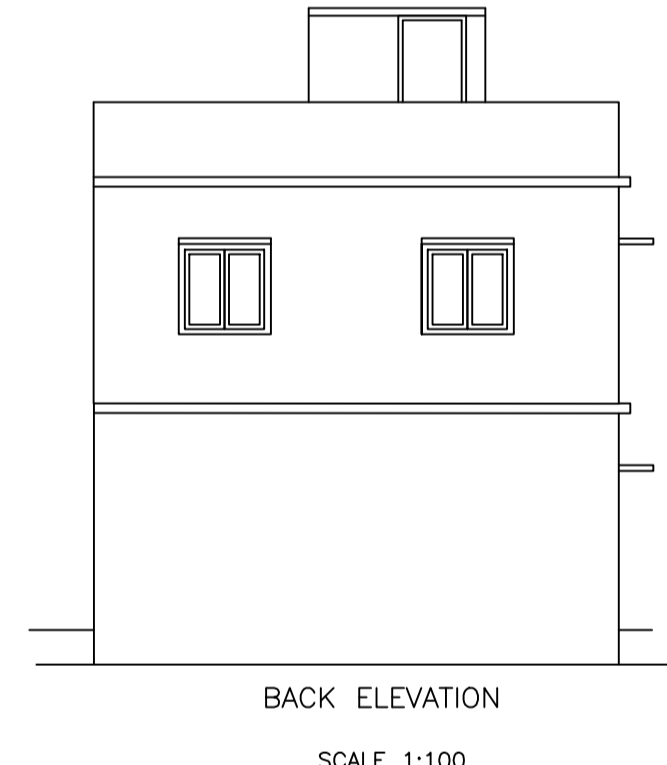
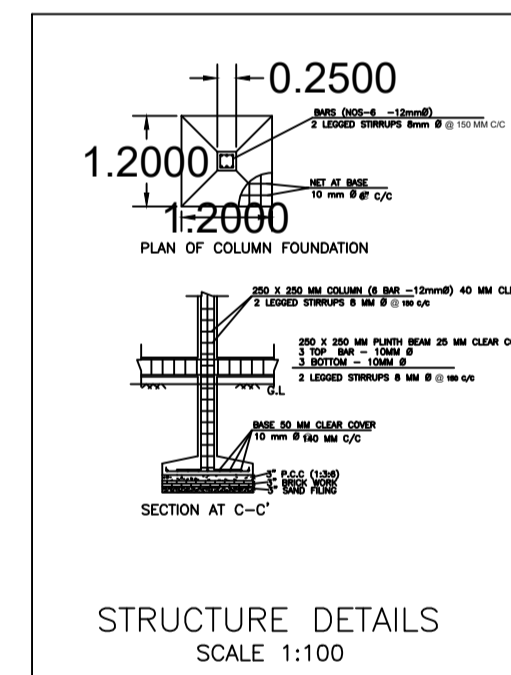
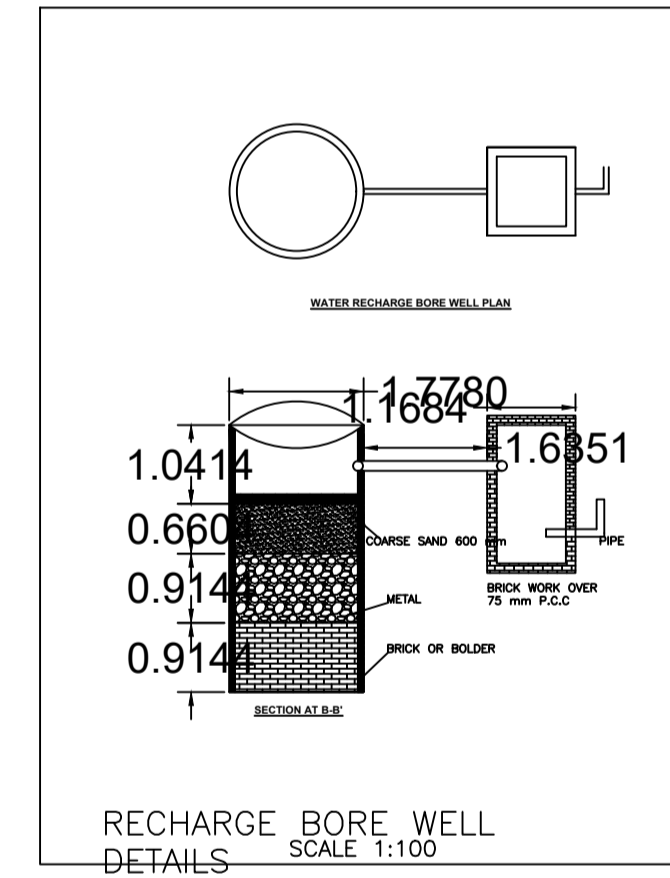
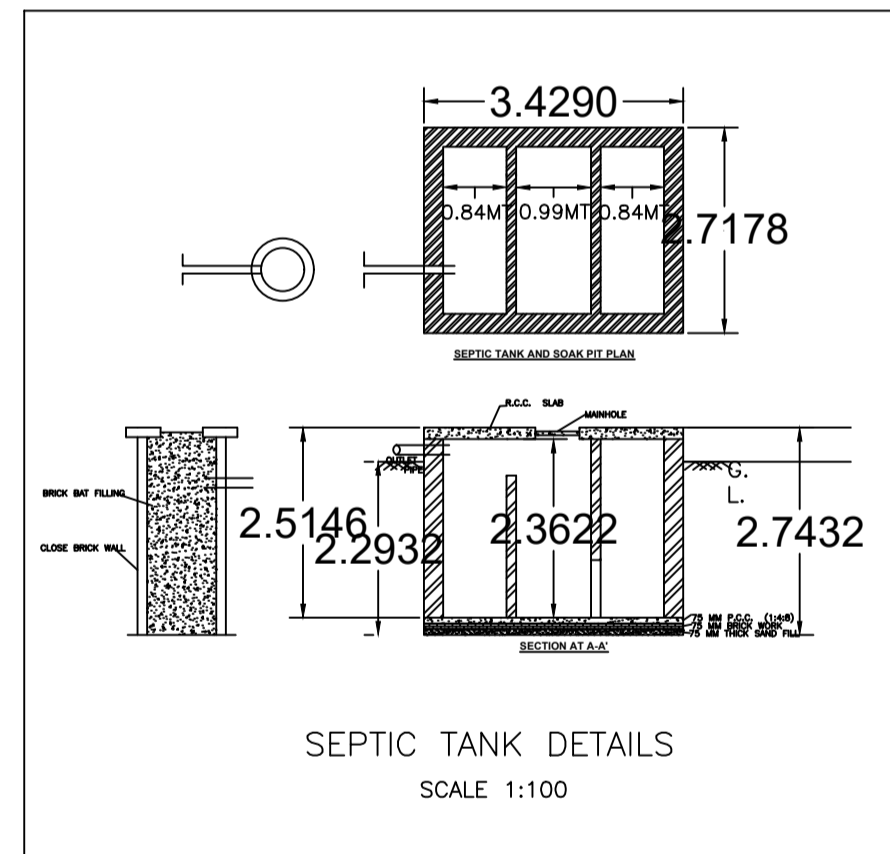
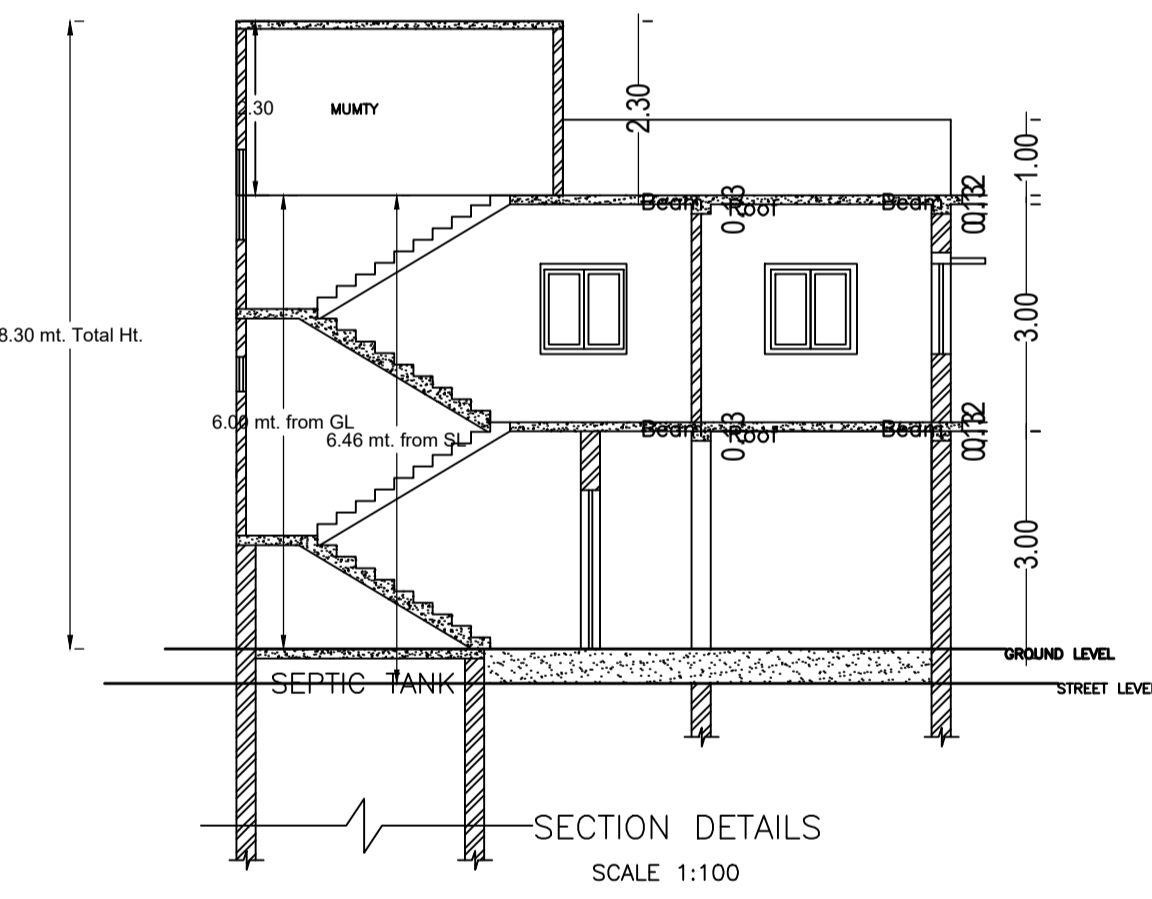
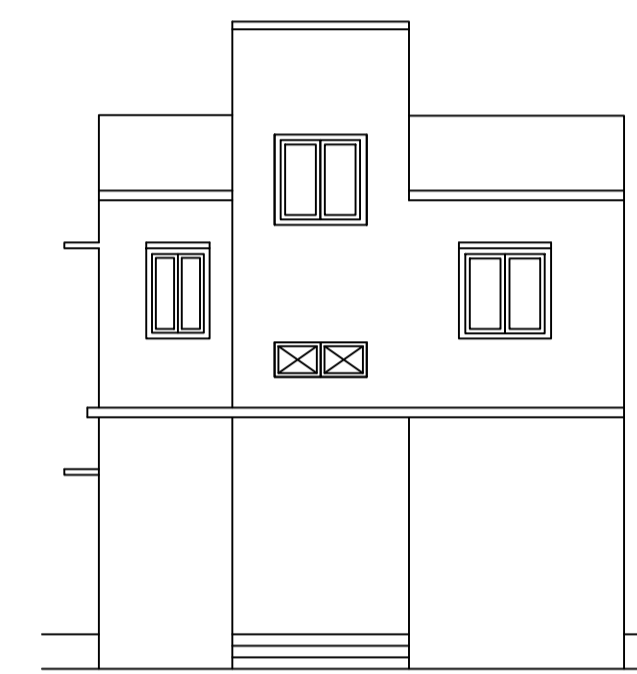
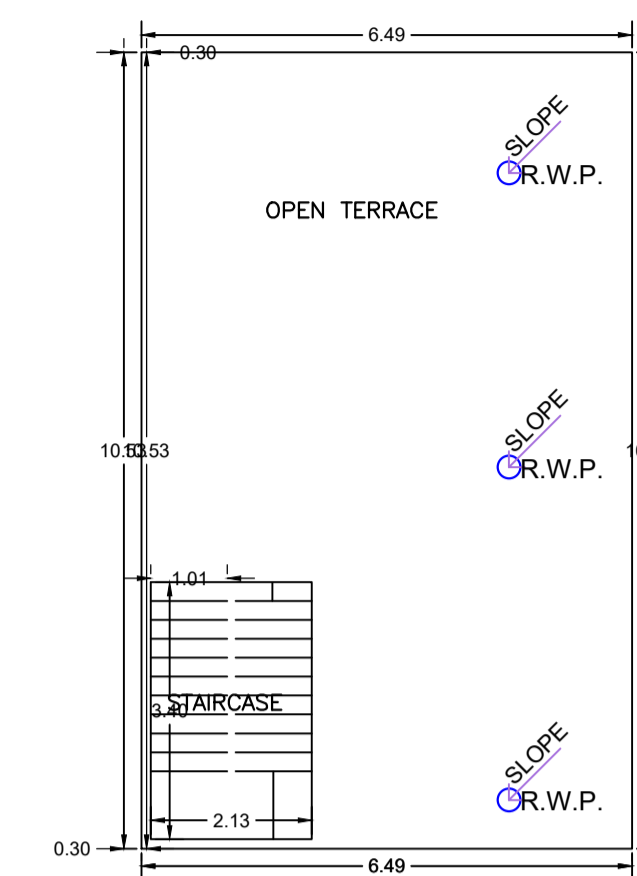
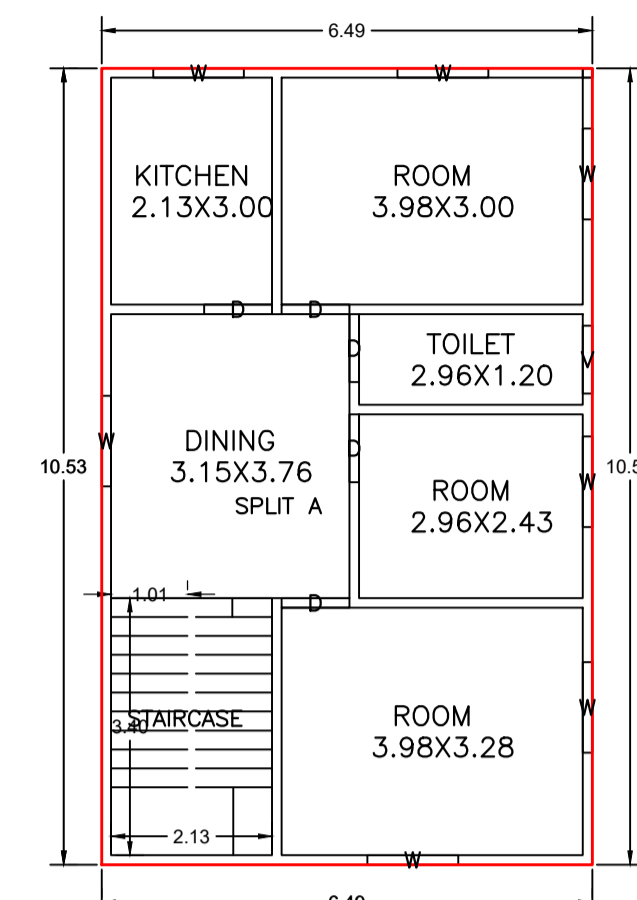
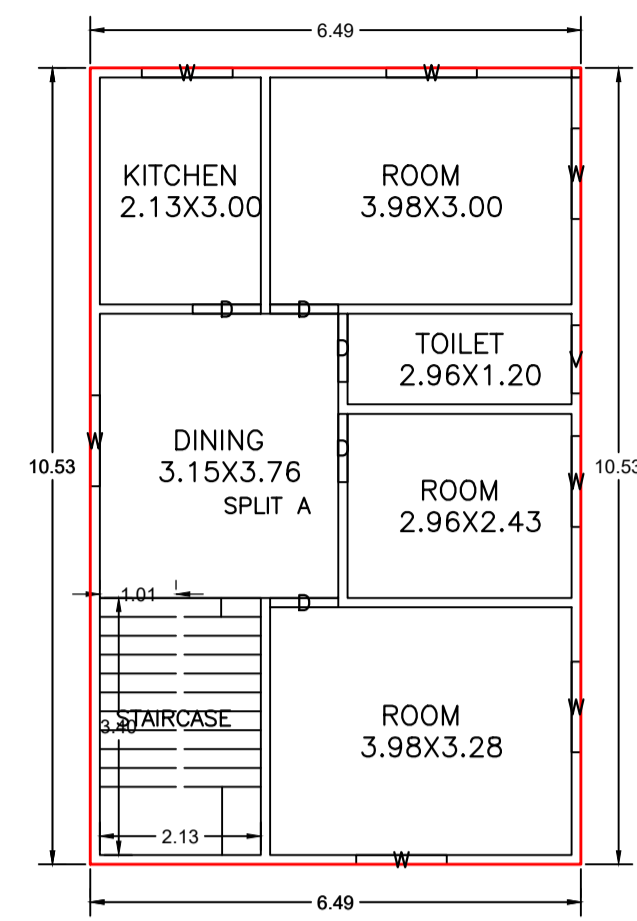
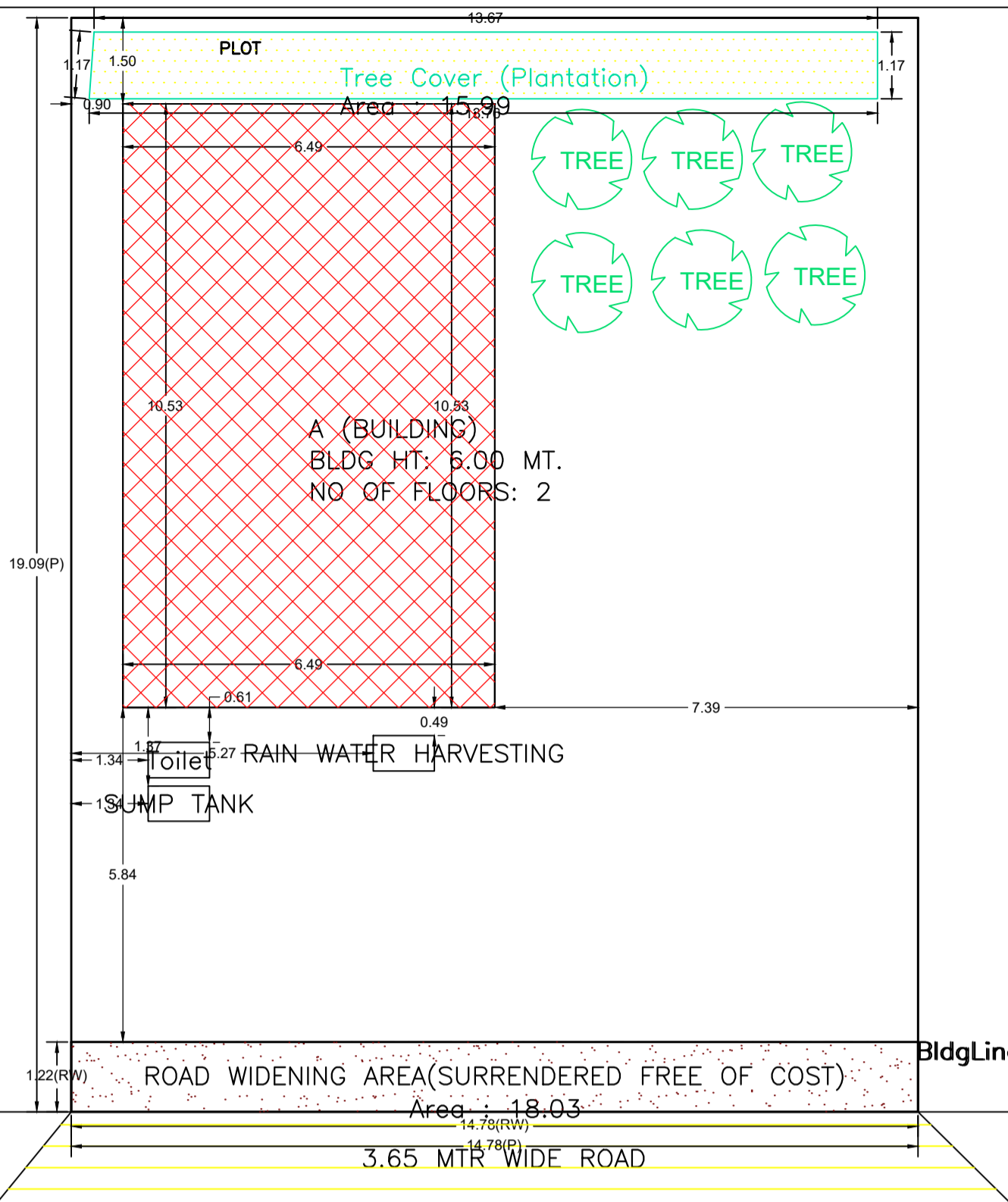

AREA STATEMENT		VERSION NO.: 1.0.70
MEDINAGAR MUNICIPAL CORPORATION		VERSION DATE: 16/10/2020
PROJECT DETAIL:		
Region: JHARKHAND URBAN LOCAL BODIES	Plot Use: Residential	
District: PALAMU	Plot SubUse: Bungalow/ Dwelling / Non Apartment	
Authority: MEDINAGAR MUNICIPAL CORPORATION	PlotNearbyReligiousStructure: NA	
Inward_No: MNNP/BP/0166/W03/2024	Plot/SubPlot No: 250	
Application Type: General Proposal	North: -	
Project Type: Building Permission	South: -	
Nature of Development: New	East: -	
Location of Development Area: New Area	West: -	
AREA DETAILS:		
AREA OF PLOT (Minimum)	(A)	SQ.MT. 282.19
Deduction for NetPlot Area		
Surrender Free of Cost		18.03
Total		18.03
NET AREA OF PLOT(Gross Plot Area - Deduction from Gross Plot area)	(A-Deductions)	264.16
Deduction for Balance Plot Area(from Gross Plot Area)		
Surrender Free of Cost		18.03
Common Plot		15.99
Total		34.02
BALANCE AREA OF PLOT(Net Plot Area - Recreational/Amenity space)	(A-Deductions)	248.17
PLOT AREA FOR COVERAGE(Net Plot Area)	(A-Deductions)	264.16
Plot Area for FAR (Net Plot Area + RoadWidening Area)	(A-Deductions)	282.19
COVERAGE CHECK		
Permissible Coverage area (60.00 %)		158.50
Proposed Coverage Area (25.88 %)		68.36
Total Prop. Coverage Area (25.88 %)		68.36
Balance coverage area (34.12 %)		90.14
FAR CHECK		
Perm. FAR Area (1.500)		423.29
Total Perm. FAR area		423.29
Residential FAR		136.71
Proposed FAR Area		136.71
Total Proposed FAR Area		136.71
Consumed FAR (Factor)		0.48
Balance FAR Area		286.58
BUILT UP AREA CHECK		
Total Proposed BuiltUp Area		136.72
ARCHITECT (Regd)	PANKAJ KUMAR SINGH	
ENGINEER (Regd)		
SUPERVISOR (Regd)		
OWNER (Regd)	Wajanti Devi	
DEVELOPMENT AUTHORITY		LOCAL BODY

Building USE/SUBUSE Details			
Building Name	Building Use	Building SubUse	Building Structure
A (BUILDING)	Residential	Bungalow/ Dwelling / Non Apartment	Non-Highrise

Buildingwise Floor FAR Details				
Floor Name	Building Name		Total	
	Proposed Built Up Area (Sq.mt.)	Proposed FAR Area (Sq.mt.)	Total Proposed Built Up Area (Sq.mt.)	Total FAR Area (Sq.mt.)
Ground Floor	68.36	68.36	68.36	68.36
First Floor	68.36	68.36	68.36	68.36
Terrace Floor	0.00	0.00	0.00	0.00
Total :	136.72	136.72	136.72	136.72

COLOR INDEX	
PLOT BOUNDARY	Black
ABUTTING ROAD	Green
PROPOSED CONSTRUCTION	Red
COMMON PLOT	Yellow
ROAD WIDENING AREA	Blue
EXISTING (To be retained)	Orange
EXISTING (To be demolished)	Light Blue

SCHEDULE OF DOOR:

BUILDING NAME	NAME	LENGTH	HEIGHT	NOS
A (BUILDING)	D	0.90	2.10	10

SCHEDULE OF WINDOW/VENTILATION:

BUILDING NAME	NAME	LENGTH	HEIGHT	NOS
A (BUILDING)	V	0.90	0.60	02
A (BUILDING)	W	1.20	1.20	14

Building :A (BUILDING)

Floor Name	Total Built Up Area (Sq.mt.)	Proposed FAR Area (Sq.mt.)	Total FAR Area (Sq.mt.)	Total Consumed Additional FAR Area (Sq.mt.)	Tnmt (No.)
Ground Floor	68.36	68.36	68.36	68.36	01
First Floor	68.36	68.36	68.36	68.36	00
Terrace Floor	0.00	0.00	0.00	0.00	00
Total	136.72	136.72	136.72	136.72	01
Total Number of Same Buildings	1				
Total :	136.72	136.72	136.72	136.72	01

UnitBUA Table for Building :A (BUILDING)

FLOOR	Name	UnitBUA Type	UnitBUA Area	Carpet Area	No. of Rooms	No. of Tenement
GROUND FLOOR PLAN	SPLIT A	FLAT	120.81	120.78	6	1
FIRST FLOOR PLAN	SPLIT A	FLAT	0.00	0.00	6	0
Total:	-	-	120.81	120.78	12	1

FAR & Tenement Details (Table 4c-1)

Building	No. of Same Bldg	Total Built Up Area (Sq.mt.)	Proposed FAR Area (Sq.mt.)	Total FAR Area (Sq.mt.)	Total Consumed Additional FAR Area (Sq.mt.)	Tnmt (No.)
A (BUILDING)	1	136.72	136.72	136.72	136.72	01
Grand Total :	1	136.72	136.72	136.72	136.72	01

LTP NAME AND SIGNATURE	STRUCTURAL ENG'S NAME AND SIGNATURE	BUILDER NAME AND SIGNATURE	DIGITAL SIGNATURE
PANKAJ KUMAR SINGH MNNP/ENG/006/2019			