

FAR & Tenement Details (Table 4c-1)

Building	No. of Same Bldg	Total Built Up Area (Sq.mt.)	Proposed FAR Area (Sq.mt.) Resi.	Total FAR Area (Sq.mt.)	Total Consumed Additional FAR Area (Sq.mt.)	Tnmt (No.)
A (RESIDENTIAL)	1	261.04	261.04	261.04	261.04	01
<b>Grand Total :</b>	<b>1</b>	<b>261.04</b>	<b>261.04</b>	<b>261.04</b>	<b>261.04</b>	<b>01</b>

Proposal Basic Information

Proposal File No.	MNNP/BP/0167/W08/2024
Owner Name	DHRUV NARAYAN PANDEY
Khata No	102
Plot No	147
Village Name	Baralota
Use	Residential
SubUse	Bungalow/ Dwelling / Non Apartment

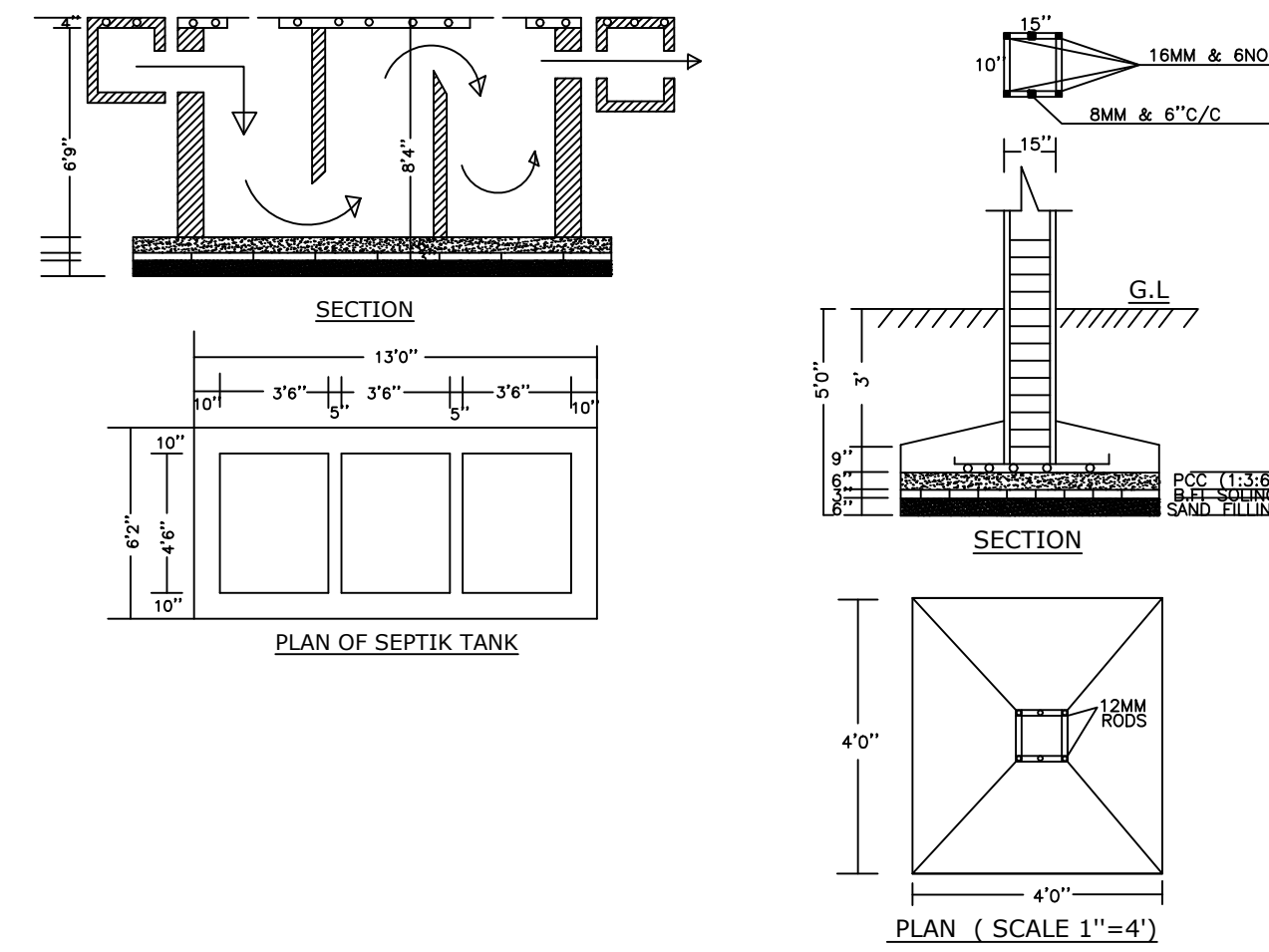

AREA STATEMENT		VERSION NO. : 1.070
MEDINAGAR MUNICIPAL CORPORATION		VERSION DATE: 18/10/2020
<b>PROJECT DETAIL:</b>		
Region : JHARKHAND URBAN LOCAL BODIES	Plot Use: Residential	
District: PALAMU	Plot SubUse: Bungalow/ Dwelling / Non Apartment	
Authority: MEDINAGAR MUNICIPAL CORPORATION	Plot/Nearby/Religious/Structure: NA	
Inward No: MNNP/BP/0167/W08/2024	Plot/SubPlot No: 147	
Application Type: General Proposal	North: -	
Project Type: Building Permission	South: -	
Nature of Development: New	East: -	
Location of Development Area: New	West: -	
<b>AREA DETAILS:</b>		
AREA OF PLOT (Minimum)	(A)	SQ.MT.
NET AREA OF PLOT(Gross Plot Area - Deduction from Gross Plot area)	(A-Deductions)	303.62
Deduction for Balance Plot Area(from Gross Plot Area)		
Common Plot		68.55
Total		68.55
BALANCE AREA OF PLOT(Net Plot Area - Recreational/Amenity space)	(A-Deductions)	235.07
PLOT AREA FOR COVERAGE(Net Plot Area)	(A-Deductions)	303.62
Plot Area for FAR (Net Plot Area + Road Widening Area)	(A-Deductions)	303.62
<b>COVERAGE CHECK</b>		
Permissible Coverage area ( 60.00 % )		182.17
Proposed Coverage Area ( 42.99 % )		130.52
Total Prop. Coverage Area ( 42.99 % )		130.52
Balance coverage area ( 17.01 % )		51.65
<b>FAR CHECK</b>		
Perm. FAR Area ( 2.000 )		607.24
Total Perm. FAR area		607.24
Residential FAR		261.04
Proposed FAR Area		261.04
Total Proposed FAR Area		261.04
Consumed FAR (Factor)		0.86
Balance FAR Area		346.20
<b>BUILT UP AREA CHECK</b>		
Total Proposed BuiltUp Area		261.04
ARCHITECT (Regd)	Umesh Prasad	
ENGINEER (Regd)		
SUPERVISOR (Regd)		
OWNER (Regd)	DHRUV NARAYAN PANDEY	
DEVELOPMENT AUTHORITY		LOCAL BODY

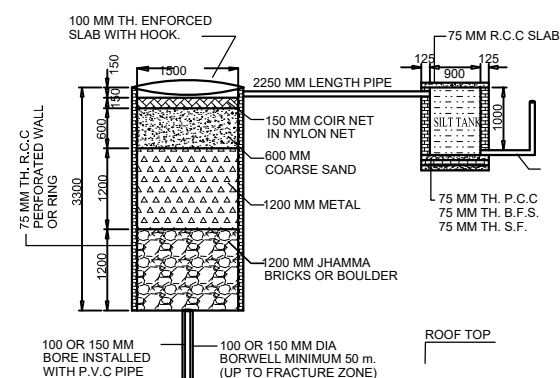
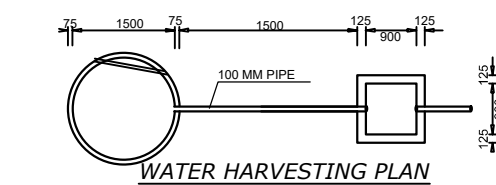
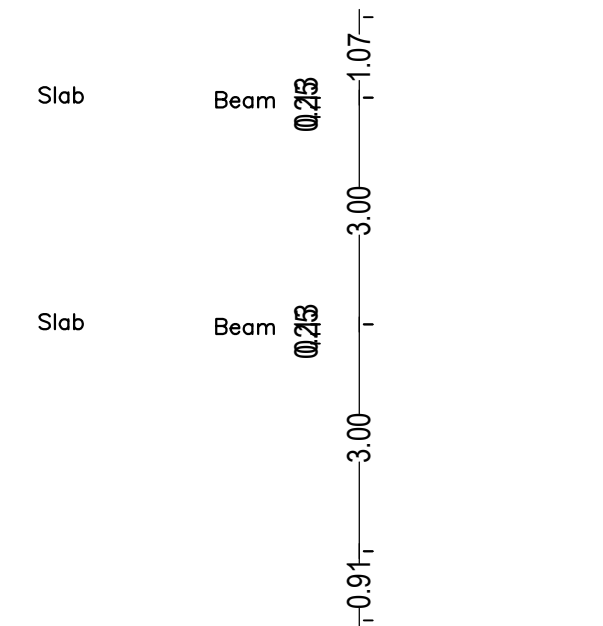
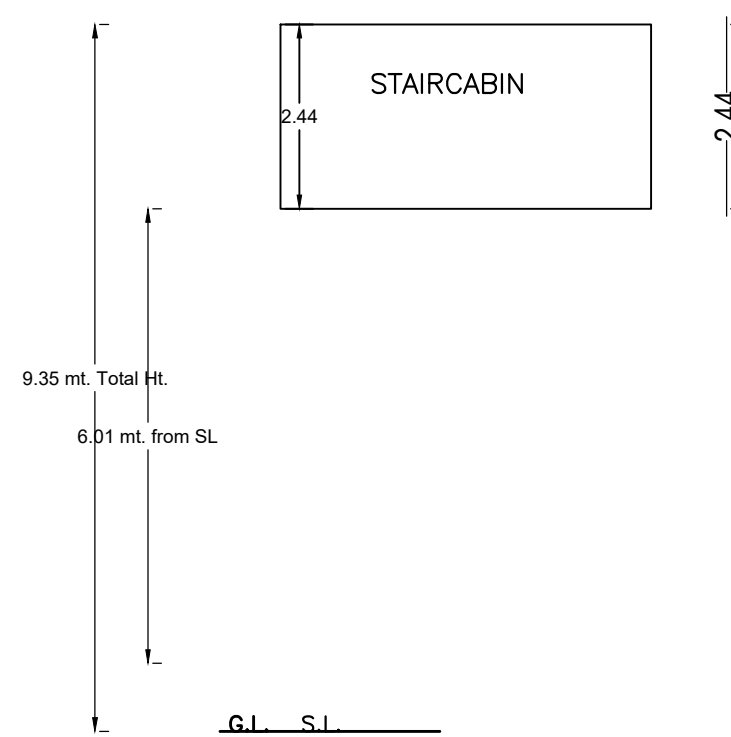
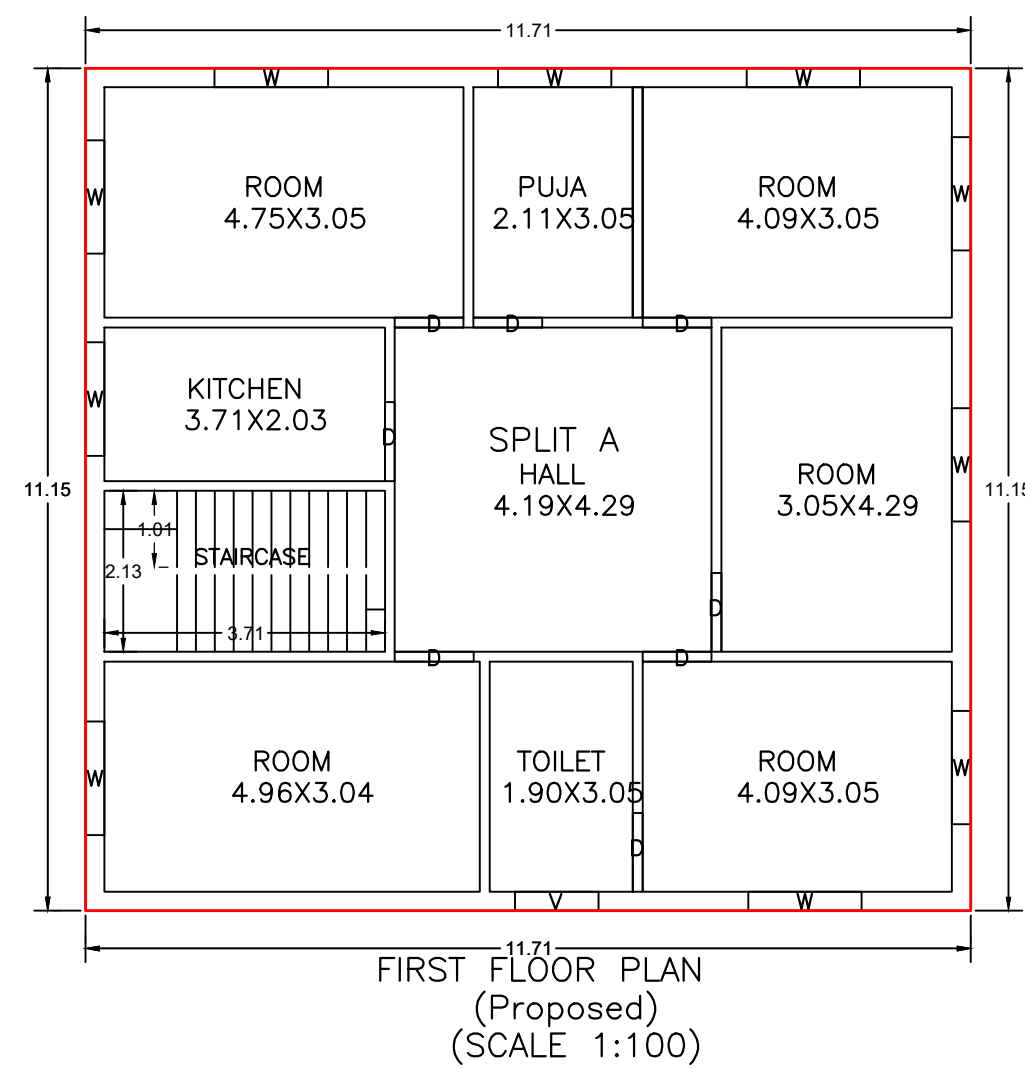
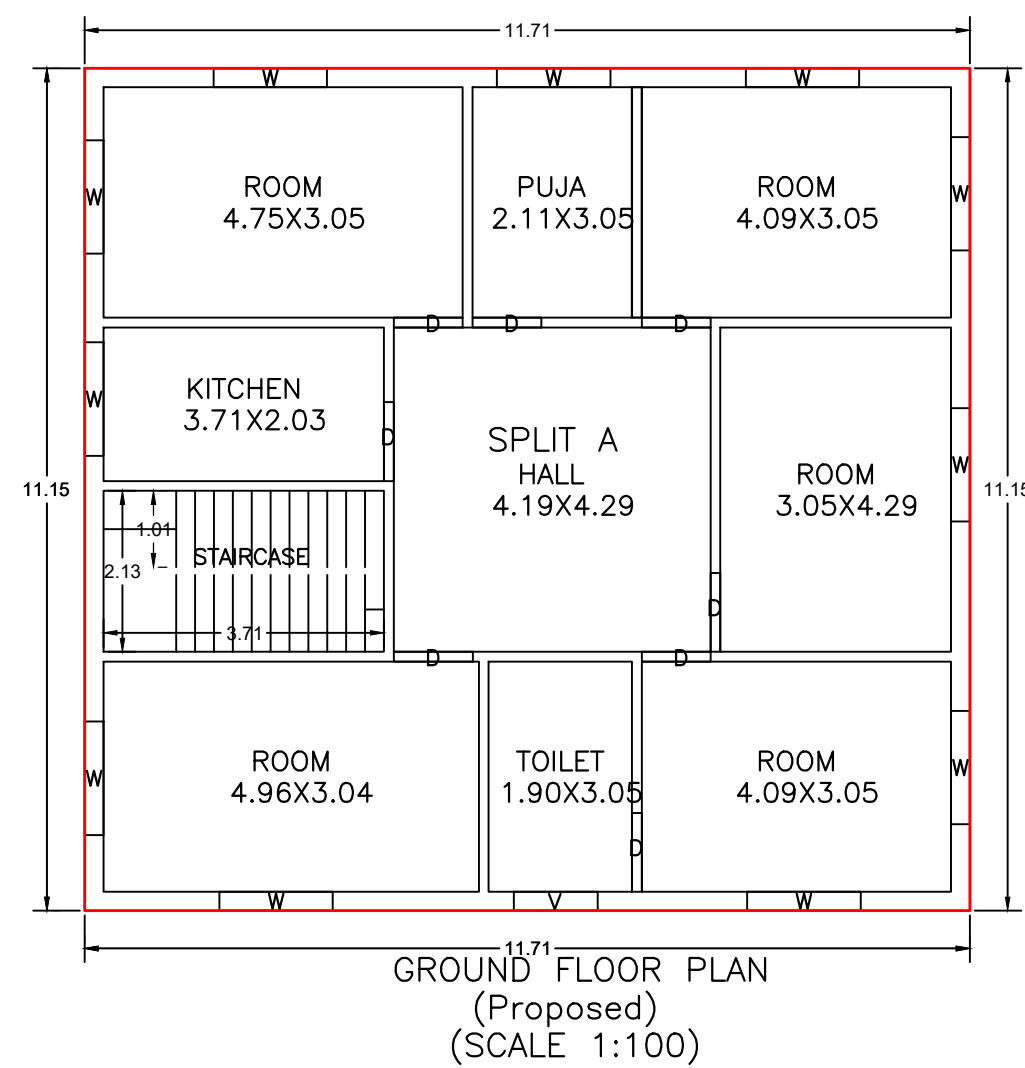

COLOR INDEX	
PLOT BOUNDARY	Black
ABUTTING ROAD	Red
PROPOSED CONSTRUCTION	Green
COMMON PLOT	Yellow
ROAD WIDENING AREA	Blue
EXISTING (To be retained)	White
EXISTING (To be demolished)	Grey

Buildingwise Floor FAR Details

Floor Name	Building Name A (RESIDENTIAL)		Total	
	Proposed Built Up Area (Sq.mt.)	Proposed FAR Area (Sq.mt.)	Total Proposed Built Up Area (Sq.mt.)	Total FAR Area (Sq.mt.)
Ground Floor	130.52	130.52	130.52	130.52
First Floor	130.52	130.52	130.52	130.52
Terrace Floor	0.00	0.00	0.00	0.00
<b>Total :</b>	<b>261.04</b>	<b>261.04</b>	<b>261.04</b>	<b>261.04</b>

Building USE/SUBUSE Details

Building Name	Building Use	Building SubUse	Building Structure
A (RESIDENTIAL)	Residential	Bungalow/ Dwelling / Non Apartment	Non-Highrise

Building : A (RESIDENTIAL)

Floor Name	Total Built Up Area (Sq.mt.)	Proposed FAR Area (Sq.mt.) Resi.	Total FAR Area (Sq.mt.)	Total Consumed Additional FAR Area (Sq.mt.)	Tnmt (No.)
Ground Floor	130.52	130.52	130.52	130.52	01
First Floor	130.52	130.52	130.52	130.52	00
Terrace Floor	0.00	0.00	0.00	0.00	00
<b>Total :</b>	<b>261.04</b>	<b>261.04</b>	<b>261.04</b>	<b>261.04</b>	<b>01</b>
Total Number of Same Buildings	1				
<b>Total :</b>	<b>261.04</b>	<b>261.04</b>	<b>261.04</b>	<b>261.04</b>	<b>01</b>

SCHEDULE OF DOOR:

BUILDING NAME	NAME	LENGTH	HEIGHT	NOS
A (RESIDENTIAL)	D	0.91	2.10	08
A (RESIDENTIAL)	D	1.04	2.10	08

SCHEDULE OF WINDOW/VENTILATION:

BUILDING NAME	NAME	LENGTH	HEIGHT	NOS
A (RESIDENTIAL)	V	1.11	1.20	02
A (RESIDENTIAL)	W	1.50	1.20	21

UnitBUA Table for Building : A (RESIDENTIAL)

FLOOR	Name	UnitBUA Type	UnitBUA Area	Carpel Area	No. of Rooms	No. of Tenement
GROUND FLOOR PLAN	SPLIT A	FLAT	244.17	243.38	9	1
FIRST FLOOR PLAN	SPLIT A	FLAT	0.00	0.00	9	0
<b>Total:</b>	-	-	<b>244.17</b>	<b>243.38</b>	<b>18</b>	<b>1</b>

LTP NAME AND SIGNATURE	STRUCTURAL ENG'S NAME AND SIGNATURE	BUILDER NAME AND SIGNATURE	DIGITAL SIGNATURE
Umesh Prasad MNNP/ENG/0002/2024			