

Proposal Basic Information

Proposal File No.	MNNP/BP/0065/W09/2024
Owner Name	GITA DEVI
Khata No	41
Plot No	833
Village Name	Sudna
Use	Residential
SubUse	Bungalow/ Dwelling / Non Apartment

FAR & Tenement Details (Table 4c-1)

Building	No. of Same Bldg	Total Built Up Area (Sq.mt.)	Proposed FAR Area (Sq.mt.) Resi.	Total FAR Area (Sq.mt.)	Total Consumed Additional FAR Area (Sq.mt.)	Tnmt (No.)
A (RESIDENTIAL)	1	30.13	30.13	30.13	30.13	01
Grand Total :	1	30.13	30.13	30.13	30.13	01

AREA STATEMENT	VERSION NO. : 1.0.69
MEDININAGAR MUNICIPAL CORPORATION	VERSION DATE: 16/10/2020
PROJECT DETAIL:	
Region: JHARKHAND URBAN LOCAL BODIES	Plot Use: Residential
District: PALAMU	Plot SubUse: Bungalow/ Dwelling / Non Apartment
Authority: MEDININAGAR MUNICIPAL CORPORATION	PlotNearbyReligiousStructure: NA
Inward No: MNNP/BP/0065/W09/2024	Plot/SubPlot No: 833
Application Type: General Proposal	North: -
Project Type: Building Permission	South: -
Nature of Development: New	East: -
Location of Development Area: New Area	West: -
AREA DETAILS:	
AREA OF PLOT (Minimum)	(A) 60.72
Deduction for NetPlot Area	
Surrender Free of Cost	5.95
Total	5.95
NET AREA OF PLOT(Gross Plot Area - Deduction from Gross Plot area)	(A-Deductions) 54.77
Deduction for Balance Plot Area(from Gross Plot Area)	
Surrender Free of Cost	5.95
Common Plot	5.85
Total	11.80
BALANCE AREA OF PLOT(Net Plot Area - Recreational/Amenity space)	(A-Deductions) 48.92
PLOT AREA FOR COVERAGE(Net Plot Area)	(A-Deductions) 54.77
Plot Area for FAR (Net Plot Area + Road/Widening Area)	(A-Deductions) 60.72
COVERAGE CHECK	
Permissible Coverage area (70.00 %)	38.34
Proposed Coverage Area (55.01 %)	30.13
Total Prop. Coverage Area (55.01 %)	30.13
Balance coverage area (14.99 %)	8.21
FAR CHECK	
Perm. FAR Area (1.200)	72.86
Total Perm. FAR area	72.86
Residential FAR	30.13
Proposed FAR Area	30.13
Total Proposed FAR Area	30.13
Consumed FAR (Factor)	0.50
Balance FAR Area	42.73
BUILT UP AREA CHECK	
Total Proposed BuiltUp Area	30.13
ARCHITECT (Regd)	RANJIT KUMAR
ENGINEER (Regd)	
SUPERVISOR (Regd)	
OWNER (Regd)	GITA DEVI
DEVELOPMENT AUTHORITY LOCAL BODY	

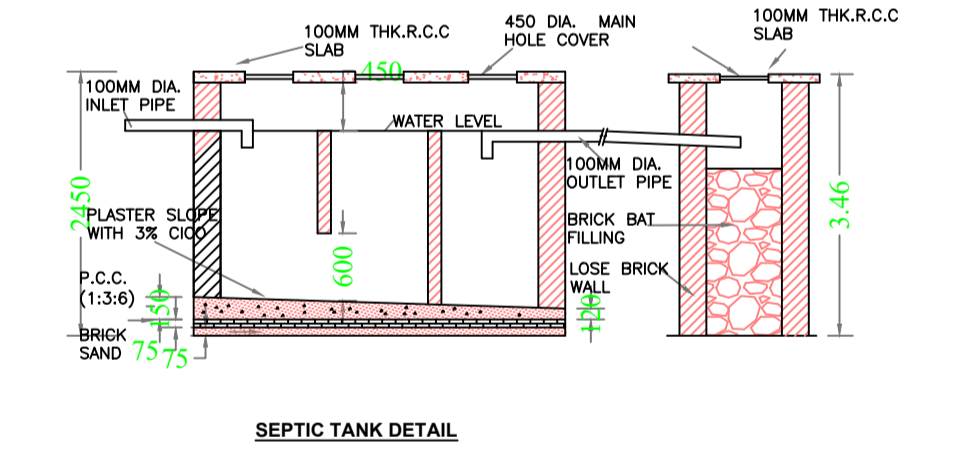
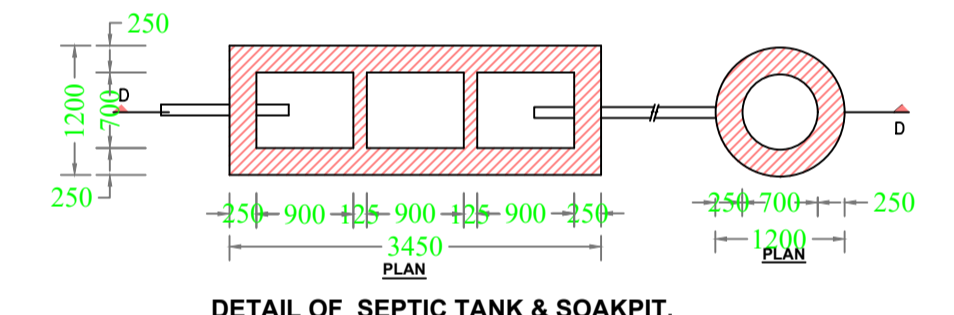
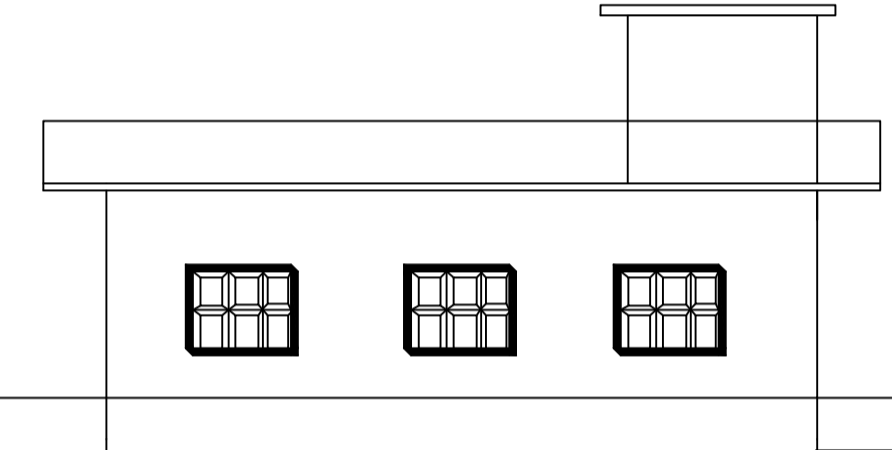
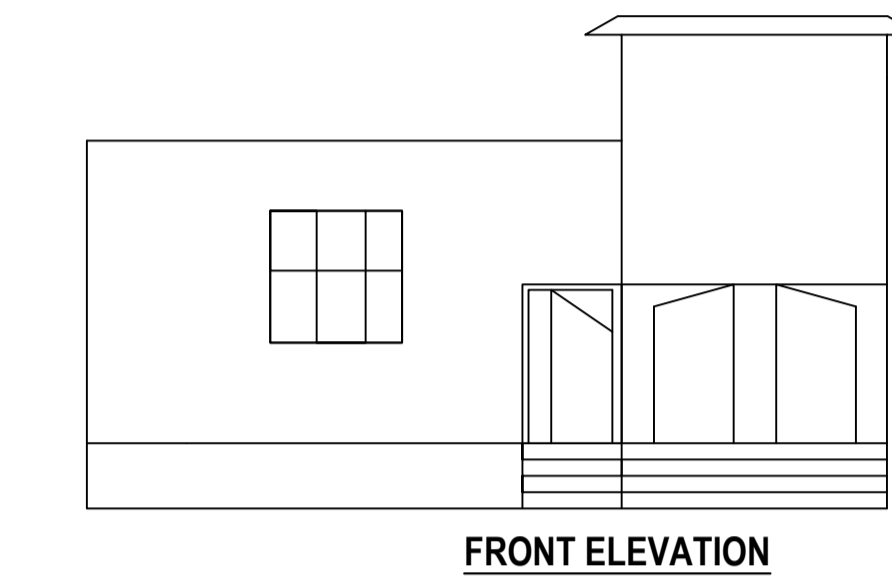

COLOR INDEX	
PLOT BOUNDARY	[Red Line]
ABUTTING ROAD	[Green Line]
PROPOSED CONSTRUCTION	[Yellow Line]
COMMON PLOT	[Blue Line]
ROAD WIDENING AREA	[Orange Line]
EXISTING (To be retained)	[Grey Line]
EXISTING (To be demolished)	[Black Line]

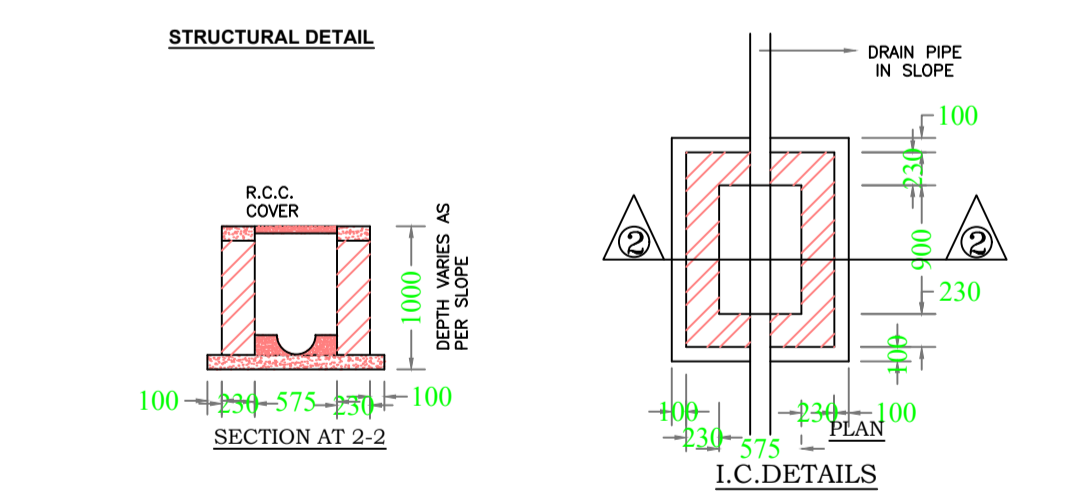
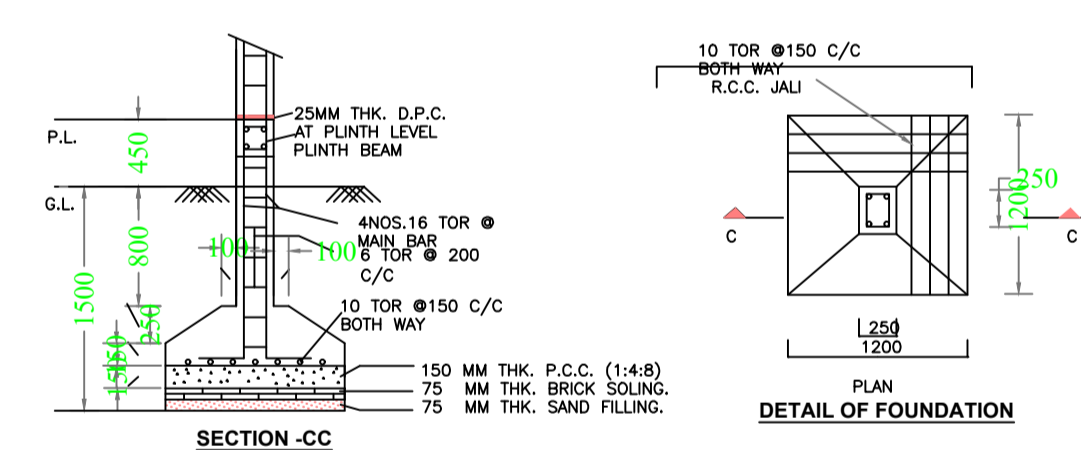
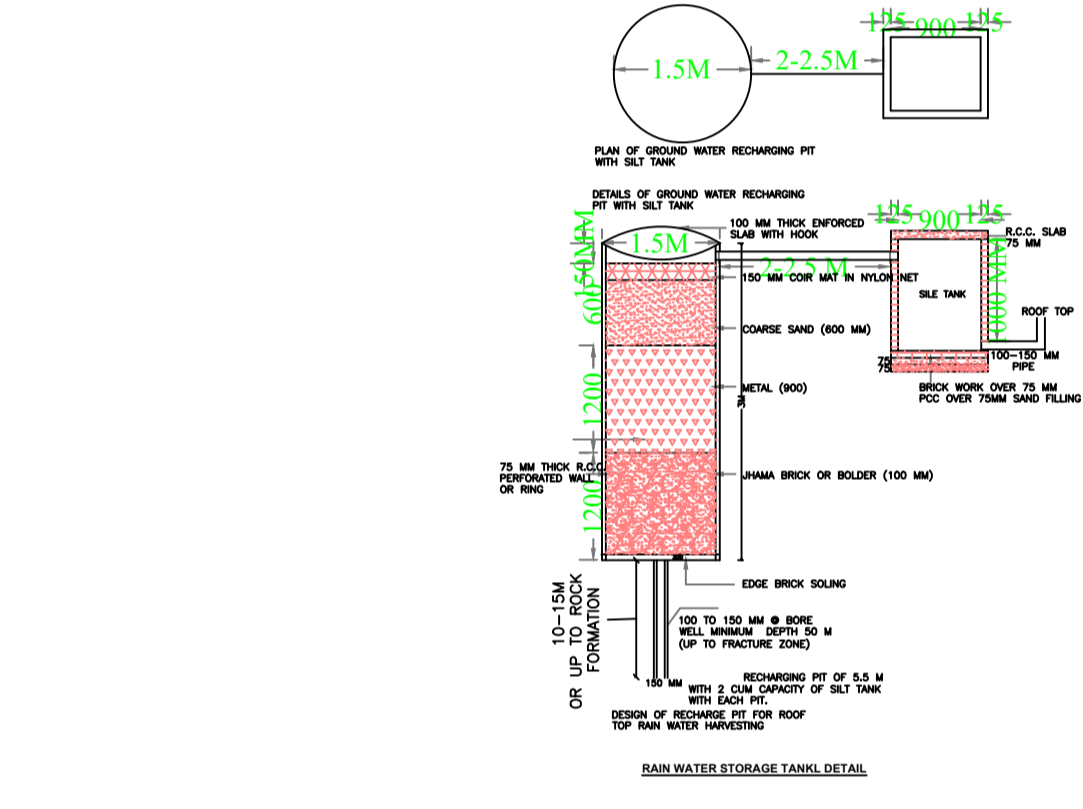
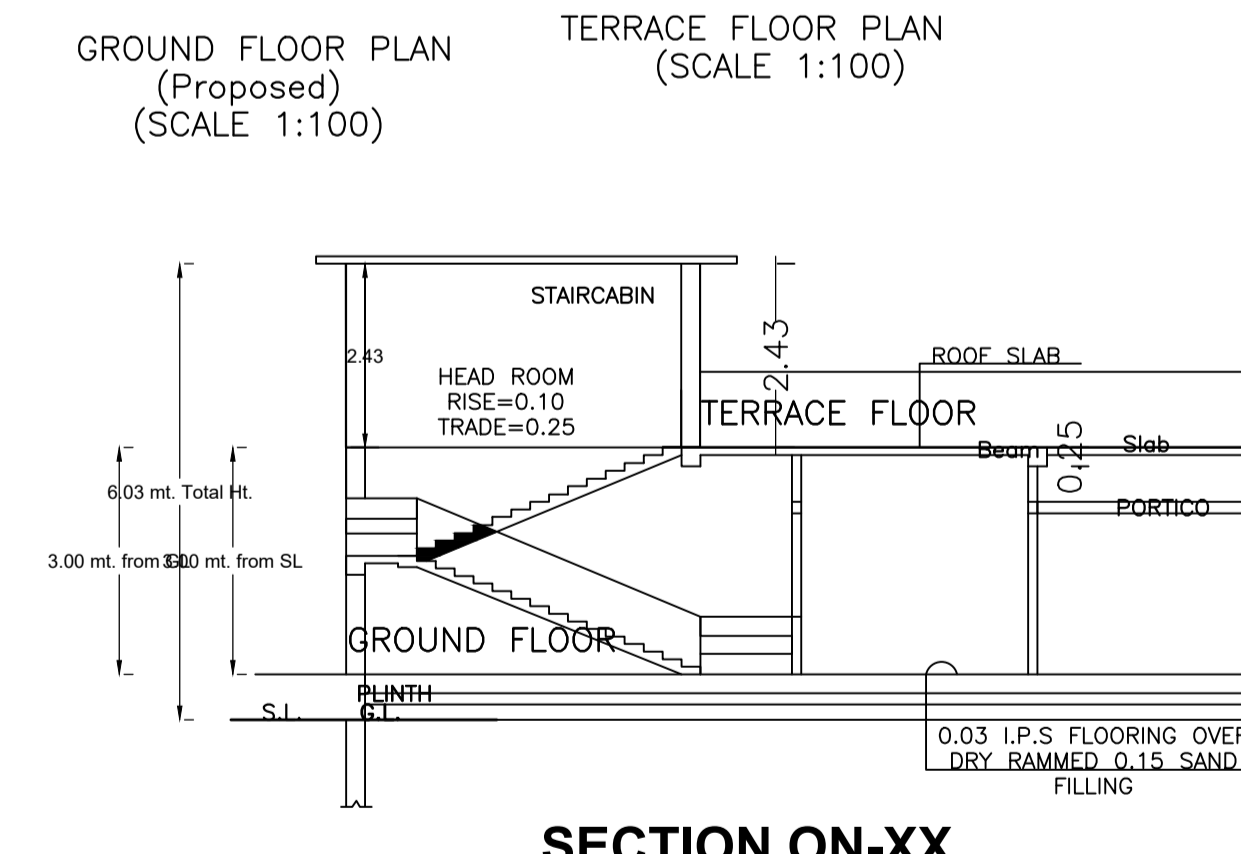
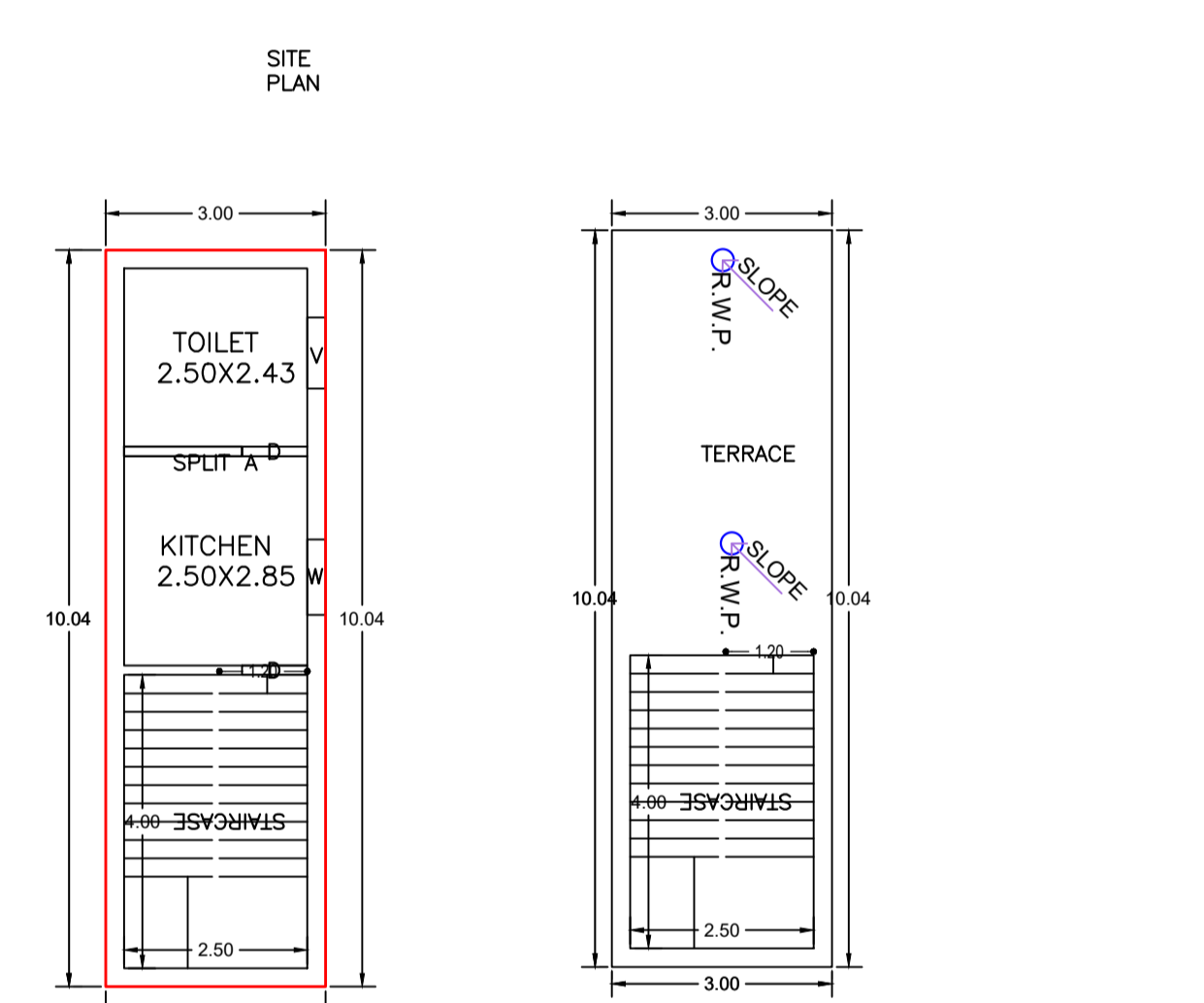
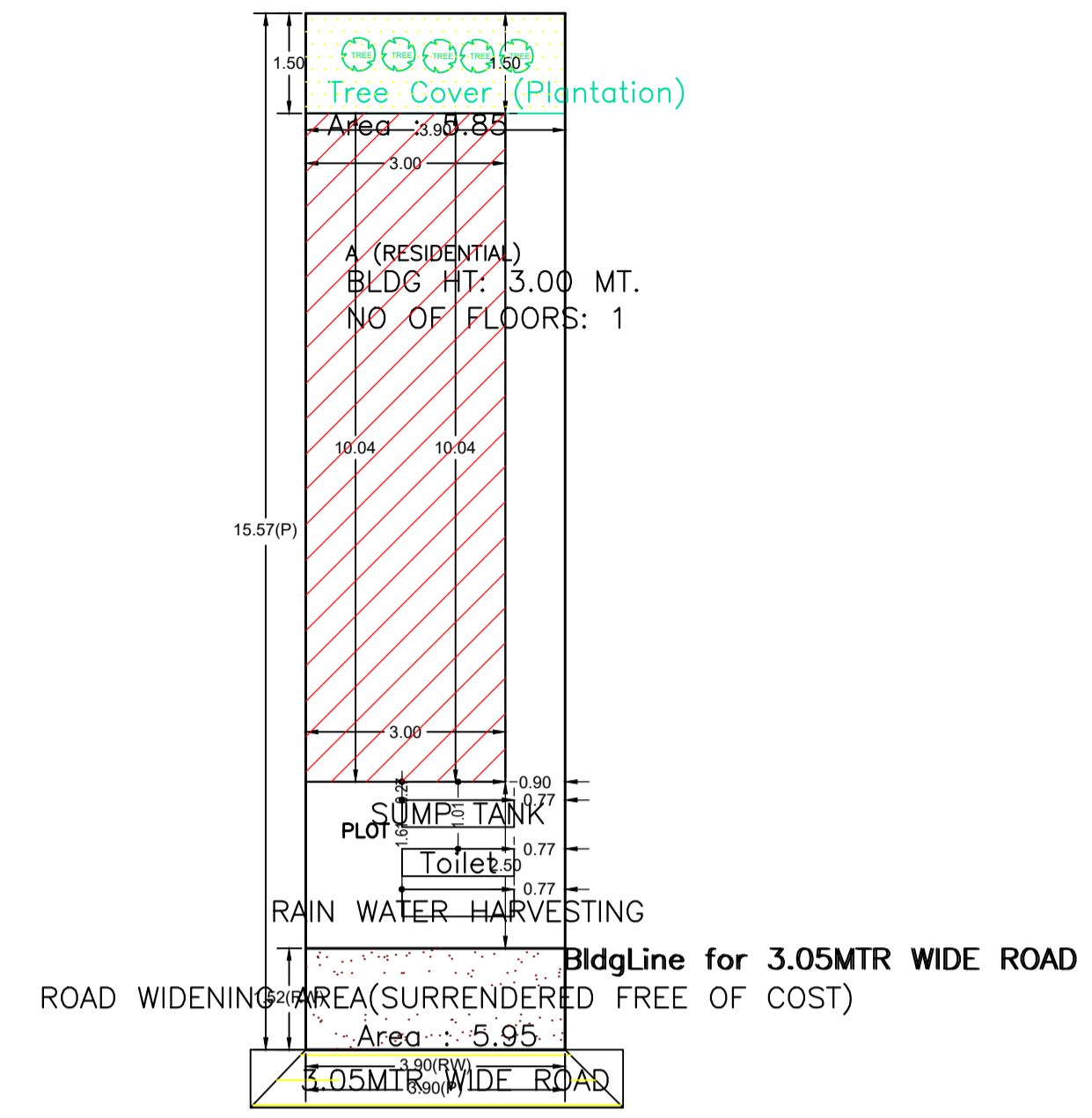

Buildingwise Floor FAR Details				
Floor Name	Building Name A (RESIDENTIAL)		Total	
	Proposed Built Up Area (Sq.mt.)	Proposed FAR Area (Sq.mt.)	Total Proposed Built Up Area (Sq.mt.)	Total FAR Area (Sq.mt.)
Ground Floor	30.13	30.13	30.13	30.13
Terrace Floor	0.00	0.00	0.00	0.00
Total :	30.13	30.13	30.13	30.13

Building USE/SUBUSE Details			
Building Name	Building Use	Building SubUse	Building Structure
A (RESIDENTIAL)	Residential	Bungalow/ Dwelling / Non Apartment	Non-Highrise

Building :A (RESIDENTIAL)					
Floor Name	Total Built Up Area (Sq.mt.)	Proposed FAR Area (Sq.mt.) Resi.	Total FAR Area (Sq.mt.)	Total Consumed Additional FAR Area (Sq.mt.)	Tnmt (No.)
Ground Floor	30.13	30.13	30.13	30.13	01
Terrace Floor	0.00	0.00	0.00	0.00	00
Total :	30.13	30.13	30.13	30.13	01
Total Number of Same Buildings	1				
Total :	30.13	30.13	30.13	30.13	01

SCHEDULE OF DOOR:				
BUILDING NAME	NAME	LENGTH	HEIGHT	NOS
A (RESIDENTIAL)	D	0.89	2.10	02
SCHEDULE OF WINDOW/VENTILATION:				
BUILDING NAME	NAME	LENGTH	HEIGHT	NOS
A (RESIDENTIAL)	V	0.97	0.60	01
A (RESIDENTIAL)	W	1.03	1.20	01

UnitBUA Table for Building :A (RESIDENTIAL)						
FLOOR	Name	UnitBUA Type	UnitBUA Area	Carpet Area	No. of Rooms	No. of Tenement
GROUND FLOOR PLAN	SPLIT A	FLAT	17.38	17.17	2	1
Total:	-	-	17.38	17.17	2	1

LTP NAME AND SIGNATURE	STRUCTURAL ENG'S NAME AND SIGNATURE	BUILDER NAME AND SIGNATURE	DIGITAL SIGNATURE
RANJIT KUMAR MNNP/ENG/0001/2016			