

Project Title :HARICHARAN SHUKLA

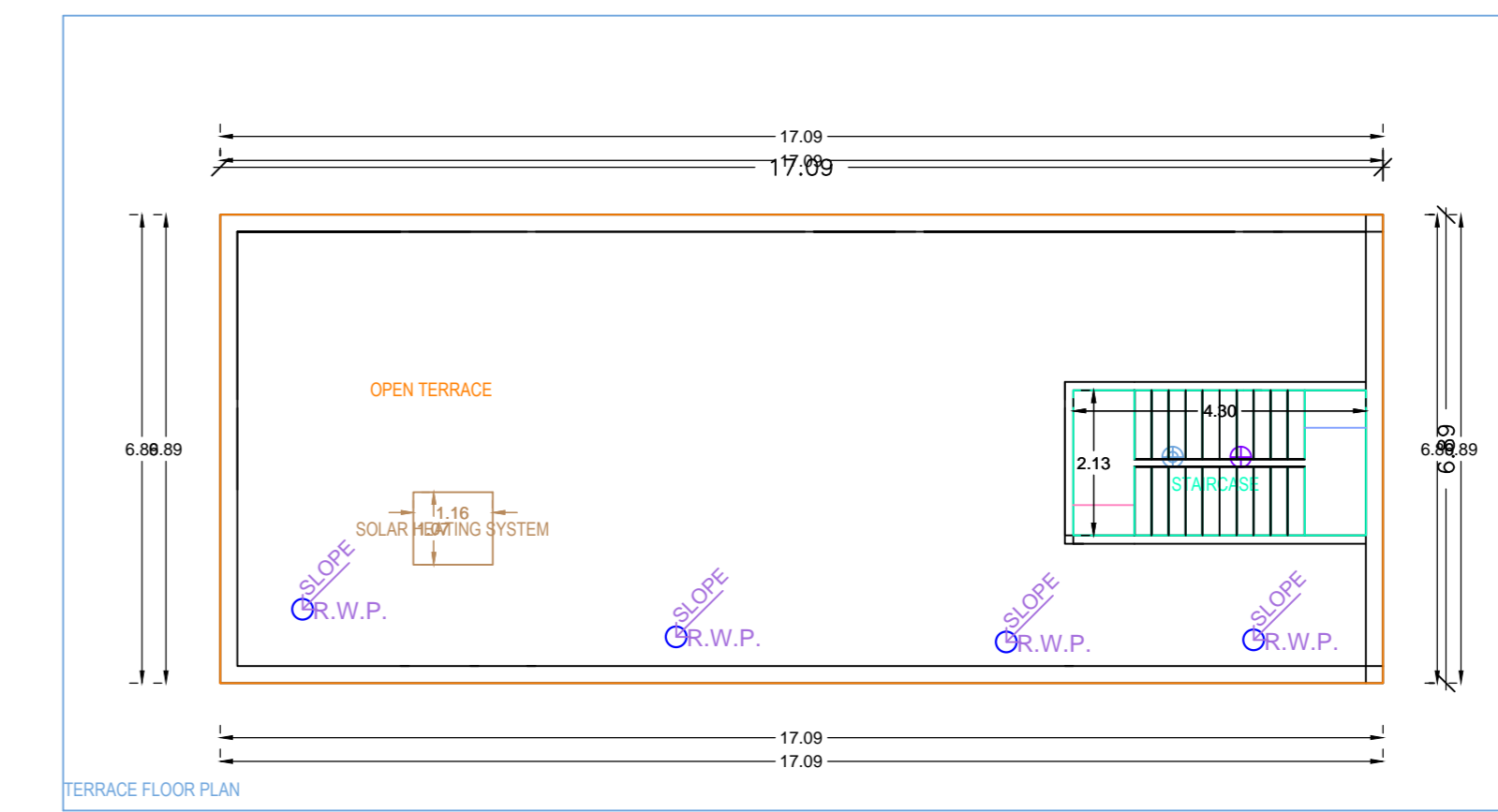
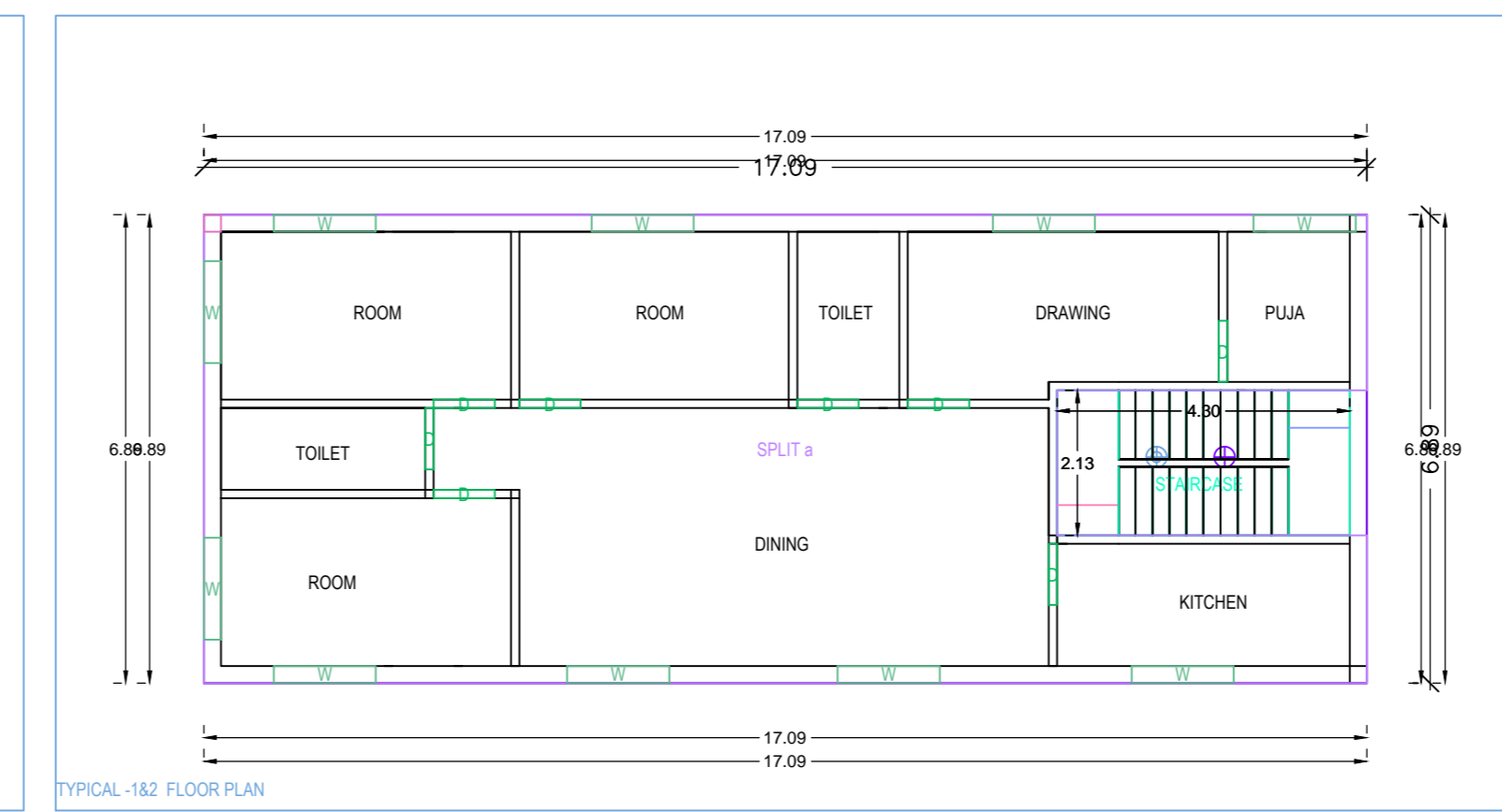
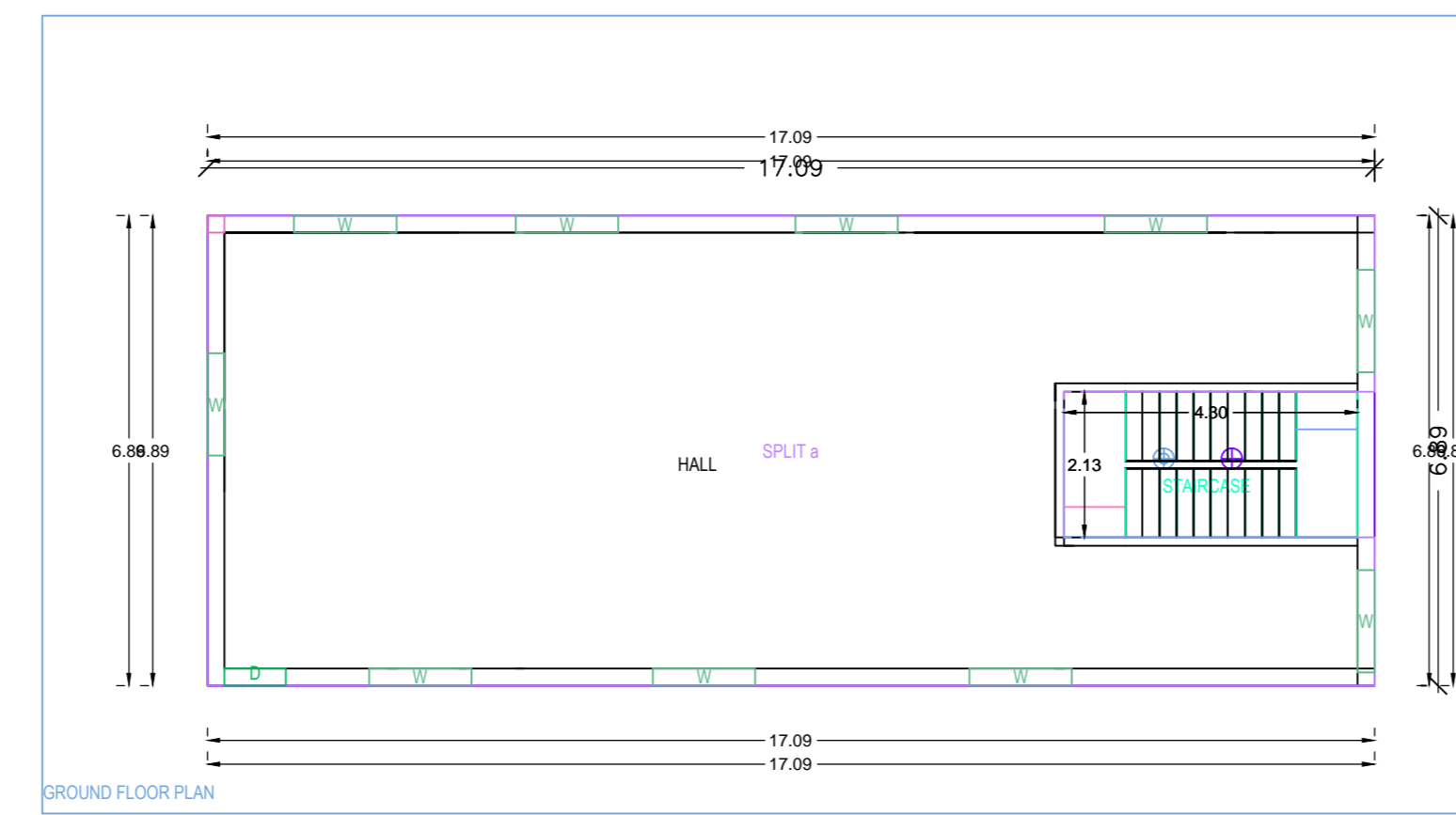
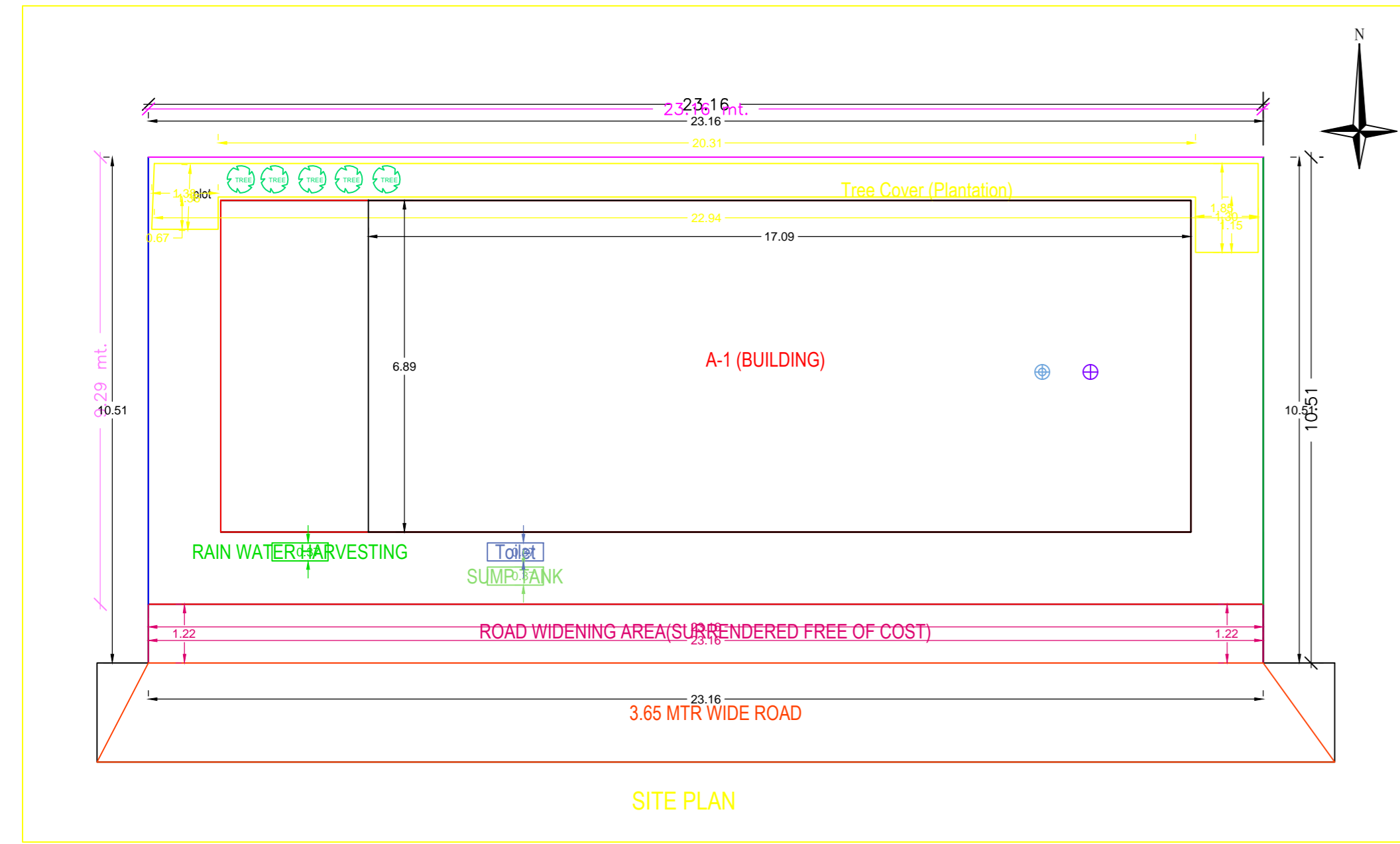
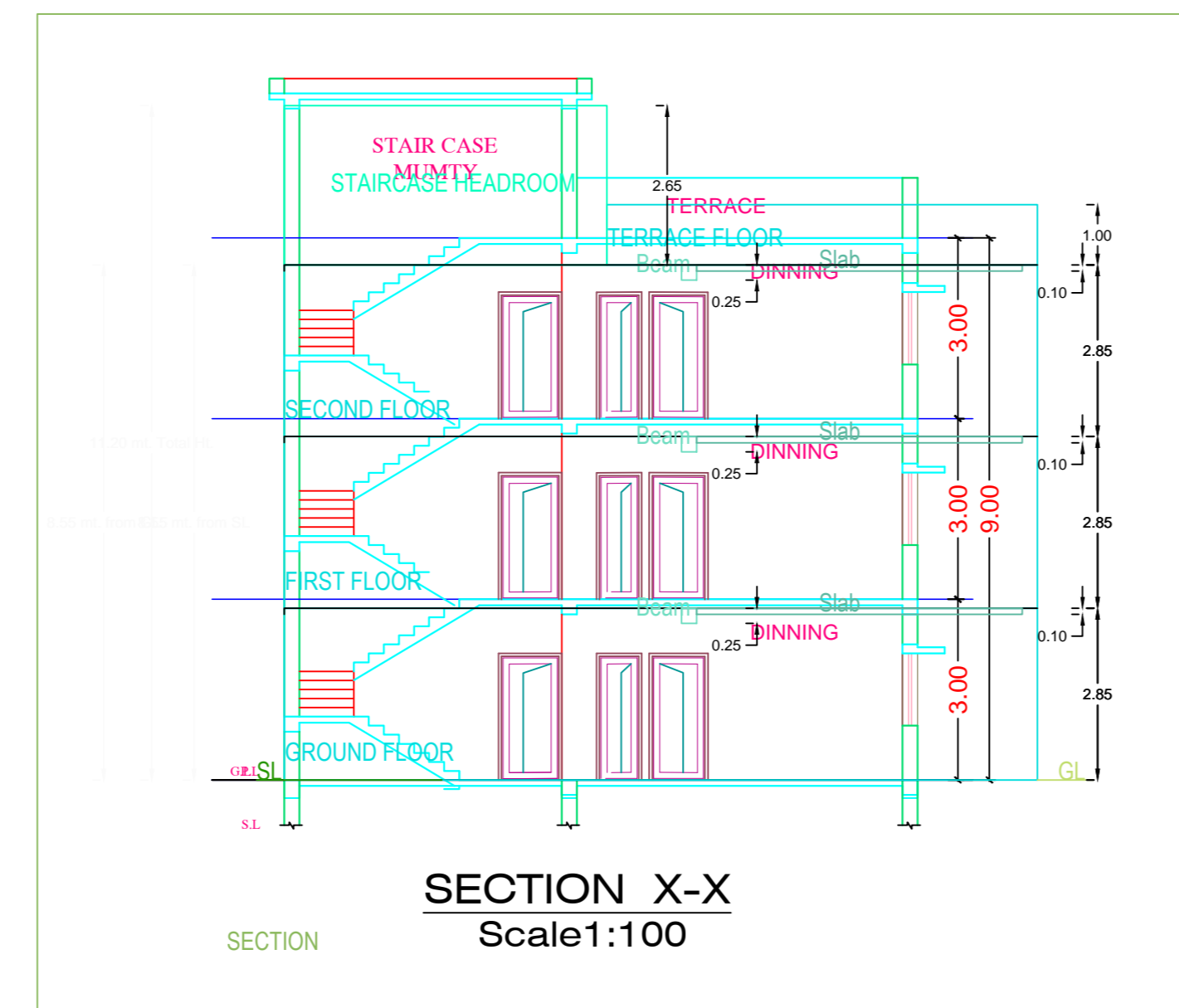
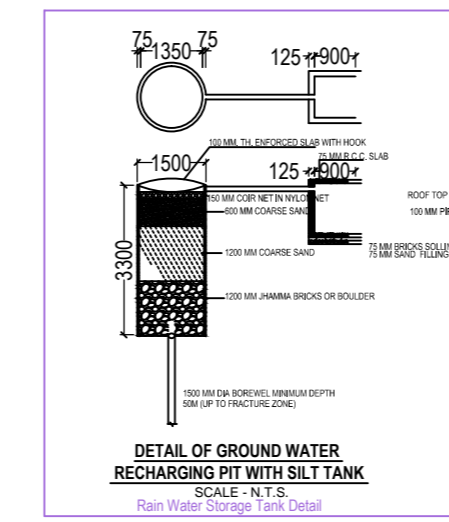
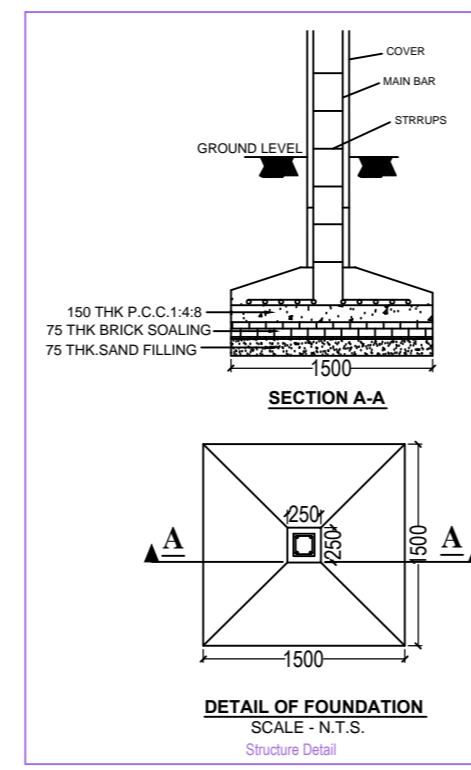
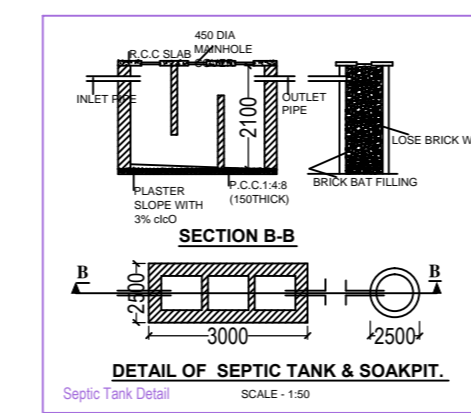
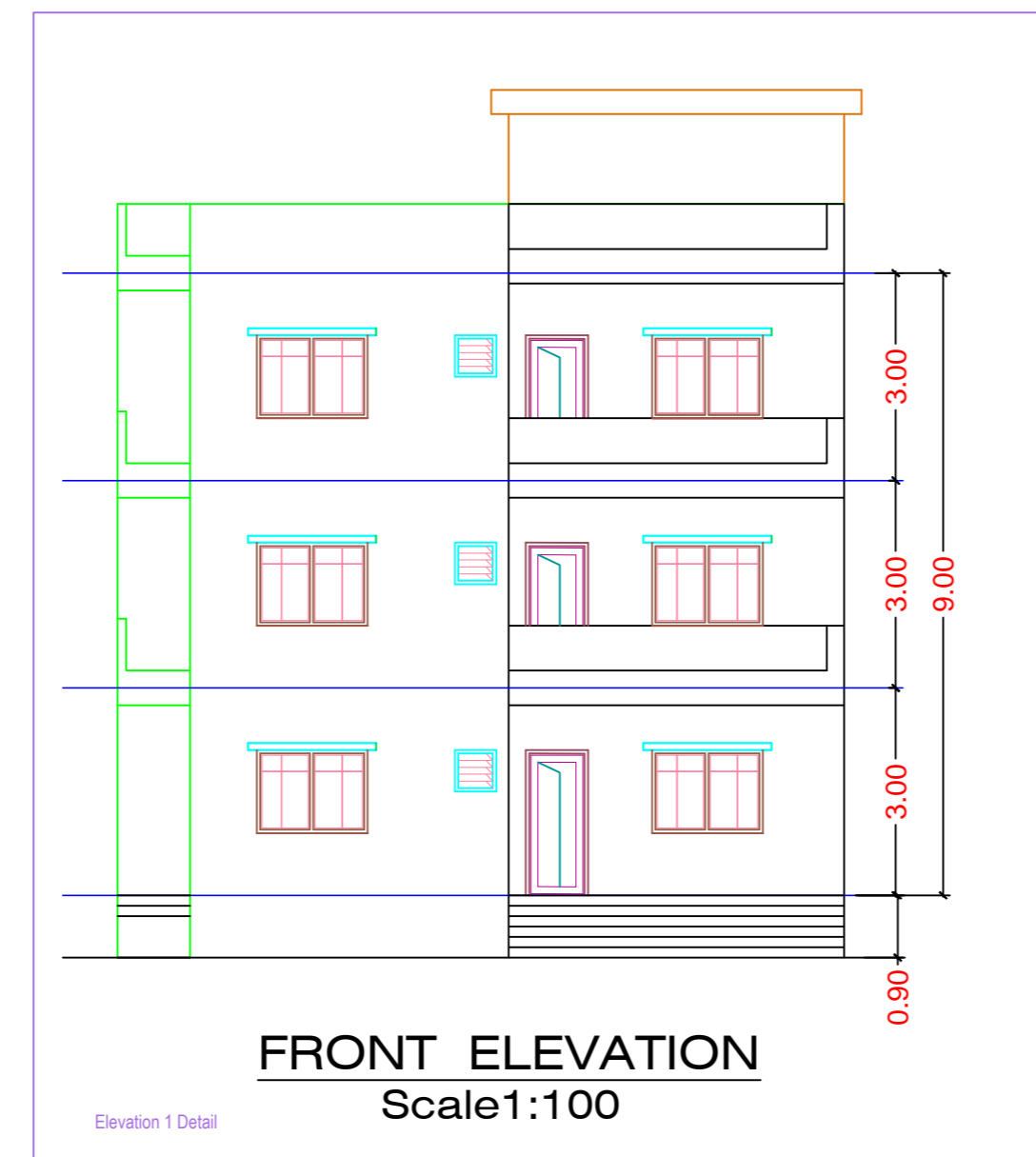

A (BUILDING)

Building A (BUILDING)

Floor Name	Total Built Up Area (Sq.mt.)	Proposed FAR Area (Sq.mt.)	Total FAR Area (Sq.mt.)	Trent (No.)
Ground Floor	117.75	117.75	117.75	01
First Floor	117.75	117.75	117.75	00
Second Floor	117.75	117.75	117.75	00
Terrace Floor	0.00	0.00	0.00	00
Total	353.25	353.25	353.25	01
Total Number of Same Buildings	1			
Total	353.25	353.25	353.25	01

SCHEDULE OF JOINERY:

BUILDING NAME	NAME	LENGTH	HEIGHT	NOS
A (BUILDING)	D	0.90	2.10	17
Total	-	-	-	17

SCHEDULE OF JOINERY:

BUILDING NAME	NAME	LENGTH	HEIGHT	NOS
A (BUILDING)	W	1.50	1.20	30
Total	-	-	-	30

UnitBUA Table for Building -A (BUILDING)

FLOOR	Name	UnitBUA Type	UnitBUA Area	Carpet Area	No. of Rooms	No. of Tenement
GROUND FLOOR PLAN	SPLIT #	FLAT	216.12	215.99	1	1
Total	-	-	216.12	215.99	21	1

AREA STATEMENT: MEDINAGAR MUNICIPAL CORPORATION	VERSION NO: 1.0/37
PROJECT DETAIL:	VERSION DATE: 16/10/2020
Tenant: -	Plot Use: Residential
Region: #HAROHARI URBAN LOCAL BODIES	Plot Size/Use: Bungalow/Dwelling / Non Apartment
District: PALAKKAD	Land Use Zone: NA
Application Type: General Proposal	Absolute Road Width: -
Project Type: Building Permission	Plot No.: -
Nature of Development: New	Revenue Survey No/Survey No: -
Location: Old Area	Thana No: -
Sub Location: NA	Holding No: -
Village/Moza Name: -	Khata No: -
Ward No: -	North: -
Road/Street: -	South: -
	East: -
	West: -

AREA DETAILS:	(A)	SQ.MT.
AREA OF PLOT (Minimum)		243.41
Deduction for Half Plot Area		28.26
Summative Free of Cost		28.26
Total		215.16
Net Plot Area (Gross Plot Area - Deduction from Gross Plot Area)	(A-Deductions)	215.16
Deductions for Balance Plot Area (from Gross Plot Area)		28.26
Free Gross Plot Area		18.39
COP Area		46.65
Total		156.76
Balance Plot Area (Net Plot Area - Recreational/Amenity space)	(A-Deductions)	156.76
Plot Area for Coverage (Net Plot Area - Road/Mosque Area)	(A-Deductions)	215.16
Plot Area for FSI (Net Plot Area - Road/Mosque Area)	(A-Deductions)	243.41
Accessory/Use Area		0.44
COVERAGE CHECK		
Proposed Coverage Area (54.73 %)		117.75
Total Coverage Area (54.73 %)		117.75
FAR CHECK		
Proposed Area of FAR		353.25
TGM Area of FAR		353.25
BUILT UP AREA CHECK		
Total Proposed Built Up Area		353.25
ARCHT/ENGRG/SUPERVISOR (Regdt)		OWNER
DEVELOPMENT AUTHORITY		LOCAL BODY

COLOR INDEX	
Plot Boundary	Green
Abutting Road	Red
Proposed Work (Coverage Area)	Blue
Existing (To be retained)	Yellow
Existing (To be demolished)	Black

Color Index:	MARGIN DETAIL:				
Building / Wing Name	Road Name	Front Margin	Rear Margin	Side1 Margin	Side2 Margin
A-1 (BUILDING)	ROAD WIDENING AREAS (PROPOSED FREE OF COST)	1.50	0.90	4.57	1.50

FAR & Tenement Details (Table 4c-1)					
Building	No. of Same Bldg	Total Built Up Area (Sq.mt.)	Proposed FAR Area (Sq.mt.)	Total FAR Area (Sq.mt.)	Trent (No.)
A (BUILDING)	1	353.25	353.25	353.25	01
Grand Total:	1	353.25	353.25	353.25	01