

SITE PLAN

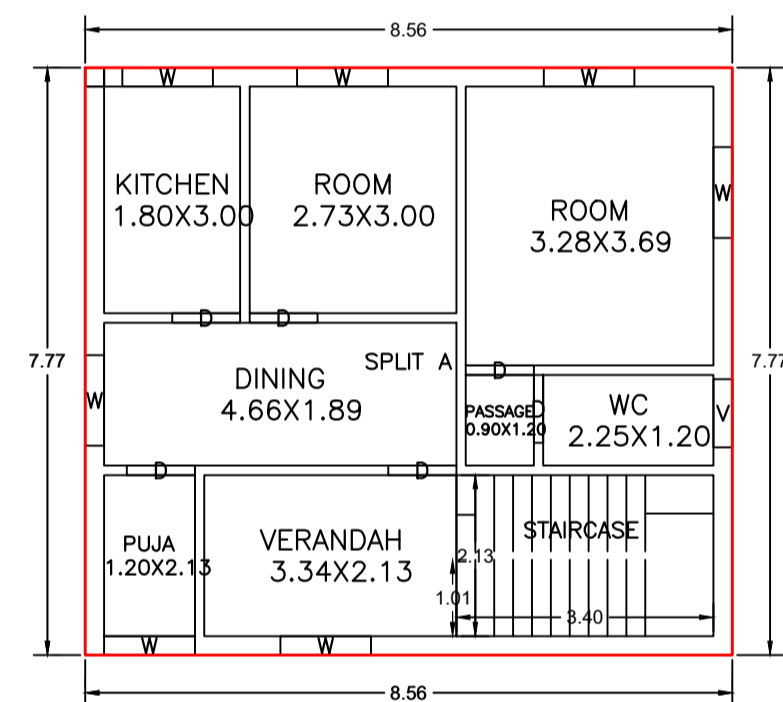

GROUND FLOOR PLAN (Proposed) (SCALE 1:100)

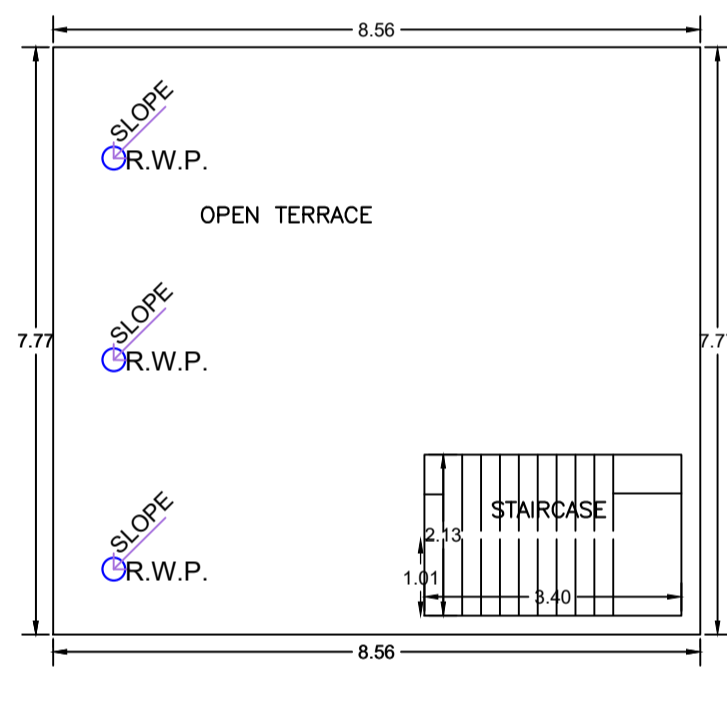

TERRACE FLOOR PLAN (SCALE 1:100)

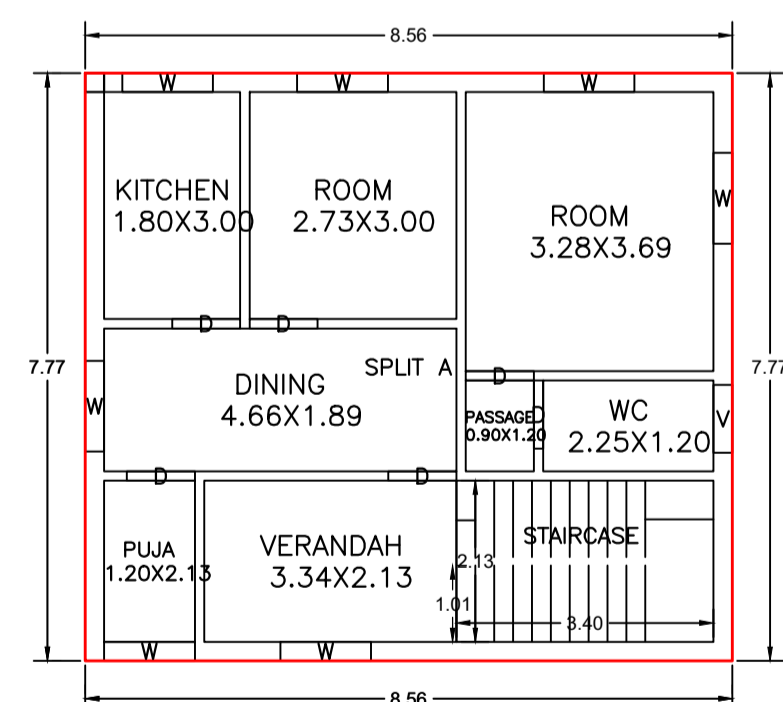

FIRST FLOOR PLAN (Proposed) (SCALE 1:100)

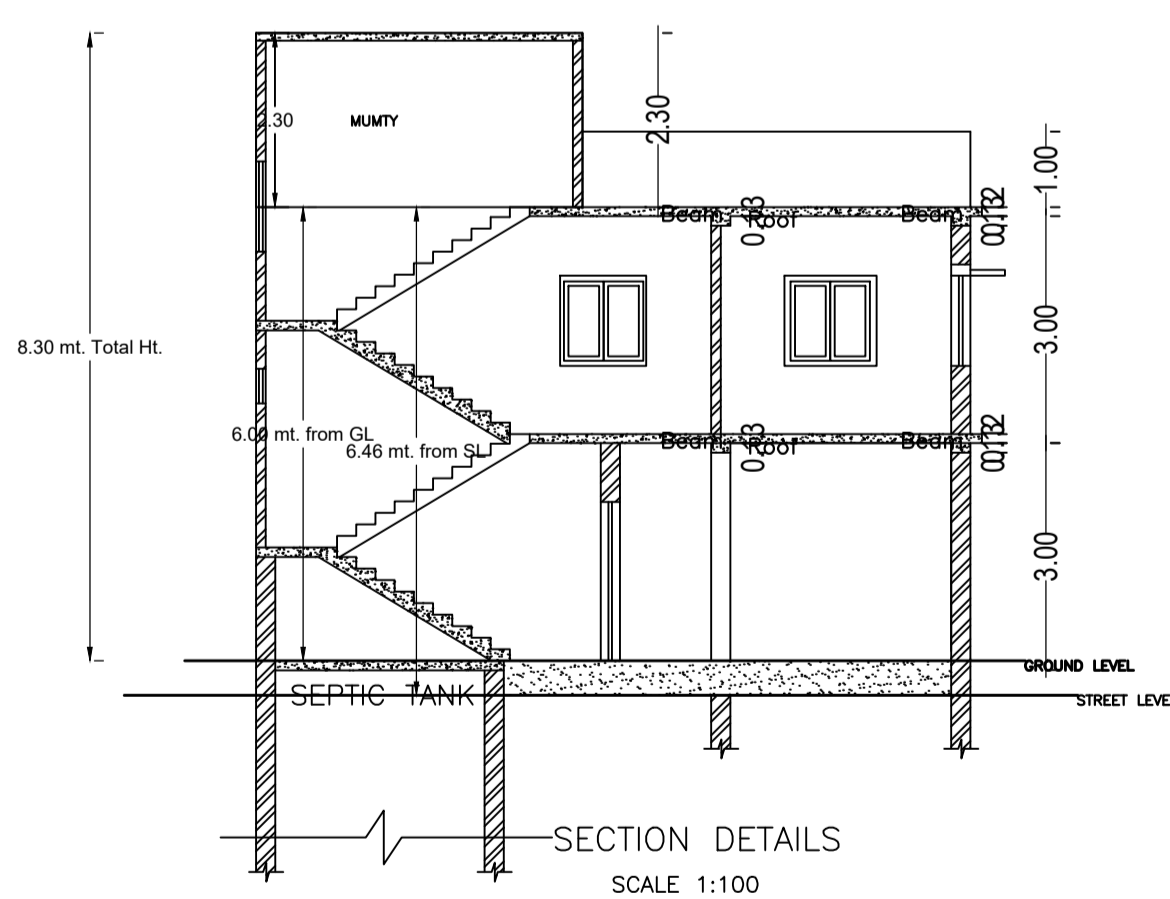

SECTION DETAILS (SCALE 1:100)

Building :A (BUILDING)

Floor Name	Total Built Up Area (Sq.mt.)	Proposed FAR Area (Sq.mt.) Resi.	Total FAR Area (Sq.mt.)	Total Consumed Additional FAR Area (Sq.mt.)	Tnmt (No.)
Ground Floor	66.51	66.51	66.51	66.51	01
First Floor	66.51	66.51	66.51	66.51	00
Terrace Floor	0.00	0.00	0.00	0.00	00
Total :	133.02	133.02	133.02	133.02	01
Total Number of Same Buildings	1				
Total :	133.02	133.02	133.02	133.02	01

SCHEDULE OF DOOR:

BUILDING NAME	NAME	LENGTH	HEIGHT	NOS
A (BUILDING)	D	0.90	2.10	12

SCHEDULE OF WINDOW/VENTILATION:

BUILDING NAME	NAME	LENGTH	HEIGHT	NOS
A (BUILDING)	V	0.90	0.60	02
A (BUILDING)	W	1.20	1.20	14

UnitBUA Table for Building :A (BUILDING)

FLOOR	Name	UnitBUA Type	UnitBUA Area	Carpet Area	No. of Rooms	No. of Tenement
GROUND FLOOR PLAN	SPLIT A	FLAT	115.65	115.52	8	1
FIRST FLOOR PLAN	SPLIT A	FLAT	0.00	0.00	8	0
Total:	-	-	115.65	115.52	16	1

FAR & Tenement Details (Table 4c-1)

Building	No. of Same Bldg	Total Built Up Area (Sq.mt.)	Proposed FAR Area (Sq.mt.) Resi.	Total FAR Area (Sq.mt.)	Total Consumed Additional FAR Area (Sq.mt.)	Tnmt (No.)
A (BUILDING)	1	133.02	133.02	133.02	133.02	01
Grand Total :	1	133.02	133.02	133.02	133.02	01

Proposal Basic Information

Proposal File No.	MNNP/BI/0076/W06/2024
Owner Name	KANTI DEVI
Khata No	284
Plot No	922
Village Name	Baralota
Use	Residential
SubUse	Bungalow/ Dwelling / Non Apartment

AREA STATEMENT		VERSION NO. : 1.0.69
MEDININAGAR MUNICIPAL CORPORATION		VERSION DATE: 16/10/2020
PROJECT DETAIL:		
Region: JHARKHAND URBAN LOCAL BODIES	Plot Use: Residential	
District: PALAMU	Plot SubUse: Bungalow/ Dwelling / Non Apartment	
Authority: MEDININAGAR MUNICIPAL CORPORATION	PlotNearby/Religious/Structure: NA	
Inward No: MNNP/BI/0076/W06/2024	Plot/SubPlot No: 922	
Application Type: General Proposal	North: -	
Project Type: Building Permission	South: -	
Nature of Development: New	East: -	
Location of Development Area: New Area	West: -	
AREA DETAILS:		
AREA OF PLOT (Minimum)	(A)	140.48
Deduction for NetPlot Area		
Surrender Free of Cost		23.72
Total		23.72
NET AREA OF PLOT(Gross Plot Area - Deduction from Gross Plot area)		
(A-Deductions)		116.76
Deduction for Balance Plot Area(from Gross Plot Area)		
Surrender Free of Cost		23.72
Common Plot		14.72
Total		38.44
BALANCE AREA OF PLOT(Net Plot Area - Recreational/Amenity space)		
(A-Deductions)		102.04
PLOT AREA FOR COVERAGE(Net Plot Area)		
(A-Deductions)		116.76
Plot Area for FAR (Net Plot Area + Road/Widening Area)		
(A-Deductions)		140.48
COVERAGE CHECK		
Permissible Coverage area ( 70.00 % )		81.73
Proposed Coverage Area ( 56.96 % )		66.51
Total Prop. Coverage Area ( 56.96 % )		66.51
Balance coverage area ( 13.04 % )		15.22
FAR CHECK		
Perm. FAR Area ( 1.500 )		210.72
Total Perm. FAR area		210.72
Residential FAR		133.02
Proposed FAR Area		133.02
Total Proposed FAR Area		133.02
Consumed FAR (Factor)		0.95
Balance FAR Area		77.70
BUILT UP AREA CHECK		
Total Proposed BuiltUp Area		133.02
ARCHITECT (Regd)	AKASH SRIVASTAVA	
ENGINEER (Regd)		
SUPERVISOR (Regd)		
OWNER (Regd)	KANTI DEVI	
DEVELOPMENT AUTHORITY		LOCAL BODY

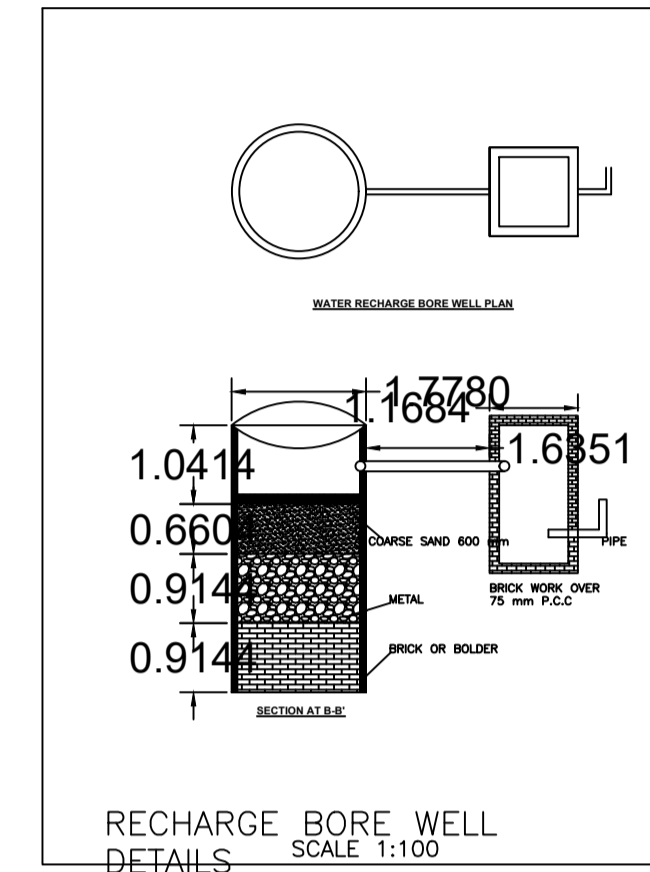

RECHARGE BORE WELL DETAILS (SCALE 1:100)

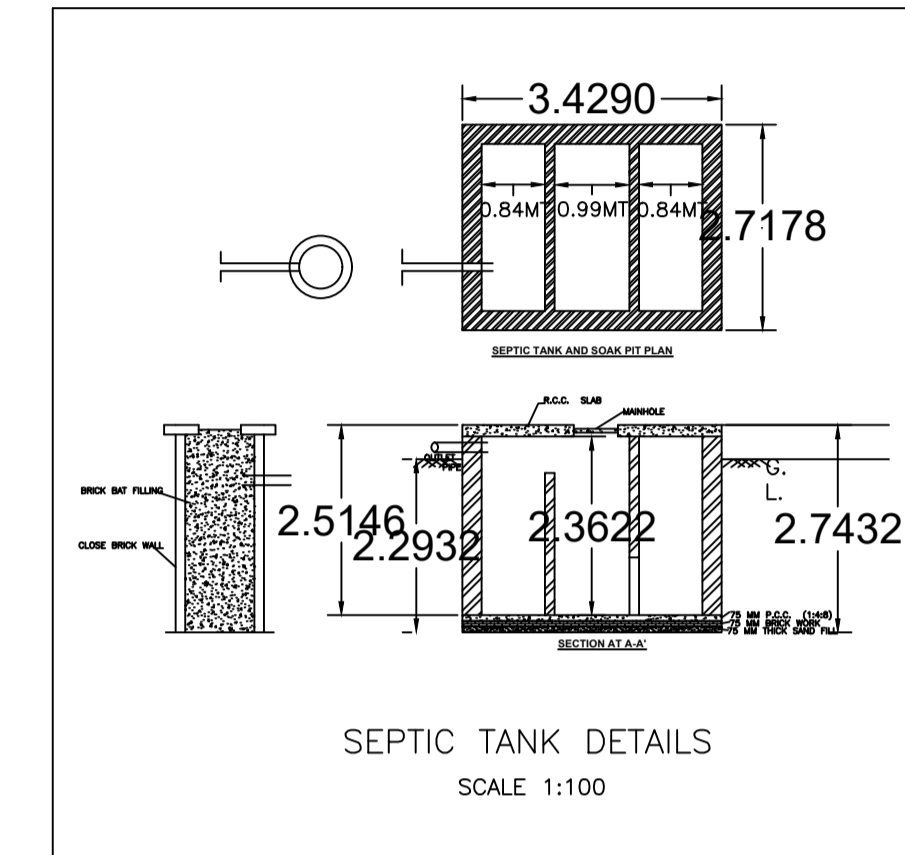

SEPTIC TANK DETAILS (SCALE 1:100)

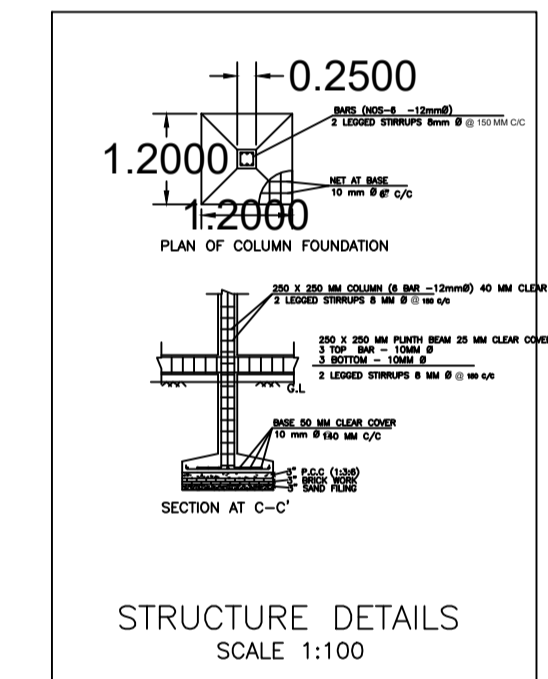

STRUCTURE DETAILS (SCALE 1:100)

COLOR INDEX	
PLOT BOUNDARY	Black
ABUTTING ROAD	Green
PROPOSED CONSTRUCTION	Red
COMMON PLOT	Yellow
ROAD WIDENING AREA	Blue
EXISTING (To be retained)	Orange
EXISTING (To be demolished)	White

Buildingwise Floor FAR Details

Floor Name	Building Name A (BUILDING)		Total	
	Proposed Built Up Area (Sq.mt.)	Proposed FAR Area (Sq.mt.)	Total Proposed Built Up Area (Sq.mt.)	Total FAR Area (Sq.mt.)
Ground Floor	66.51	66.51	66.51	66.51
First Floor	66.51	66.51	66.51	66.51
Terrace Floor	0.00	0.00	0.00	0.00
Total :	133.02	133.02	133.02	133.02

Building USE/SUBUSE Details

Building Name	Building Use	Building SubUse	Building Structure
A (BUILDING)	Residential	Bungalow/ Dwelling / Non Apartment	Non-Highrise

LTP NAME AND SIGNATURE	STRUCTURAL ENG'S NAME AND SIGNATURE	BUILDER NAME AND SIGNATURE	DIGITAL SIGNATURE
AKASH SRIVASTAVA MNNP/ENG/0009/2021			