

SITE PLAN

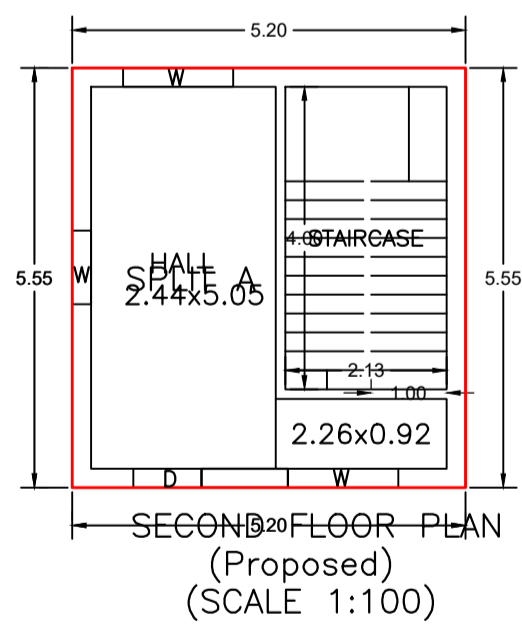
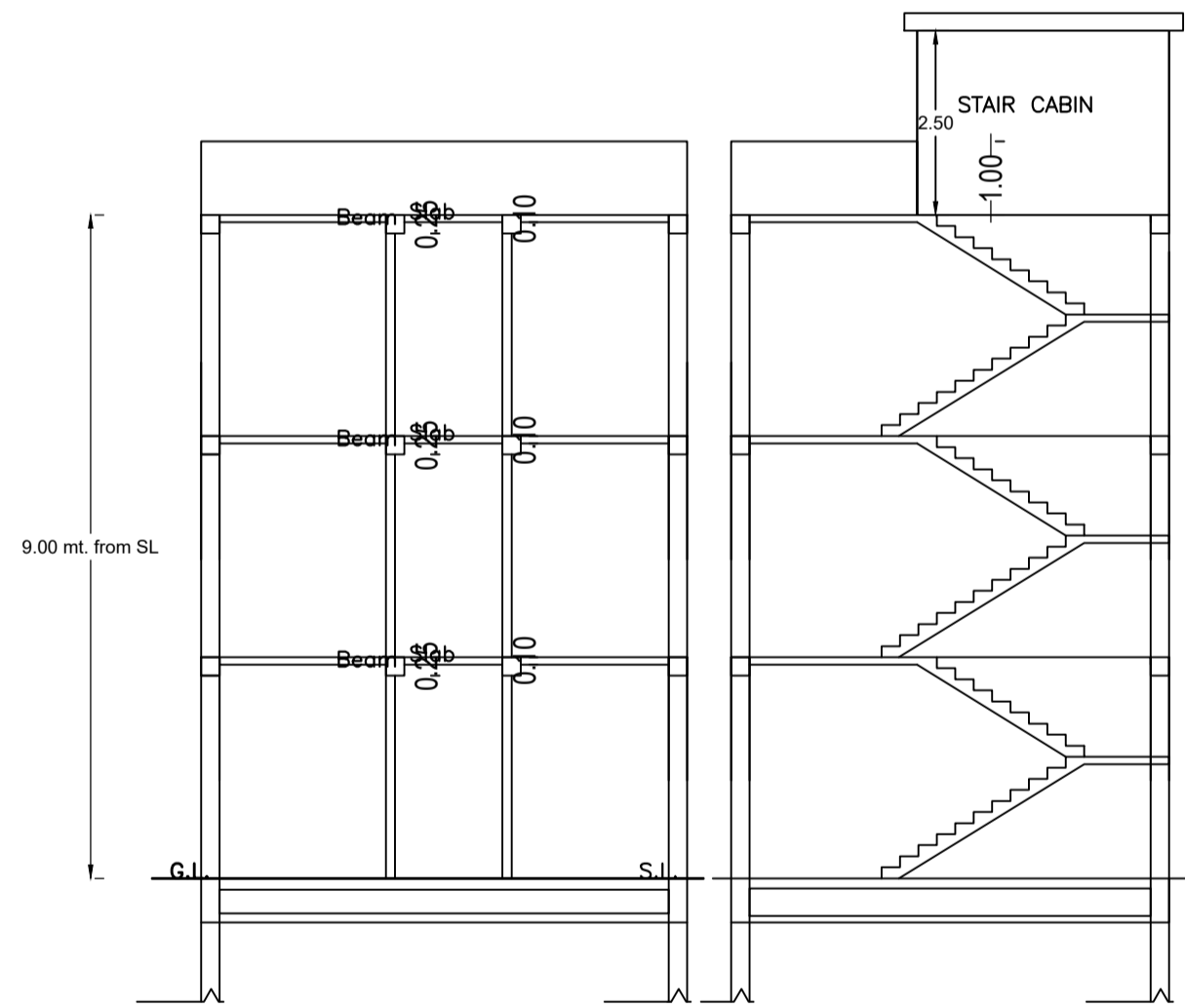
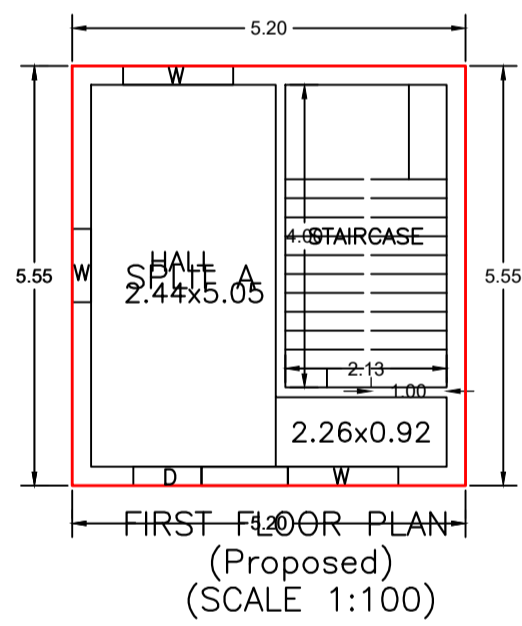
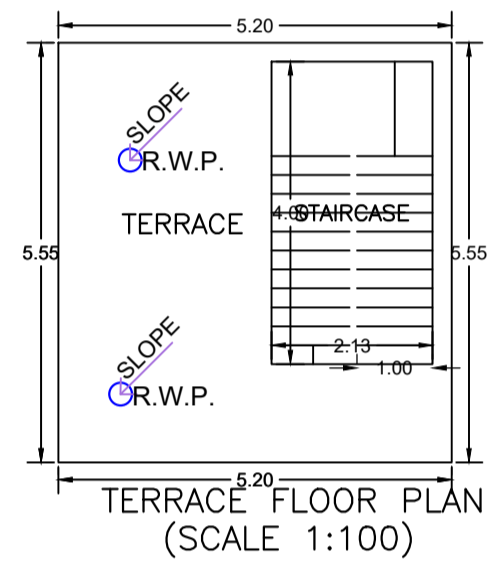
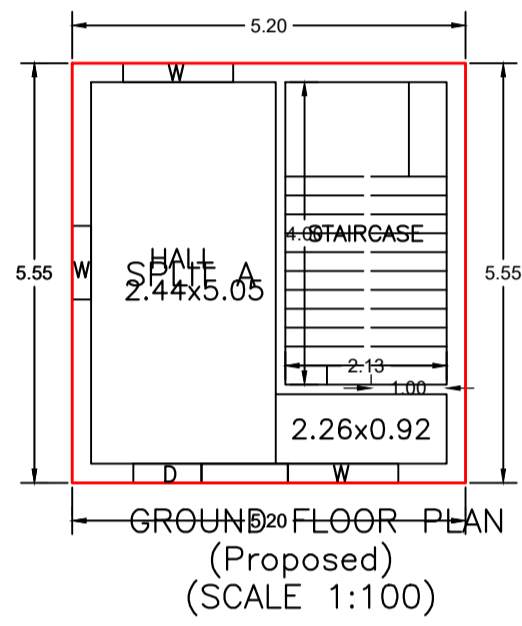

Building :A (RESIDENTIAL)

Floor Name	Total Built Up Area (Sq.mt.)	Proposed FAR Area (Sq.mt.) Resi.	Total FAR Area (Sq.mt.)	Total Consumed Additional FAR Area (Sq.mt.)	Tnmt (No.)
Ground Floor	28.86	28.86	28.86	28.86	01
First Floor	28.86	28.86	28.86	28.86	00
Second Floor	28.86	28.86	28.86	28.86	00
Terrace Floor	0.00	0.00	0.00	0.00	00
Total :	86.58	86.58	86.58	86.58	01
Total Number of Same Buildings	1				
Total :	86.58	86.58	86.58	86.58	01

SCHEDULE OF DOOR:

BUILDING NAME	NAME	LENGTH	HEIGHT	NOS
A (RESIDENTIAL)	D	0.90	2.10	03

SCHEDULE OF WINDOW/VENTILATION:

BUILDING NAME	NAME	LENGTH	HEIGHT	NOS
A (RESIDENTIAL)	W	0.97	1.20	03
A (RESIDENTIAL)	W	1.46	1.20	06

UnitBUA Table for Building :A (RESIDENTIAL)

FLOOR	Name	UnitBUA Type	UnitBUA Area	Carpet Area	No. of Rooms	No. of Tenement
GROUND FLOOR PLAN	SPLIT A	FLAT	56.23	55.37	1	1
FIRST FLOOR PLAN	SPLIT A	FLAT	0.00	0.00	1	0
SECOND FLOOR PLAN	SPLIT A	FLAT	0.00	0.00	1	0
Total:	-	-	56.23	55.37	3	1

FAR & Tenement Details (Table 4c-1)

Building	No. of Same Bldg	Total Built Up Area (Sq.mt.)	Proposed FAR Area (Sq.mt.) Resi.	Total FAR Area (Sq.mt.)	Total Consumed Additional FAR Area (Sq.mt.)	Tnmt (No.)
A (RESIDENTIAL)	1	86.58	86.58	86.58	86.58	01
Grand Total :	1	86.58	86.58	86.58	86.58	01

Proposal Basic Information

Proposal File No.	MNNP/IBP/0097/W06/2024
Owner Name	VITU VERMA
Khata No	123
Plot No	1783
Village Name	Baralota
Use	Residential
SubUse	Bungalow/ Dwelling / Non Apartment

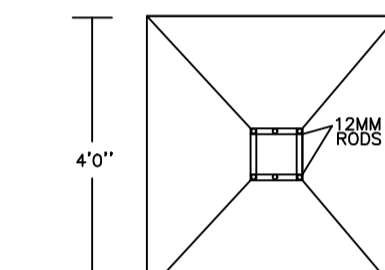
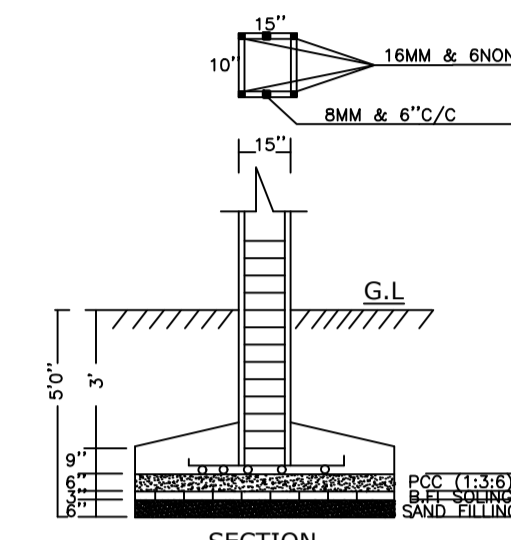

AREA STATEMENT		VERSION NO. : 1.0.70
MEDININAGAR MUNICIPAL CORPORATION		VERSION DATE: 16/10/2020
PROJECT DETAIL:		
Region: JHARKHAND URBAN LOCAL BODIES	Plot Use: Residential	
District: PALAMU	Plot SubUse: Bungalow/ Dwelling / Non Apartment	
Authority: MEDININAGAR MUNICIPAL CORPORATION	PlotNearbyReligiousStructure: NA	
Inward No: MNNP/IBP/0097/W06/2024	Plot/SubPlot No: 1783	
Application Type: General Proposal	North: -	
Project Type: Building Permission	South: -	
Nature of Development: New	East: -	
Location of Development Area: Old Area	West: -	
AREA DETAILS:		
AREA OF PLOT (Minimum)	(A)	SQ.MT. 61.31
NET AREA OF PLOT(Gross Plot Area - Deduction from Gross Plot area)	(A-Deductions)	61.31
Deduction for Balance Plot Area(from Gross Plot Area)		
Common Plot		12.20
Total		12.20
BALANCE AREA OF PLOT(Net Plot Area - Recreational/Amenity space)	(A-Deductions)	49.11
PLOT AREA FOR COVERAGE(Net Plot Area)	(A-Deductions)	61.31
Plot Area for FAR (Net Plot Area + Road/Widening Area)	(A-Deductions)	61.31
COVERAGE CHECK		
Permissible Coverage area (70.00 %)		42.92
Proposed Coverage Area (47.08 %)		28.86
Total Prop. Coverage Area (47.08 %)		28.86
Balance coverage area (22.93 %)		14.06
FAR CHECK		
Perm. FAR Area (2.500)		153.28
Total Perm. FAR area		153.28
Residential FAR		86.58
Proposed FAR Area		86.58
Total Proposed FAR Area		86.58
Consumed FAR (Factor)		1.41
Balance FAR Area		66.70
BUILT UP AREA CHECK		
Total Proposed BuiltUp Area		86.58
ARCHITECT (Regd)	RANJIT KUMAR	
ENGINEER (Regd)		
SUPERVISOR (Regd)		
OWNER (Regd)	VITU VERMA	
DEVELOPMENT AUTHORITY		LOCAL BODY

COLOR INDEX	
PLOT BOUNDARY	[Red Line]
ABUTTING ROAD	[Green Line]
PROPOSED CONSTRUCTION	[Blue Line]
COMMON PLOT	[Yellow Line]
ROAD WIDENING AREA	[Orange Line]
EXISTING (To be retained)	[Light Blue Line]
EXISTING (To be demolished)	[Light Yellow Line]

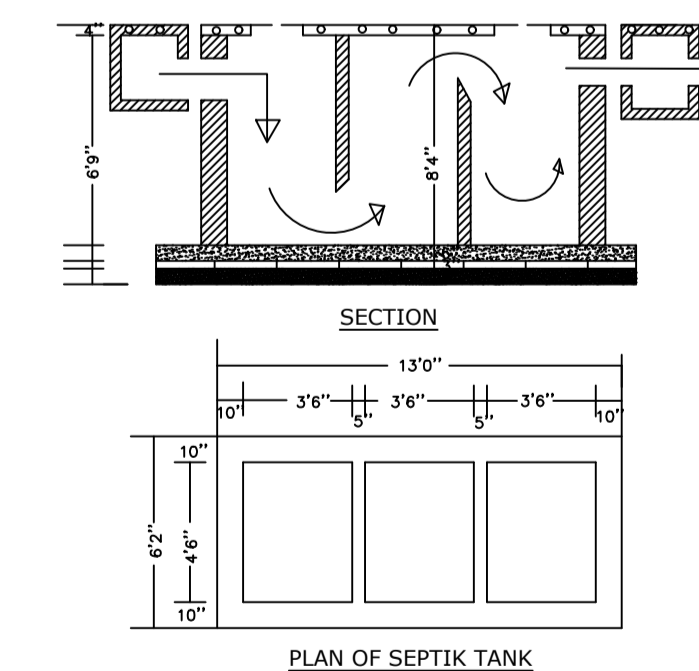

Buildingwise Floor FAR Details

Floor Name	Building Name A (RESIDENTIAL)		Total	
	Proposed Built Up Area (Sq.mt.)	Proposed FAR Area (Sq.mt.)	Total Proposed Built Up Area (Sq.mt.)	Total FAR Area (Sq.mt.)
Ground Floor	28.86	28.86	28.86	28.86
First Floor	28.86	28.86	28.86	28.86
Second Floor	28.86	28.86	28.86	28.86
Terrace Floor	0.00	0.00	0.00	0.00
Total :	86.58	86.58	86.58	86.58

Building USE/SUBUSE Details

Building Name	Building Use	Building SubUse	Building Structure
A (RESIDENTIAL)	Residential	Bungalow/ Dwelling / Non Apartment	Non-Highrise

LTP NAME AND SIGNATURE	STRUCTURAL ENG'S NAME AND SIGNATURE	BUILDER NAME AND SIGNATURE	DIGITAL SIGNATURE
RANJIT KUMAR MNNP/ENG/0001/2016			