

FAR & Tenement Details (Table 4c-1)

Building	No. of Same Bldg	Total Built Up Area (Sq.mt.)	Proposed FAR Area (Sq.mt.) Resi.	Total FAR Area (Sq.mt.)	Total Consumed Additional FAR Area (Sq.mt.)	Tnmt (No.)
A (RESIDENTIAL)	1	179.34	179.34	179.34	179.34	01
Grand Total :	1	179.34	179.34	179.34	179.34	01

Proposal Basic Information

Proposal File No.	MNNP/BP/0095/W03/2024
Owner Name	LALITA DEVI
Khata No	44
Plot No	305
Village Name	Sudma Bariya
Use	Residential
SubUse	Bungalow Dwelling / Non Apartment

AREA STATEMENT

MEDINAGAR MUNICIPAL CORPORATION	VERSION NO. : 1.0.70
PROJECT DETAIL:	VERSION DATE: 16/10/2020
Region : JHARKHAND URBAN LOCAL BODIES	Plot Use: Residential
District: PALAMU	Plot SubUse: Bungalow Dwelling / Non Apartment
Authority: MEDINAGAR MUNICIPAL CORPORATION	PlotNearbyReligiousStructure: NA
Inward No: MNNP/BP/0095/W03/2024	Plot/SubPlot No: 305
Application Type: General Proposal	North: -
Project Type: Building Permission	South: -
Nature of Development: New	East: -
Location of Development Area: New	West: -
AREA OF PLOT (Minimum)	SQ.MT.
Area	182.17
Deduction for NetPlot Area	
Surrender Free of Cost	11.96
Total	11.96
NET AREA OF PLOT(Gross Plot Area - Deduction from Gross Plot area)	(A-Deductions)
Area	170.21
Deduction for Balance Plot Area(from Gross Plot Area)	
Surrender Free of Cost	11.96
Common Plot	16.45
Total	28.42
BALANCE AREA OF PLOT(Net Plot Area - Recreational/Amenity space)	(A-Deductions)
Area	153.76
PLOT AREA FOR COVERAGE(Net Plot Area)	(A-Deductions)
Area	170.21
Plot Area for FAR (Net Plot Area + Road Widening Area)	(A-Deductions)
Area	182.17
COVERAGE CHECK	
Permissible Coverage area ( 70.00 % )	119.15
Proposed Coverage Area ( 52.68 % )	89.67
Total Prop. Coverage Area ( 52.68 % )	89.67
Balance coverage area ( 17.32 % )	29.48
FAR CHECK	
Perm. FAR Area ( 1.500 )	273.26
Total Perm. FAR area	273.26
Residential FAR	179.35
Proposed FAR Area	179.35
Total Proposed FAR Area	179.35
Consumed FAR (Factor)	0.98
Balance FAR Area	93.91
BUILT UP AREA CHECK	
Total Proposed BuiltUp Area	179.34
ARCHITECT (Regd)	RANJIT KUMAR
ENGINEER (Regd)	
SUPERVISOR (Regd)	
OWNER (Regd)	LALITA DEVI
DEVELOPMENT AUTHORITY	LOCAL BODY

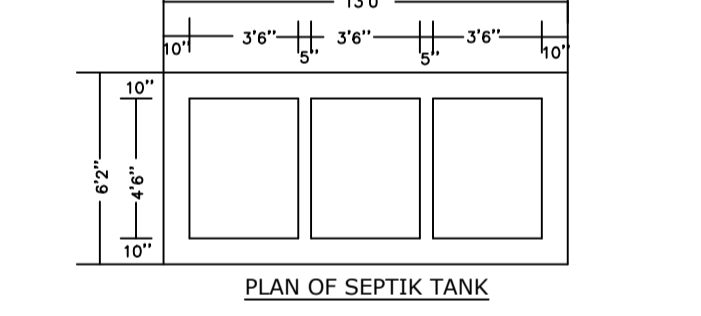
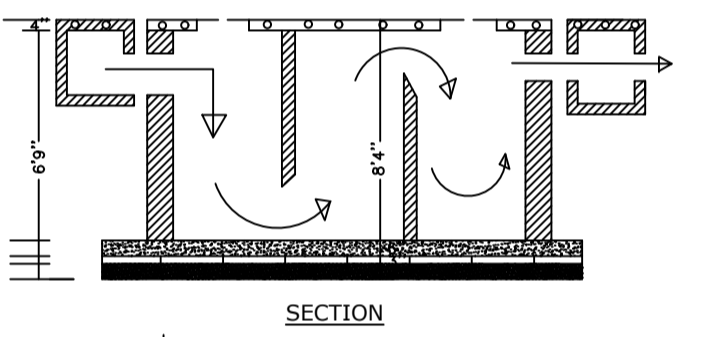
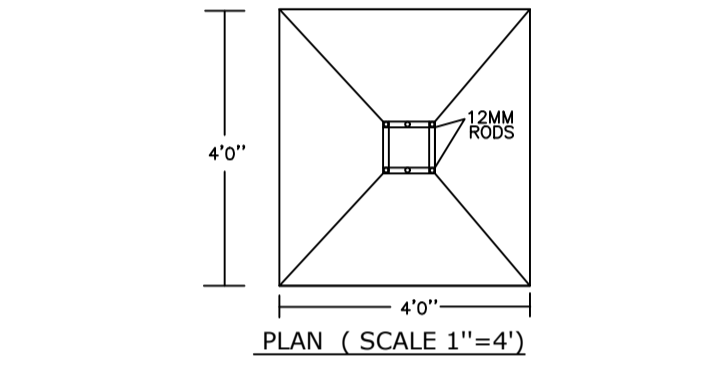
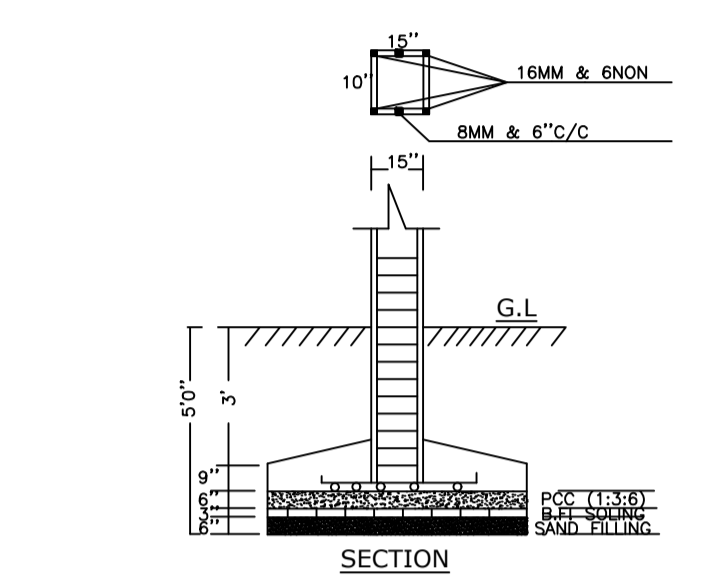

COLOR INDEX

PLOT BOUNDARY	Black
ABUTTING ROAD	Red
PROPOSED CONSTRUCTION	Green
COMMON PLOT	Yellow
ROAD WIDENING AREA	Blue
EXISTING (To be retained)	Light Blue
EXISTING (To be demolished)	Light Yellow

Buildingwise Floor FAR Details

Floor Name	Building Name A (RESIDENTIAL)		Total	
	Proposed Built Up Area (Sq.mt.)	Proposed FAR Area (Sq.mt.)	Total Proposed Built Up Area (Sq.mt.)	Total FAR Area (Sq.mt.)
Ground Floor	89.67	89.67	89.67	89.67
First Floor	89.67	89.67	89.67	89.67
Terrace Floor	0.00	0.00	0.00	0.00
Total :	179.34	179.34	179.34	179.34

Building USE/SUBUSE Details

Building Name	Building Use	Building SubUse	Building Structure
A (RESIDENTIAL)	Residential	Bungalow Dwelling / Non Apartment	Non-Highrise

Building : A (RESIDENTIAL)

Floor Name	Total Built Up Area (Sq.mt.)	Proposed FAR Area (Sq.mt.) Resi.	Total FAR Area (Sq.mt.)	Total Consumed Additional FAR Area (Sq.mt.)	Tnmt (No.)
Ground Floor	89.67	89.67	89.67	89.67	01
First Floor	89.67	89.67	89.67	89.67	00
Terrace Floor	0.00	0.00	0.00	0.00	00
Total :	179.34	179.34	179.34	179.34	01
Total Number of Same Buildings :	1				
Total :	179.34	179.34	179.34	179.34	01

SCHEDULE OF DOOR:

BUILDING NAME	NAME	LENGTH	HEIGHT	NOS
A (RESIDENTIAL)	D	0.90	2.10	10

SCHEDULE OF WINDOW/VENTILATION:

BUILDING NAME	NAME	LENGTH	HEIGHT	NOS
A (RESIDENTIAL)	V	0.90	0.60	02
A (RESIDENTIAL)	W	1.03	1.20	18

UnitBUA Table for Building :A (RESIDENTIAL)

FLOOR	Name	UnitBUA Type	UnitBUA Area	Carpet Area	No. of Rooms	No. of Tenement
GROUND FLOOR PLAN	SPLIT A	FLAT	159.12	158.04	6	1
FIRST FLOOR PLAN	SPLIT A	FLAT	0.00	0.00	6	0
Total:	-	-	159.12	158.04	12	1

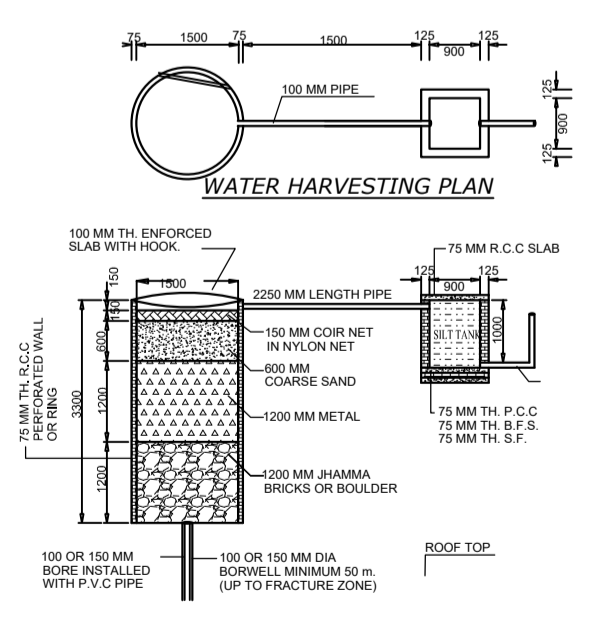

LTP NAME AND SIGNATURE	STRUCTURAL ENG'S NAME AND SIGNATURE	BUILDER NAME AND SIGNATURE	DIGITAL SIGNATURE
RANJIT KUMAR MNNP/ENG/0001/2016			