

Building :A (RESIDENTIAL)

| Floor Name | Total Built Up Area (Sq.mt.) | Proposed FAR Area (Sq.mt.) Resi. | Total FAR Area (Sq.mt.) | Total Consumed Additional FAR Area (Sq.mt.) | Tnmt (No.) |
|--------------------------------|------------------------------|----------------------------------|-------------------------|---|------------|
| Ground Floor | 75.60 | 75.60 | 75.60 | 75.60 | 01 |
| First Floor | 75.60 | 75.60 | 75.60 | 75.60 | 00 |
| Terrace Floor | 0.00 | 0.00 | 0.00 | 0.00 | 00 |
| Total : | 151.20 | 151.20 | 151.20 | 151.20 | 01 |
| Total Number of Same Buildings | 1 | | | | |
| Total : | 151.20 | 151.20 | 151.20 | 151.20 | 01 |

SCHEDULE OF DOOR:

| BUILDING NAME | NAME | LENGTH | HEIGHT | NOS |
|-----------------|------|--------|--------|-----|
| A (RESIDENTIAL) | D | 0.90 | 2.10 | 01 |
| A (RESIDENTIAL) | D | 0.95 | 2.10 | 01 |
| A (RESIDENTIAL) | D | 1.01 | 2.10 | 05 |
| A (RESIDENTIAL) | D | 1.07 | 2.10 | 01 |

SCHEDULE OF WINDOW/VENTILATION:

| BUILDING NAME | NAME | LENGTH | HEIGHT | NOS |
|-----------------|------|--------|--------|-----|
| A (RESIDENTIAL) | V | 0.91 | 0.90 | 01 |
| A (RESIDENTIAL) | W | 1.20 | 1.20 | 11 |

UnitBUA Table for Building :A (RESIDENTIAL)

| FLOOR | Name | UnitBUA Type | UnitBUA Area | Carpet Area | No. of Rooms | No. of Tenement |
|-------------------|---------|--------------|--------------|-------------|--------------|-----------------|
| GROUND FLOOR PLAN | SPLIT A | FLAT | 132.36 | 131.62 | 1 | 1 |
| FIRST FLOOR PLAN | SPLIT A | FLAT | 0.00 | 0.00 | 6 | 0 |
| Total: | - | - | 132.36 | 131.62 | 7 | 1 |

FAR & Tenement Details (Table 4c-1)

| Building | No. of Same Bldg | Total Built Up Area (Sq.mt.) | Proposed FAR Area (Sq.mt.) Resi. | Total FAR Area (Sq.mt.) | Total Consumed Additional FAR Area (Sq.mt.) | Tnmt (No.) |
|-----------------|------------------|------------------------------|----------------------------------|-------------------------|---|------------|
| A (RESIDENTIAL) | 1 | 151.20 | 151.20 | 151.20 | 151.20 | 01 |
| Grand Total : | 1 | 151.20 | 151.20 | 151.20 | 151.20 | 01 |

Proposal Basic Information

| | |
|-------------------|------------------------------------|
| Proposal File No. | MNNP/EP/0089/W07/2024 |
| Owner Name | SANTOSH KUMAR RAM |
| Khata No | 0 |
| Plot No | 1365,1366 |
| Village Name | Kundh |
| Use | Residential |
| SubUse | Bungalow/ Dwelling / Non Apartment |

AREA STATEMENT

| AREA DETAILS | SQ.MT. |
|---|-----------------------|
| AREA OF PLOT (Minimum) | (A) 118.61 |
| Deduction for NetPlot Area | |
| Surrender Free of Cost | 3.78 |
| NET AREA OF PLOT (Gross Plot Area - Deduction from Gross Plot area) | 114.83 |
| Deduction for Balance Plot Area (from Gross Plot Area) | |
| Surrender Free of Cost | 3.78 |
| Common Plot | 9.15 |
| Total | 12.93 |
| BALANCE AREA OF PLOT (Net Plot Area - Recreational/Amenity space) | (A-Deductions) 105.68 |
| PLOT AREA FOR COVERAGE (Net Plot Area) | (A-Deductions) 114.83 |
| Plot Area for FAR (Net Plot Area + Road Widening Area) | (A-Deductions) 118.61 |

COVERAGE CHECK

| | |
|---------------------------------------|-------|
| Permissible Coverage area (70.00 %) | 80.38 |
| Proposed Coverage Area (65.84 %) | 75.60 |
| Total Prop. Coverage Area (65.84 %) | 75.60 |
| Balance coverage area (4.16 %) | 4.78 |

FAR CHECK

| | |
|--------------------------|--------|
| Perm. FAR Area (1.800) | 213.50 |
| Total Perm. FAR area | 213.50 |
| Residential FAR | 151.21 |
| Proposed FAR Area | 151.21 |
| Total Proposed FAR Area | 151.21 |
| Consumed FAR (Factor) | 1.27 |
| Balance FAR Area | 62.29 |

BUILT UP AREA CHECK

| | |
|-----------------------------|--------|
| Total Proposed BuiltUp Area | 151.20 |
|-----------------------------|--------|

ARCHITECT (Regd) RANJIT KUMAR
ENGINEER (Regd)
SUPERVISOR (Regd)
OWNER (Regd) SANTOSH KUMAR RAM
DEVELOPMENT AUTHORITY LOCAL BODY

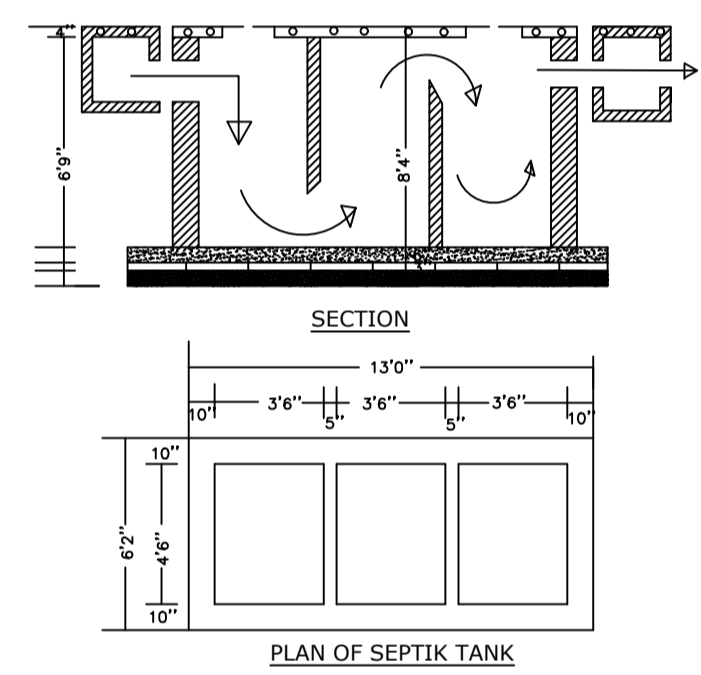
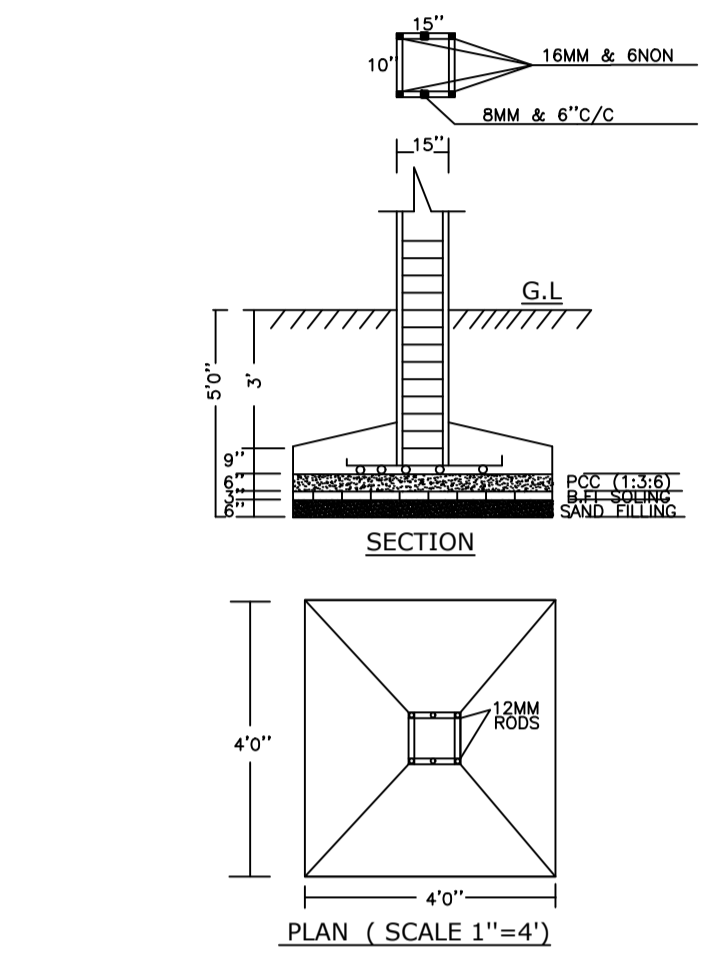

COLOR INDEX

| | |
|-----------------------------|--------|
| PLOT BOUNDARY | Black |
| ABUTTING ROAD | Green |
| PROPOSED CONSTRUCTION | Red |
| COMMON PLOT | Yellow |
| ROAD WIDENING AREA | Blue |
| EXISTING (To be retained) | Orange |
| EXISTING (To be demolished) | White |

Buildingwise Floor FAR Details

| Floor Name | Building Name A (RESIDENTIAL) | | Total | |
|---------------|---------------------------------|----------------------------|---------------------------------------|-------------------------|
| | Proposed Built Up Area (Sq.mt.) | Proposed FAR Area (Sq.mt.) | Total Proposed Built Up Area (Sq.mt.) | Total FAR Area (Sq.mt.) |
| Ground Floor | 75.60 | 75.60 | 75.60 | 75.60 |
| First Floor | 75.60 | 75.60 | 75.60 | 75.60 |
| Terrace Floor | 0.00 | 0.00 | 0.00 | 0.00 |
| Total : | 151.20 | 151.20 | 151.20 | 151.20 |

Building USE/SUBUSE Details

| Building Name | Building Use | Building SubUse | Building Structure |
|-----------------|--------------|------------------------------------|--------------------|
| A (RESIDENTIAL) | Residential | Bungalow/ Dwelling / Non Apartment | Non-Highrise |

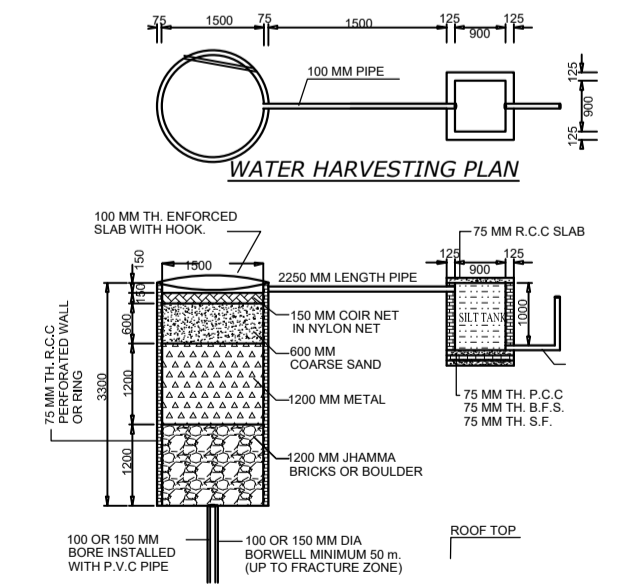

| LTP NAME AND SIGNATURE | STRUCTURAL ENG'S NAME AND SIGNATURE | BUILDER NAME AND SIGNATURE | DIGITAL SIGNATURE |
|------------------------------------|-------------------------------------|----------------------------|-------------------|
| RANJIT KUMAR MNNP/ENG/0001/2016 | | | |