

Proposal Basic Information	
Proposal File No.	MNNP/BI/0138/W02/2024
Owner Name	RAJENDRA PRASAD AGARWAL
Khata No	40
Plot No	86
Village Name	Sudna
Use	Mixed
SubUse	Resi+Comm

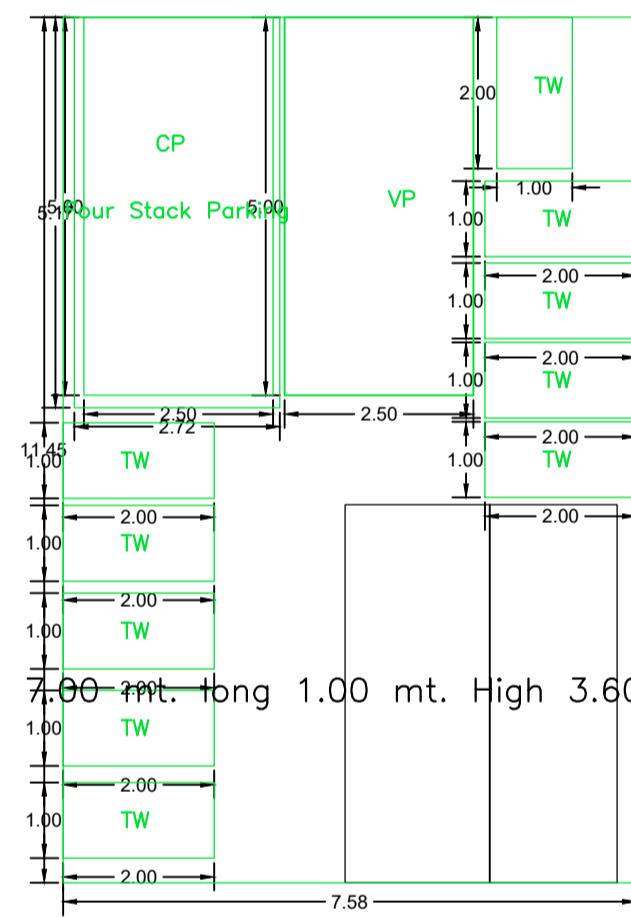

BASEMENT FLOOR PLAN (SCALE 1:100)

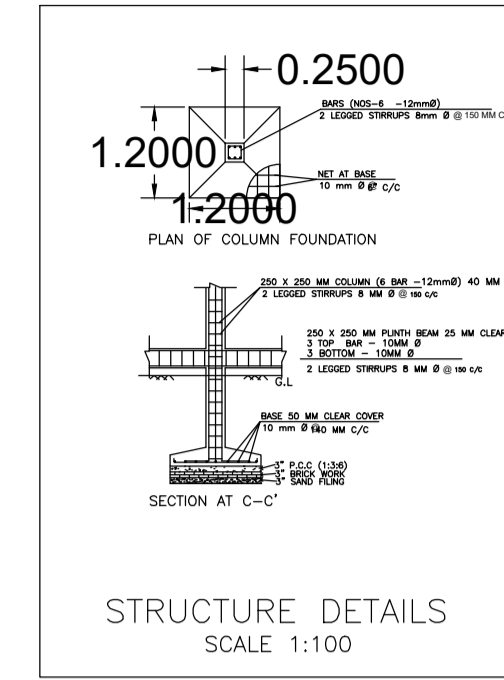
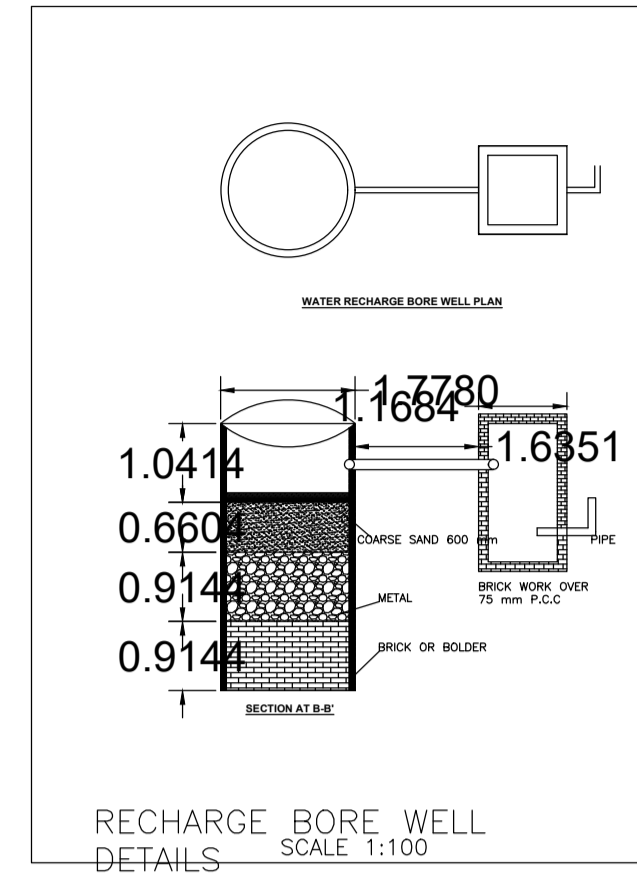
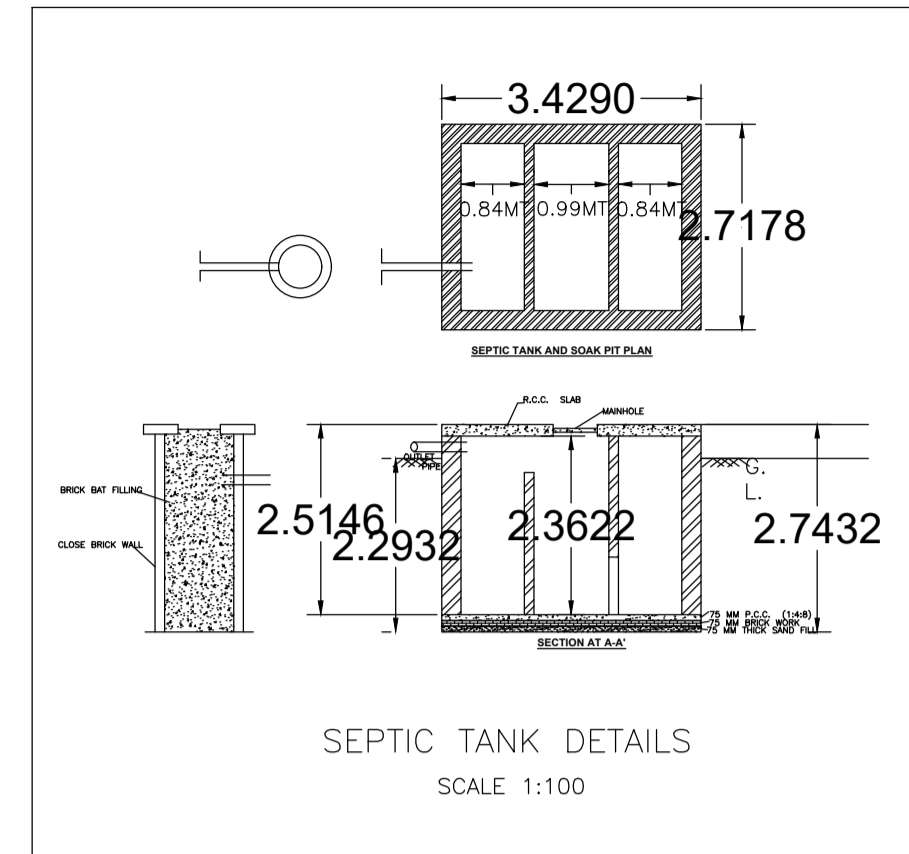
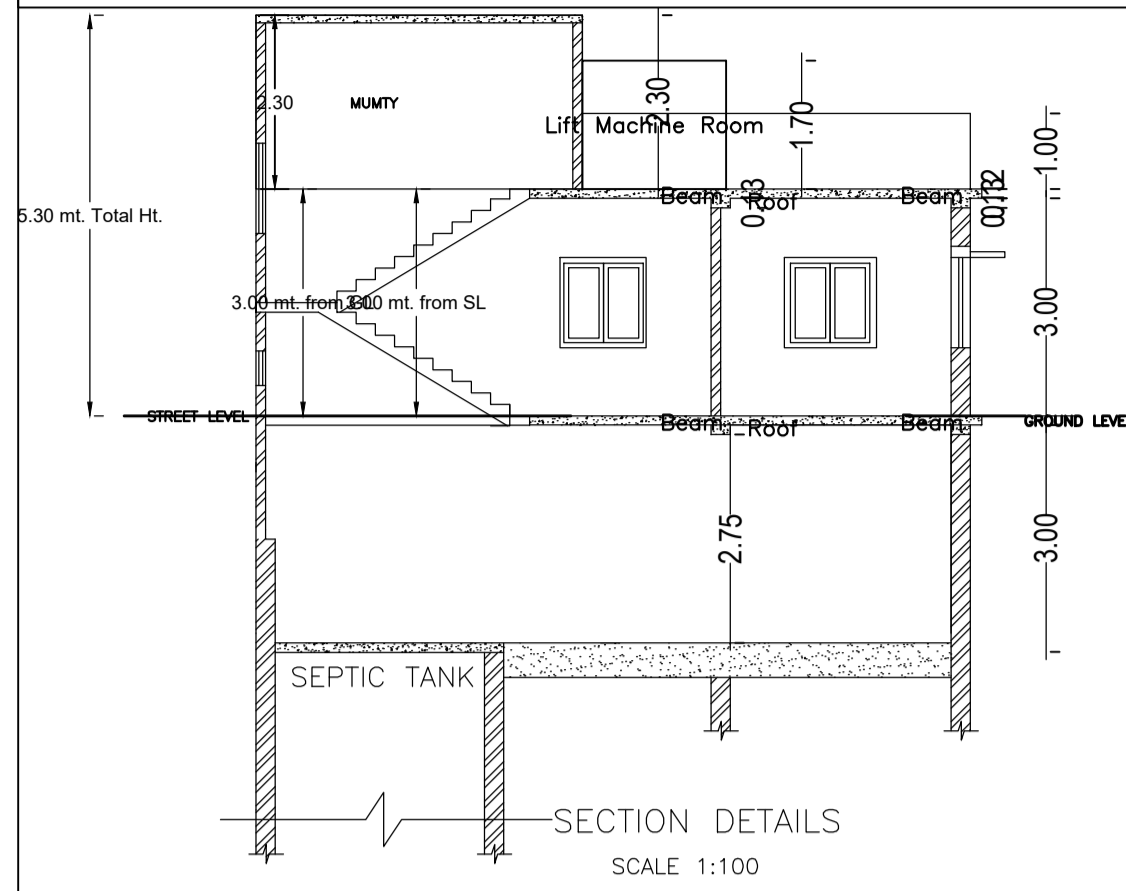
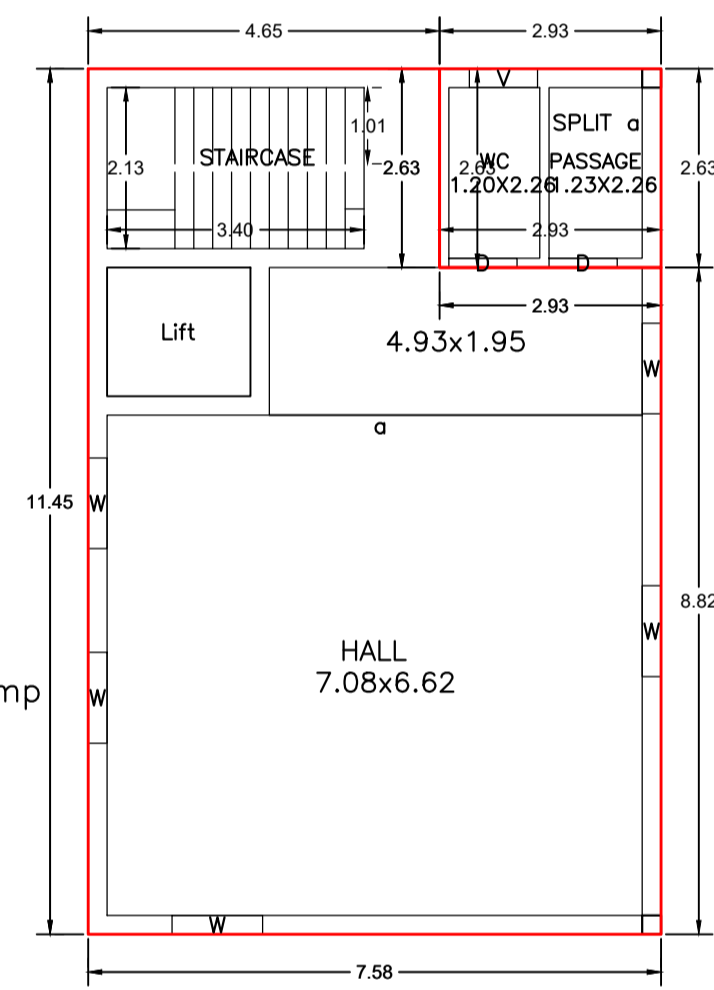

GROUND FLOOR PLAN (Proposed) (SCALE 1:100)

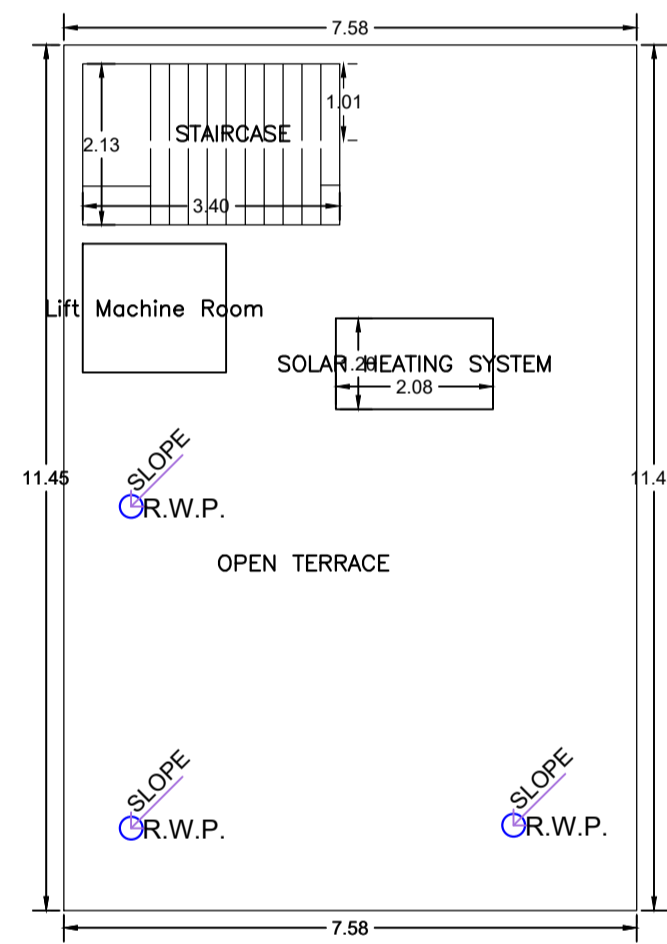

TERRACE FLOOR PLAN (SCALE 1:100)

Building :A (BUILDING)

Floor Name	Total Built Up Area (Sq.mt.)	Deductions (Area in Sq.mt.)			Proposed FAR Area (Sq.mt.)	Total FAR Area (Sq.mt.)	Total Consumed Additional FAR Area (Sq.mt.)	Tmnt (No.)
		Parking	Resi.	Commercial				
Basement Floor	86.77	68.77	0.00	0.00	0.00	0.00	00	
Ground Floor	86.77	0.00	7.71	79.06	86.77	86.77	02	
Terrace Floor	0.00	0.00	0.00	0.00	0.00	0.00	00	
Total :	173.54	68.77	7.71	79.06	86.77	86.77	02	
Total Number of Same Buildings	1							
Total :	173.54	68.77	7.71	79.06	86.77	86.77	02	

SCHEDULE OF DOOR:

BUILDING NAME	NAME	LENGTH	HEIGHT	NOS
A (BUILDING)	D	0.90	2.10	02

SCHEDULE OF WINDOW/VENTILATION:

BUILDING NAME	NAME	LENGTH	HEIGHT	NOS
A (BUILDING)	V	0.90	0.60	01
A (BUILDING)	W	1.20	1.20	05

UnitBUA Table for Building :A (BUILDING)

FLOOR	Name	UnitBUA Type	UnitBUA Area	Carpert Area	No. of Rooms	No. of Tenement
GROUND FLOOR PLAN	a	SHOP	62.15	62.09	1	2
	SPLIT a	FLAT	7.71	7.64	2	2
Total:	-	-	69.86	69.73	3	2

LTP NAME AND SIGNATURE	STRUCTURAL ENG'S NAME AND SIGNATURE	BUILDER NAME AND SIGNATURE	DIGITAL SIGNATURE
SHAIENDRA KUMAR VERMA MNNP/ENG/0007/2021			