

Proposal Basic Information	
Proposal File No.	MNNP/BP/0233/W01/2024
Owner Name	Deepak Kumar Agarwal and Ankita Agrawal
Khata No	00
Plot No	213
Village Name	Kundh
Use	Residential
SubUse	Bungalow/ Dwelling / Non Apartment

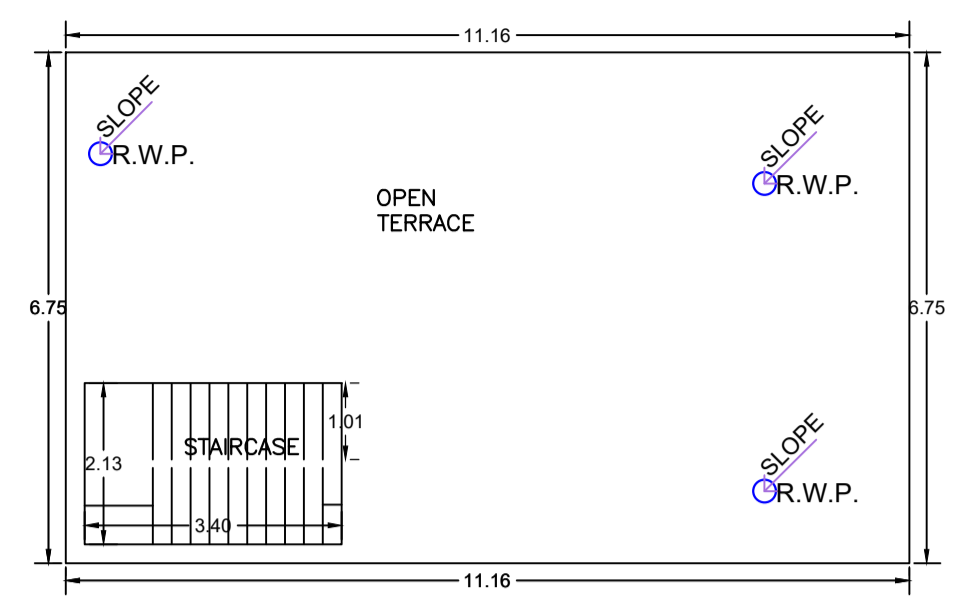

SITE PLAN

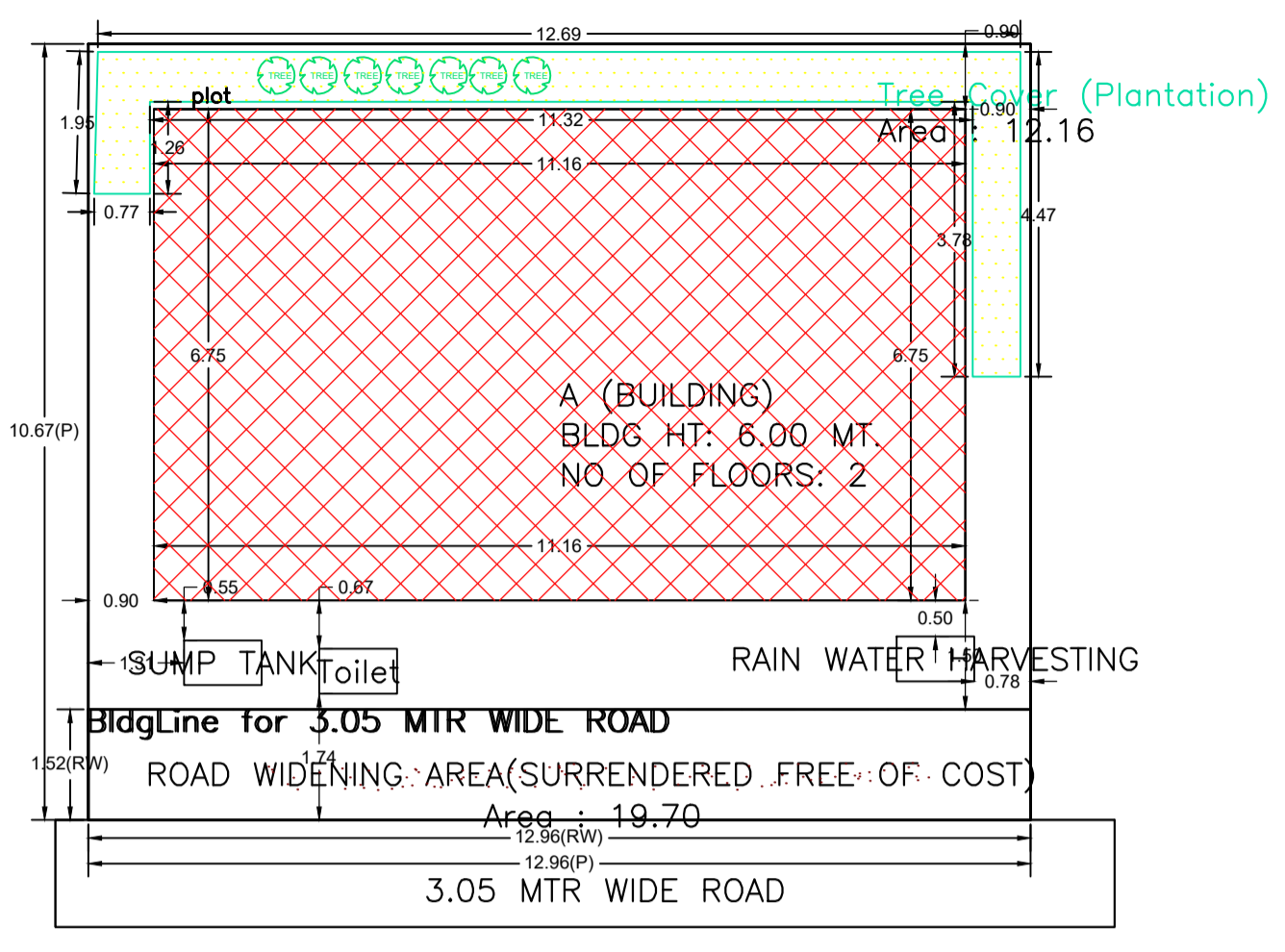
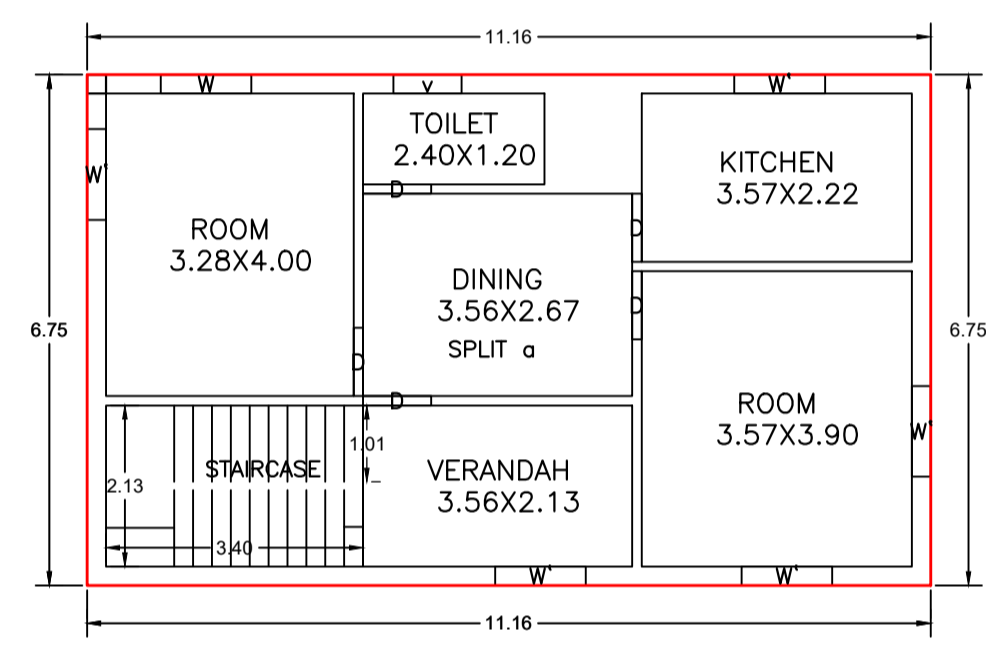
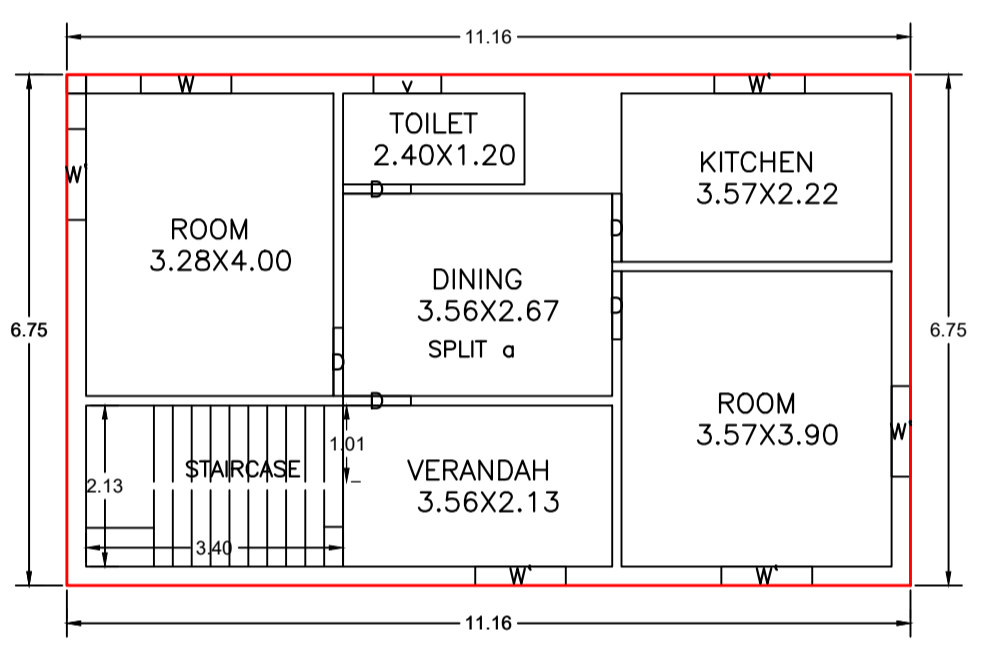

GROUND FLOOR PLAN (Proposed) (SCALE 1:100)

FIRST FLOOR PLAN (Proposed) (SCALE 1:100)

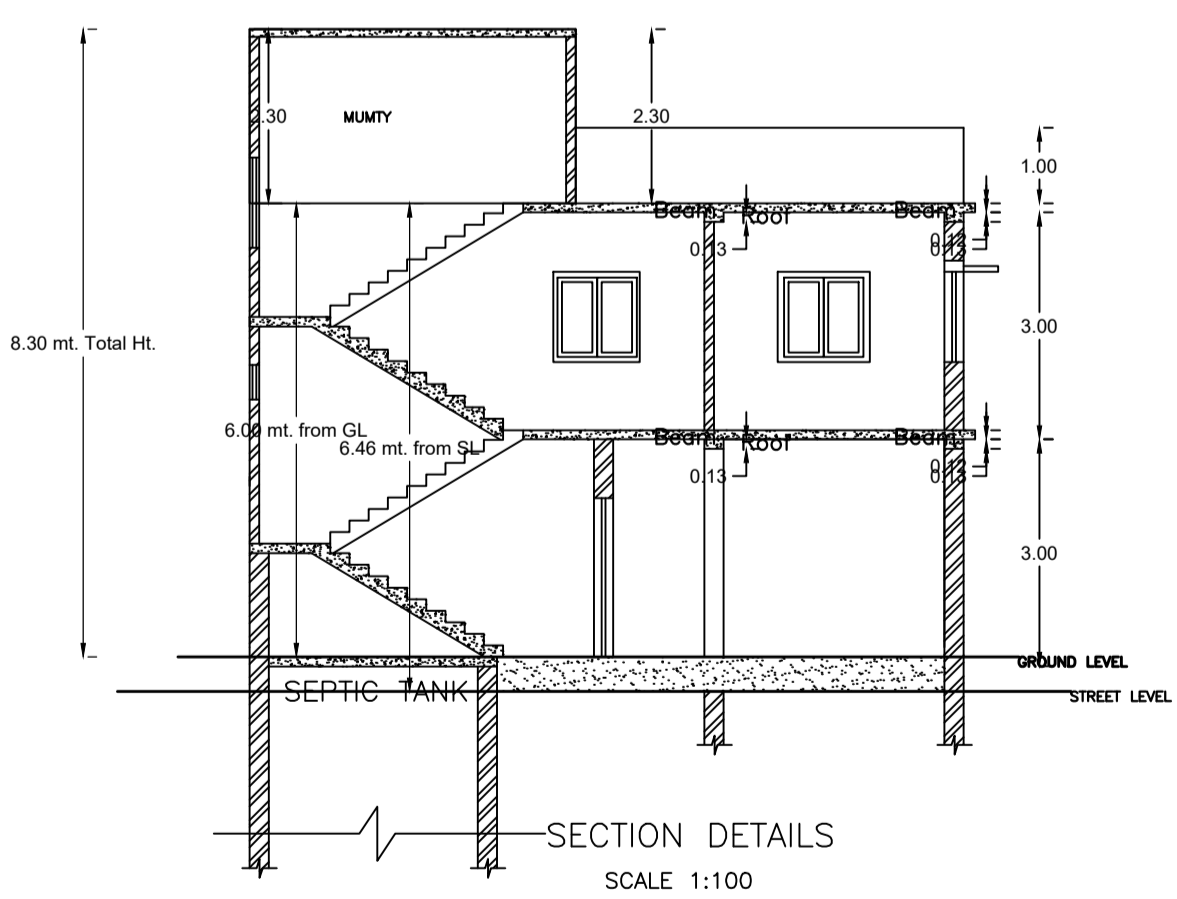

SECTION DETAILS (SCALE 1:100)

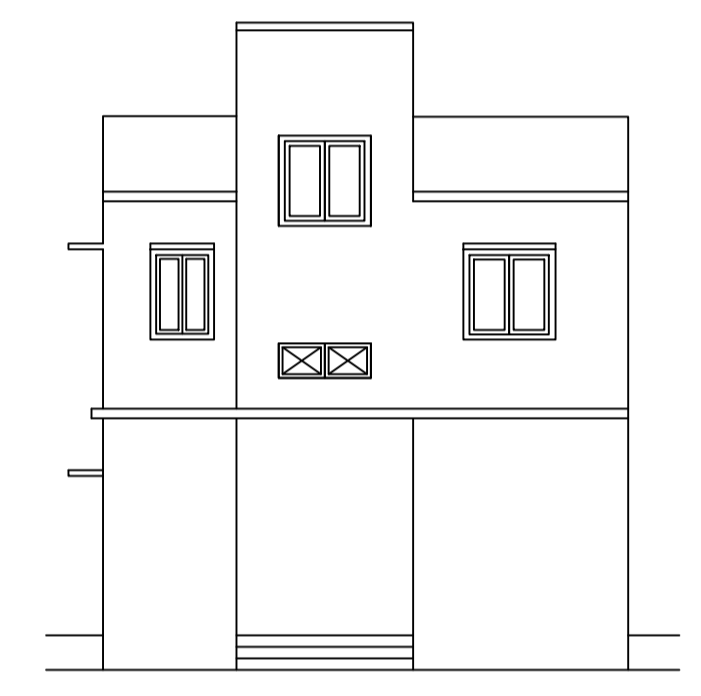

FRONT ELEVATION (SCALE 1:100)

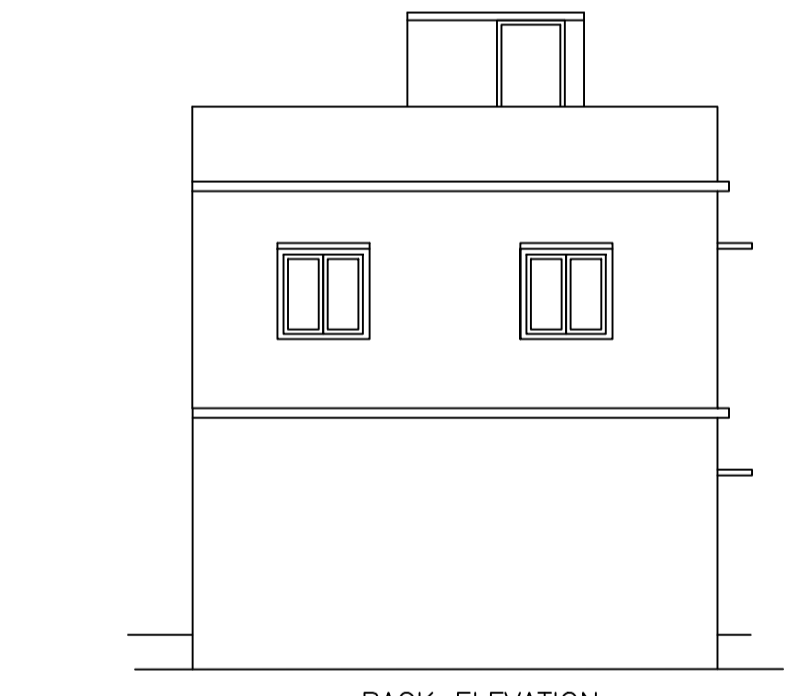

BACK ELEVATION (SCALE 1:100)

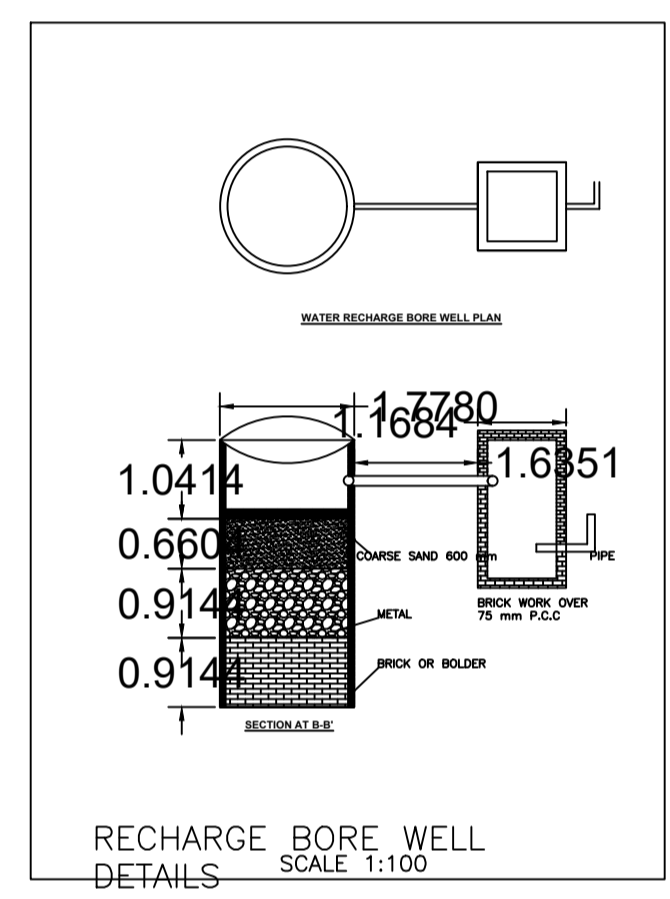

RECHARGE BORE WELL DETAILS (SCALE 1:100)

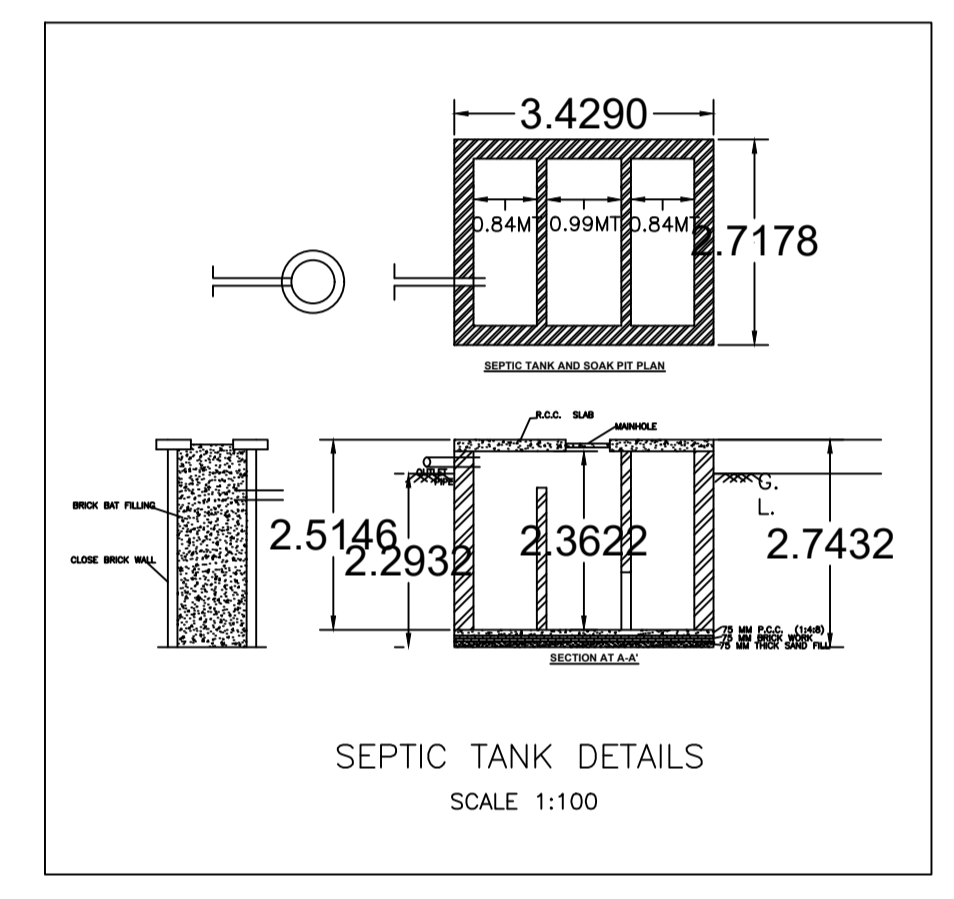

SEPTIC TANK DETAILS (SCALE 1:100)

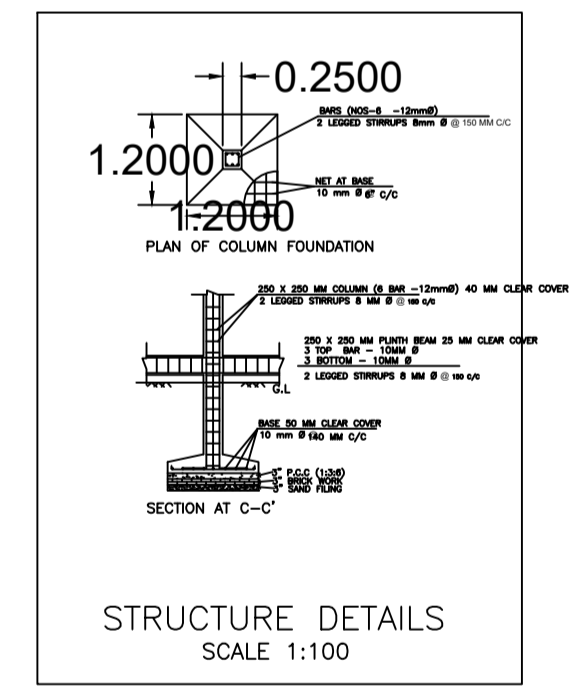

STRUCTURE DETAILS (SCALE 1:100)

Building USE/SUBUSE Details

Building Name	Building Use	Building SubUse	Building Structure	Floor Name	Floor Use	Floor SubUse	FAR Name	FAR Use	FAR SubUse
A (BUILDING)	Residential	Bungalow/ Dwelling / Non Apartment	Non-Highrise	GROUND FLOOR PLAN	Residential	Bungalow/ Dwelling / Non Apartment	Residential FAR	Residential	Bungalow/ Dwelling / Non Apartment
				FIRST FLOOR PLAN	Residential	Bungalow/ Dwelling / Non Apartment	Residential FAR	Residential	Bungalow/ Dwelling / Non Apartment
				TERRACE FLOOR PLAN	Residential	Bungalow/ Dwelling / Non Apartment	-	-	-

AREA STATEMENT		VERSION NO.: 1.0.73
MEDININAGAR MUNICIPAL CORPORATION		VERSION DATE: 16/10/2020
PROJECT DETAIL:		
Region: JHARKHAND URBAN LOCAL BODIES	Plot Use: Residential	
District: PALAMU	Plot SubUse: Bungalow/ Dwelling / Non Apartment	
Authority: MEDININAGAR MUNICIPAL CORPORATION	Plot/Nearby/Religious Structure: NA	
Inward No: MNNP/BP/0233/W01/2024	Plot/SubPlot No: 213	
Application Type: General Proposal	North: -	
Project Type: Building Permission	South: -	
Nature of Development: New	East: -	
Location of Development Area: New	West: -	
Area		SQ.MT.
AREA OF PLOT (Minimum)	(A)	138.34
Deduction for NetPlot Area		
Surrender Free of Cost		19.70
Total		19.70
NET AREA OF PLOT (Gross Plot Area - Deduction from Gross Plot area)	(A-Deductions)	118.64
Deduction for Balance Plot Area (from Gross Plot Area)		
Surrender Free of Cost		19.70
Common Plot		12.16
Total		31.86
BALANCE AREA OF PLOT (Net Plot Area - Recreational/Amenity space)	(A-Deductions)	106.48
PLOT AREA FOR COVERAGE (Net Plot Area)	(A-Deductions)	118.64
Plot Area for FAR (Net Plot Area + Road Widening Area)	(A-Deductions)	138.34
COVERAGE CHECK		
Permissible Coverage area (70.00 %)		83.05
Proposed Coverage Area (63.54 %)		75.38
Total Prop. Coverage Area (63.54 %)		75.38
Balance coverage area (6.47 %)		7.67
FAR CHECK		
Perm. FAR Area (1.200)		166.01
Total Perm. FAR area		166.01
Residential FAR		150.75
Proposed FAR Area		150.75
Total Proposed FAR Area		150.75
Consumed FAR (Factor)		1.09
Balance FAR Area		15.26
BUILT UP AREA CHECK		
Total Proposed BuiltUp Area		150.76
ARCHITECT (Regd)	DILIP KUMAR SINGH	
ENGINEER (Regd)		
SUPERVISOR (Regd)		
OWNER (Regd)	Deepak Kumar Agarwal and Ankita Agrawal	
DEVELOPMENT AUTHORITY		LOCAL BODY

COLOR INDEX	
PLOT BOUNDARY	Black
ABUTTING ROAD	Green
PROPOSED CONSTRUCTION	Red
COMMON PLOT	Yellow
ROAD WIDENING AREA	Blue
EXISTING (To be retained)	Light Blue
EXISTING (To be demolished)	Light Yellow

Buildingwise Floor FAR Details

Floor Name	Building Name		Total	
	Proposed Built Up Area (Sq.mt.)	Proposed FAR Area (Sq.mt.)	Total Proposed Built Up Area (Sq.mt.)	Total FAR Area (Sq.mt.)
Ground Floor	75.38	75.38	75.38	75.38
First Floor	75.38	75.38	75.38	75.38
Terrace Floor	0.00	0.00	0.00	0.00
Total :	150.76	150.76	150.76	150.76

FAR & Tenement Details (Table 4c-1)

Building	No. of Same Bldg	Total Built Up Area (Sq.mt.)	Proposed FAR Area (Sq.mt.)	Total FAR Area (Sq.mt.)	Total Consumed Additional FAR Area (Sq.mt.)	Tnmt (No.)
A (BUILDING)	1	150.76	150.76	150.76	150.76	01
Grand Total :	1	150.76	150.76	150.76	150.76	01

Building :A (BUILDING)

Floor Name	Total Built Up Area (Sq.mt.)	Proposed FAR Area (Sq.mt.)	Total FAR Area (Sq.mt.)	Total Consumed Additional FAR Area (Sq.mt.)	Tnmt (No.)
Ground Floor	75.38	75.38	75.38	75.38	01
First Floor	75.38	75.38	75.38	75.38	00
Terrace Floor	0.00	0.00	0.00	0.00	00
Total :	150.76	150.76	150.76	150.76	01
Total Number of Same Buildings :	1				
Total :	150.76	150.76	150.76	150.76	01

SCHEDULE OF DOOR:

BUILDING NAME	NAME	LENGTH	HEIGHT	NOS
A (BUILDING)	D	0.90	2.10	10

SCHEDULE OF WINDOW/VENTILATION:

BUILDING NAME	NAME	LENGTH	HEIGHT	NOS
A (BUILDING)	v	0.90	0.60	02
A (BUILDING)	w	1.20	1.20	02
A (BUILDING)	w'	1.20	1.20	10

UnitBUA Table for Building :A (BUILDING)

FLOOR	Name	UnitBUA Type	UnitBUA Area	Carpet Area	No. of Rooms	No. of Tenement
GROUND FLOOR PLAN	SPLIT a	FLAT	133.38	133.26	6	1
FIRST FLOOR PLAN	SPLIT a	FLAT	0.00	0.00	6	0
Total:	-	-	133.38	133.26	12	1

LTP NAME AND SIGNATURE	STRUCTURAL ENG'S NAME AND SIGNATURE	BUILDER NAME AND SIGNATURE	DIGITAL SIGNATURE
DILIP KUMAR SINGH MNNP/ENG/0001/2024			