

Proposal Basic Information

Proposal File No.	MNNP/BP/0220/W02/2024
Owner Name	MEERA DEVI
Khata No	14
Plot No	33
Village Name	Nimiya
Use	Residential
SubUse	Bungalow/ Dwelling / Non Apartment

AREA STATEMENT	VERSION NO. : 1.0.72
MEDINAGAR MUNICIPAL CORPORATION	VERSION DATE: 16/10/2020

PROJECT DETAIL:

Region : JHARKHAND URBAN LOCAL BODIES	Plot Use: Residential
District: PALAMU	Plot SubUse: Bungalow/ Dwelling / Non Apartment
Authority: MEDINAGAR MUNICIPAL CORPORATION	Plot/Nearby/Religious/Structure: NA
Inward No: MNNP/BP/0220/W02/2024	Plot/SubPlot No: 33
Application Type: General Proposal	North: -
Project Type: Building Permission	South: -
Nature of Development: New	East: -
Location of Development Area: New	West: -

AREA DETAILS:

AREA OF PLOT (Minimum)	(A)	SQ.MT.	101.20
Deduction for NetPlot Area			10.97
Surrender Free of Cost			10.97
Total			10.97
NET AREA OF PLOT(Gross Plot Area - Deduction from Gross Plot area)	(A-Deductions)		90.23
Deduction for Balance Plot Area(from Gross Plot Area)			10.97
Surrender Free of Cost			10.74
Total			21.71
BALANCE AREA OF PLOT(Net Plot Area - Recreational/Amenity space)	(A-Deductions)		79.49
PLOT AREA FOR COVERAGE(Net Plot Area)	(A-Deductions)		90.23
Plot Area for FAR (Net Plot Area + Road/Widening Area)	(A-Deductions)		101.20

COVERAGE CHECK

Permissible Coverage area ( 70.00 % )	63.16
Proposed Coverage Area ( 63.05 % )	56.89
Total Prop. Coverage Area ( 63.05 % )	56.89
Balance coverage area ( 6.95 % )	6.27

FAR CHECK

Perm. FAR Area ( 1.200 )	121.44
Total Perm. FAR area	121.44
Residential FAR	113.78
Proposed FAR Area	113.78
Total Proposed FAR Area	113.78
Consumed FAR (Factor)	1.12
Balance FAR Area	7.66

BUILT UP AREA CHECK

Total Proposed BuiltUp Area	113.78
-----------------------------	--------

ARCHITECT (Regd) Umesh Prasad  
ENGINEER (Regd)  
SUPERVISOR (Regd)  
OWNER (Regd) MEERA DEVI  
DEVELOPMENT AUTHORITY LOCAL BODY

COLOR INDEX

PLOT BOUNDARY	Black
ABUTTING ROAD	Red
PROPOSED CONSTRUCTION	Green
COMMON PLOT	Yellow
ROAD WIDENING AREA	Blue
EXISTING (To be retained)	Orange
EXISTING (To be demolished)	Pink

Buildingwise Floor FAR Details

Floor Name	Building Name A (RESIDENTIAL)		Total	
	Proposed Built Up Area (Sq.mt.)	Proposed FAR Area (Sq.mt.)	Total Proposed Built Up Area (Sq.mt.)	Total FAR Area (Sq.mt.)
Ground Floor	56.89	56.89	56.89	56.89
First Floor	56.89	56.89	56.89	56.89
Terrace Floor	0.00	0.00	0.00	0.00
Total :	113.78	113.78	113.78	113.78

FAR & Tenement Details (Table 4c-1)

Building	No. of Same Bldg	Total Built Up Area (Sq.mt.)	Proposed FAR Area (Sq.mt.)	Total FAR Area (Sq.mt.)	Total Consumed Additional FAR Area (Sq.mt.)	Tnmt (No.)
A (RESIDENTIAL)	1	113.78	113.78	113.78	113.78	01
Grand Total :	1	113.78	113.78	113.78	113.78	01

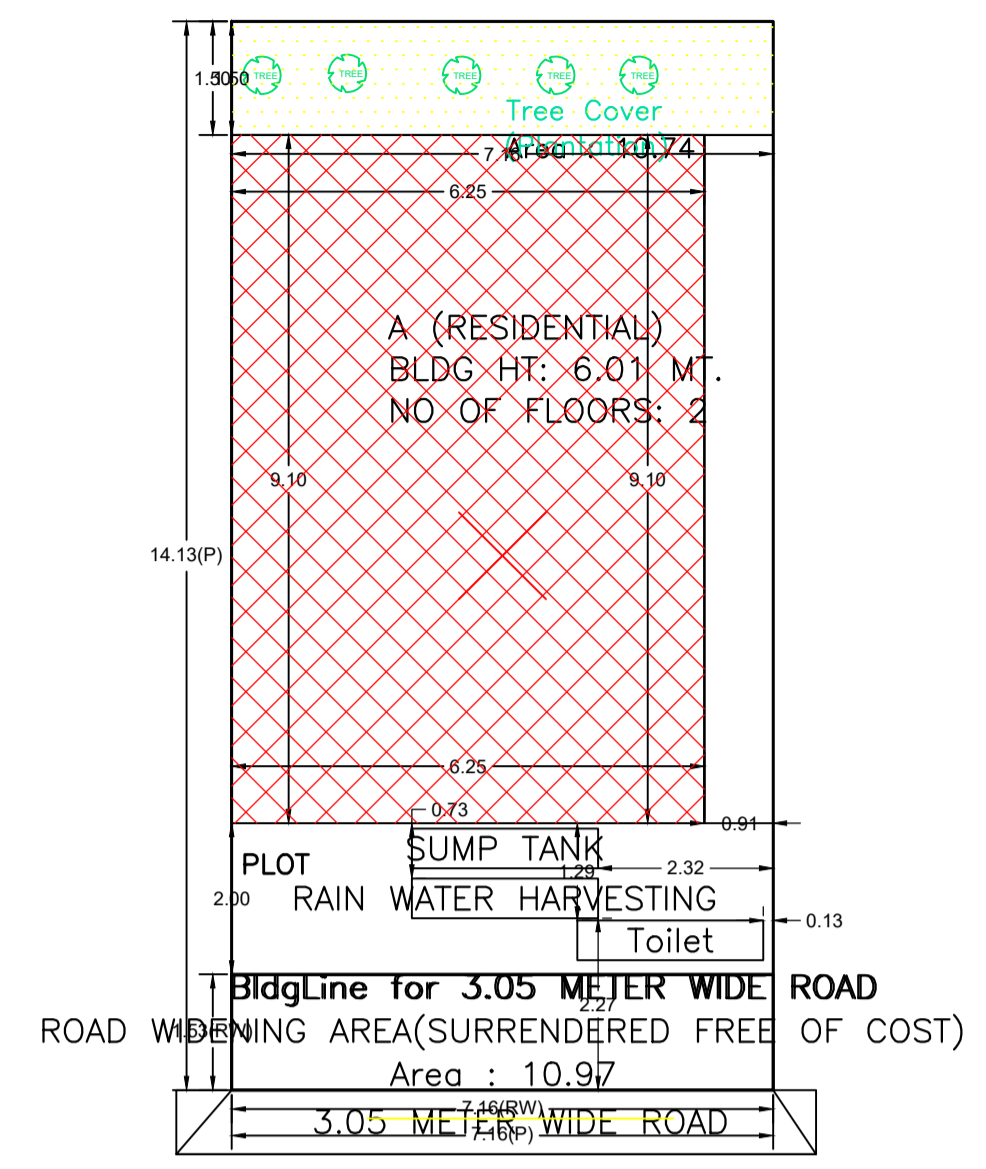

SITE PLAN

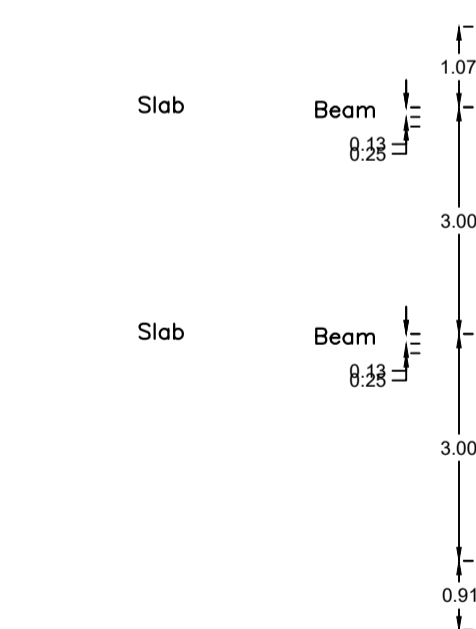
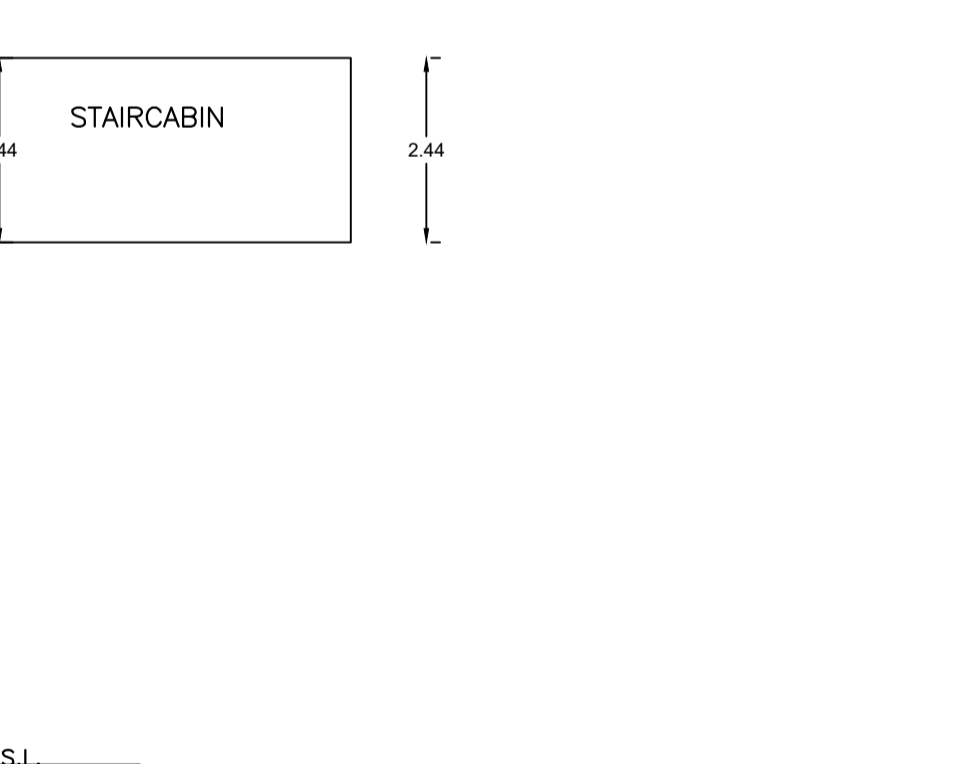
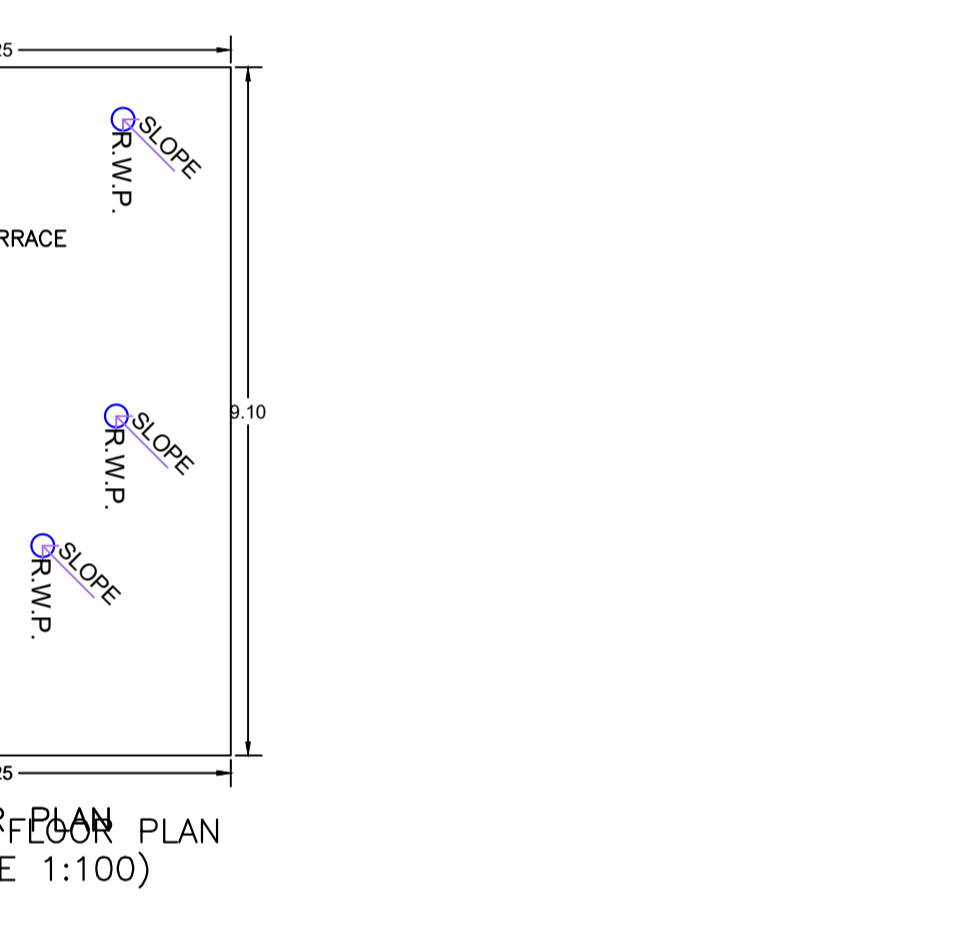
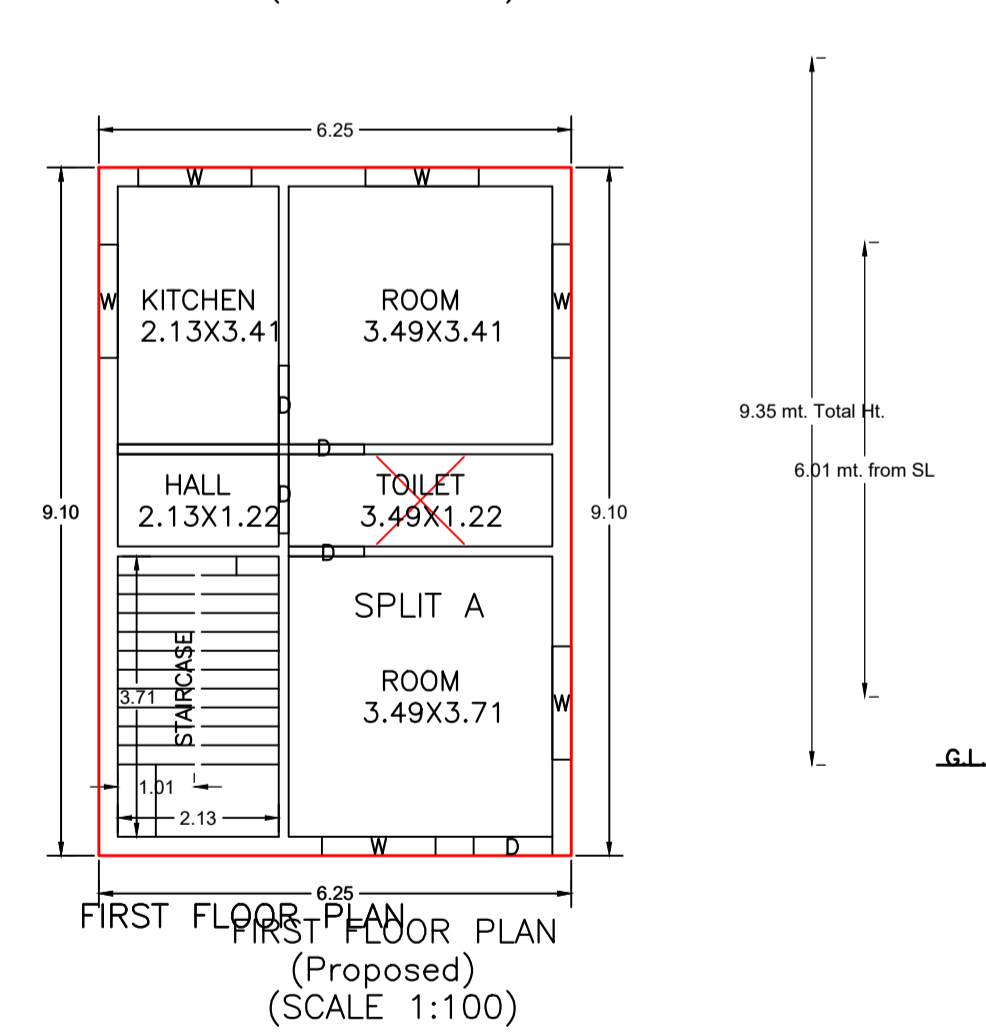
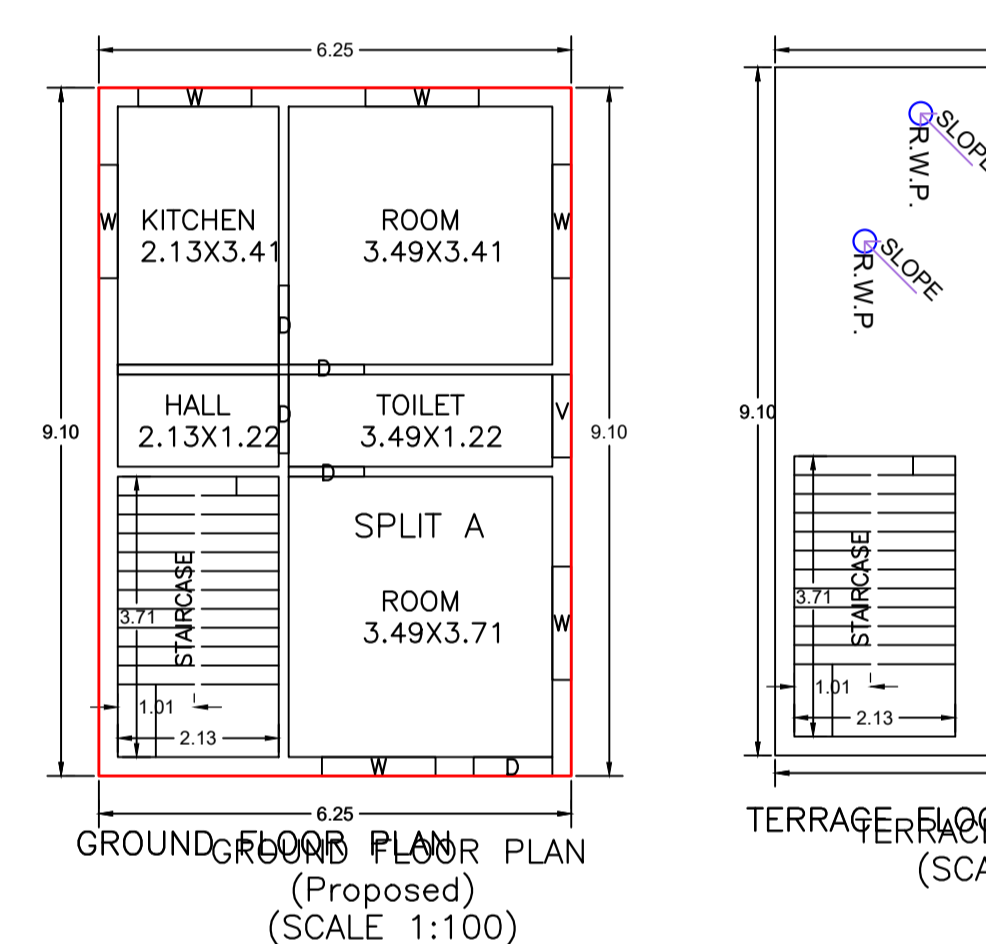

Building USE/SUBUSE Details

Building Name	Building Use	Building SubUse	Building Structure	Floor Name	Floor Use	Floor SubUse	FAR Name	FAR Use	FAR SubUse
A (RESIDENTIAL)	Residential	Bungalow/ Dwelling / Non Apartment	Non-Highrise	GROUND FLOOR PLAN	Residential	Bungalow/ Dwelling / Non Apartment	Residential FAR	Residential	Bungalow/ Dwelling / Non Apartment
				TERRACE FLOOR PLAN	Residential	Bungalow/ Dwelling / Non Apartment	-	-	-
				FIRST FLOOR PLAN	Residential	Bungalow/ Dwelling / Non Apartment	Residential FAR	Residential	Bungalow/ Dwelling / Non Apartment

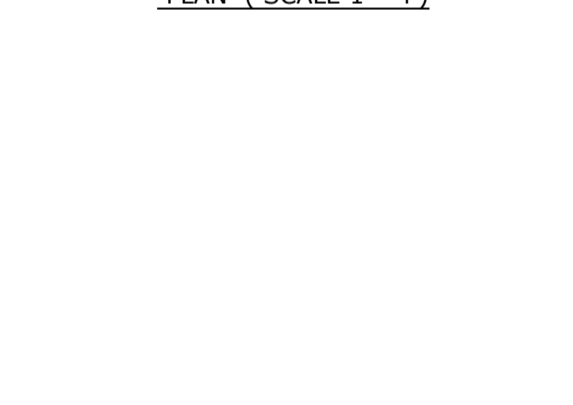
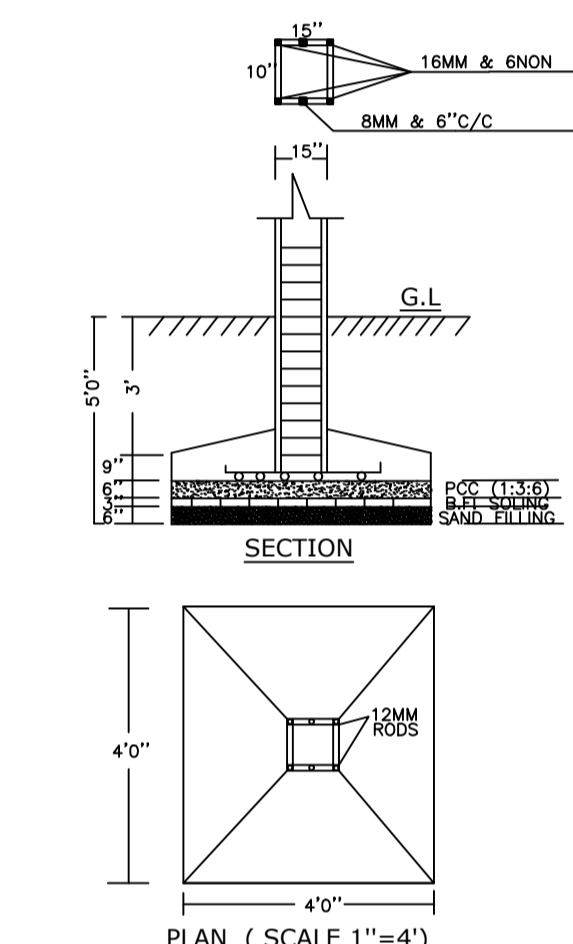
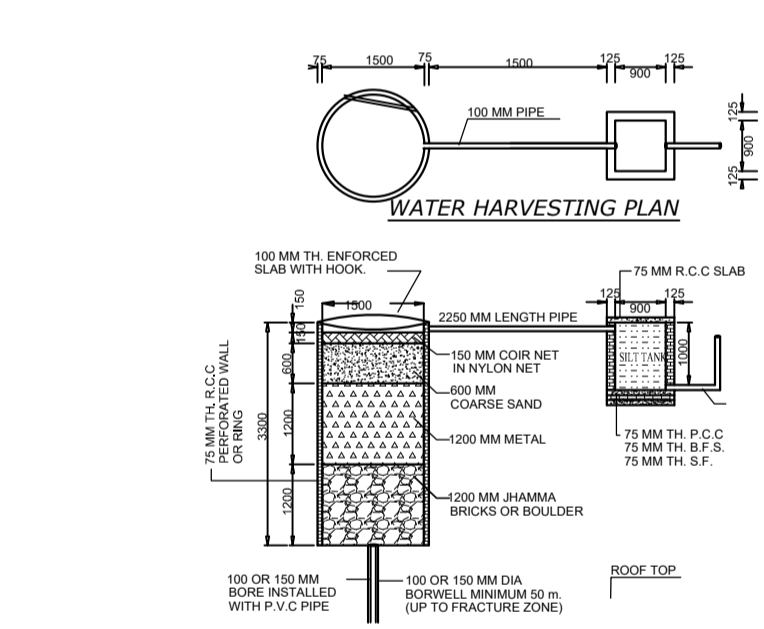
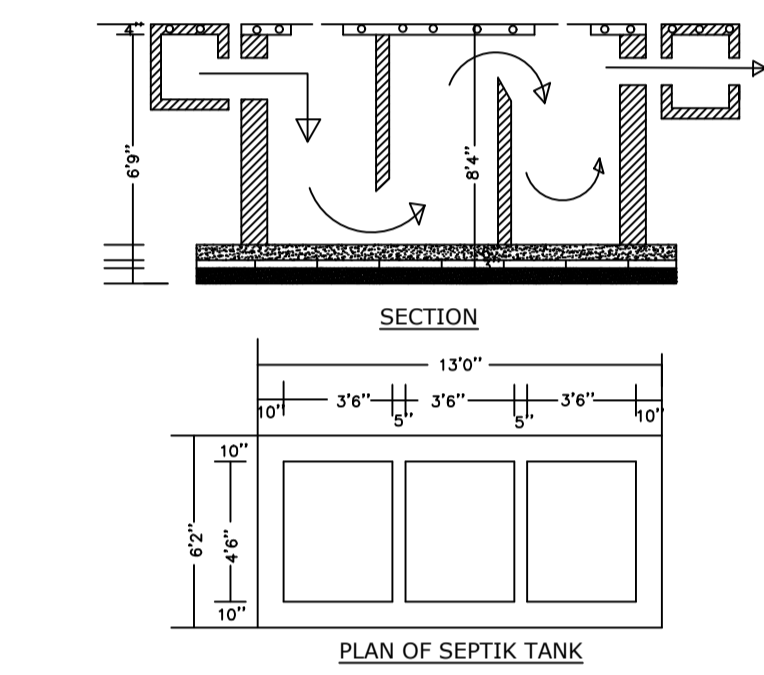

Building :A (RESIDENTIAL)

Floor Name	Total Built Up Area (Sq.mt.)	Proposed FAR Area (Sq.mt.) Resi.	Total FAR Area (Sq.mt.)	Total Consumed Additional FAR Area (Sq.mt.)	Tnmt (No.)
Ground Floor	56.89	56.89	56.89	56.89	01
First Floor	56.89	56.89	56.89	56.89	00
Terrace Floor	0.00	0.00	0.00	0.00	00
Total :	113.78	113.78	113.78	113.78	01
Total Number of Same Buildings :	1				
Total :	113.78	113.78	113.78	113.78	01

SCHEDULE OF DOOR:

BUILDING NAME	NAME	LENGTH	HEIGHT	NOS
A (RESIDENTIAL)	D	1.00	2.10	04
A (RESIDENTIAL)	D	1.04	2.10	06

SCHEDULE OF WINDOW/VENTILATION:

BUILDING NAME	NAME	LENGTH	HEIGHT	NOS
A (RESIDENTIAL)	V	1.10	1.20	01
A (RESIDENTIAL)	W	1.50	1.20	12

UnitBUA Table for Building :A (RESIDENTIAL)

FLOOR	Name	UnitBUA Type	UnitBUA Area	Carpet Area	No. of Rooms	No. of Tenement
GROUND FLOOR PLAN	SPLIT A	FLAT	94.93	94.37	5	1
FIRST FLOOR PLAN	SPLIT A	FLAT	0.00	0.00	5	0
Total:	-	-	94.93	94.37	10	1

LTP NAME AND SIGNATURE	STRUCTURAL ENG'S NAME AND SIGNATURE	BUILDER NAME AND SIGNATURE	DIGITAL SIGNATURE
Umesh Prasad MNNP/ENG/0002/2024			