

Proposal Basic Information

Proposal File No.	MNNP/BI/0232/W02/2024
Owner Name	ANITA DEVI
Khata No	44
Plot No	231/235
Village Name	Nimiya
Use	Residential
SubUse	Bungalow/ Dwelling / Non Apartment

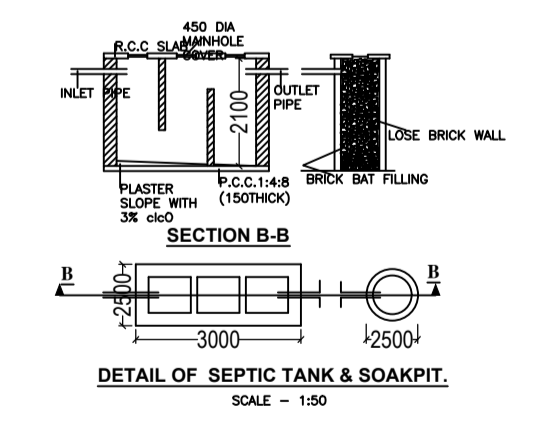
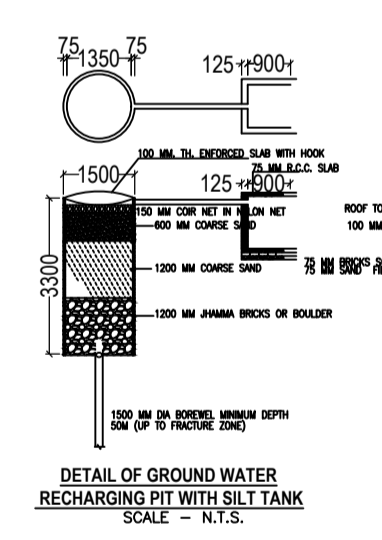
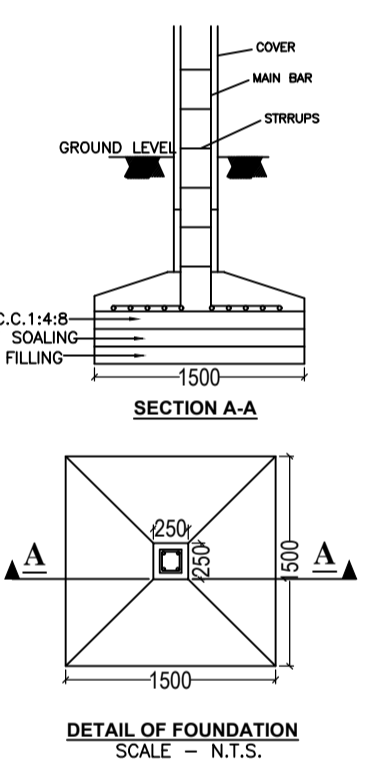
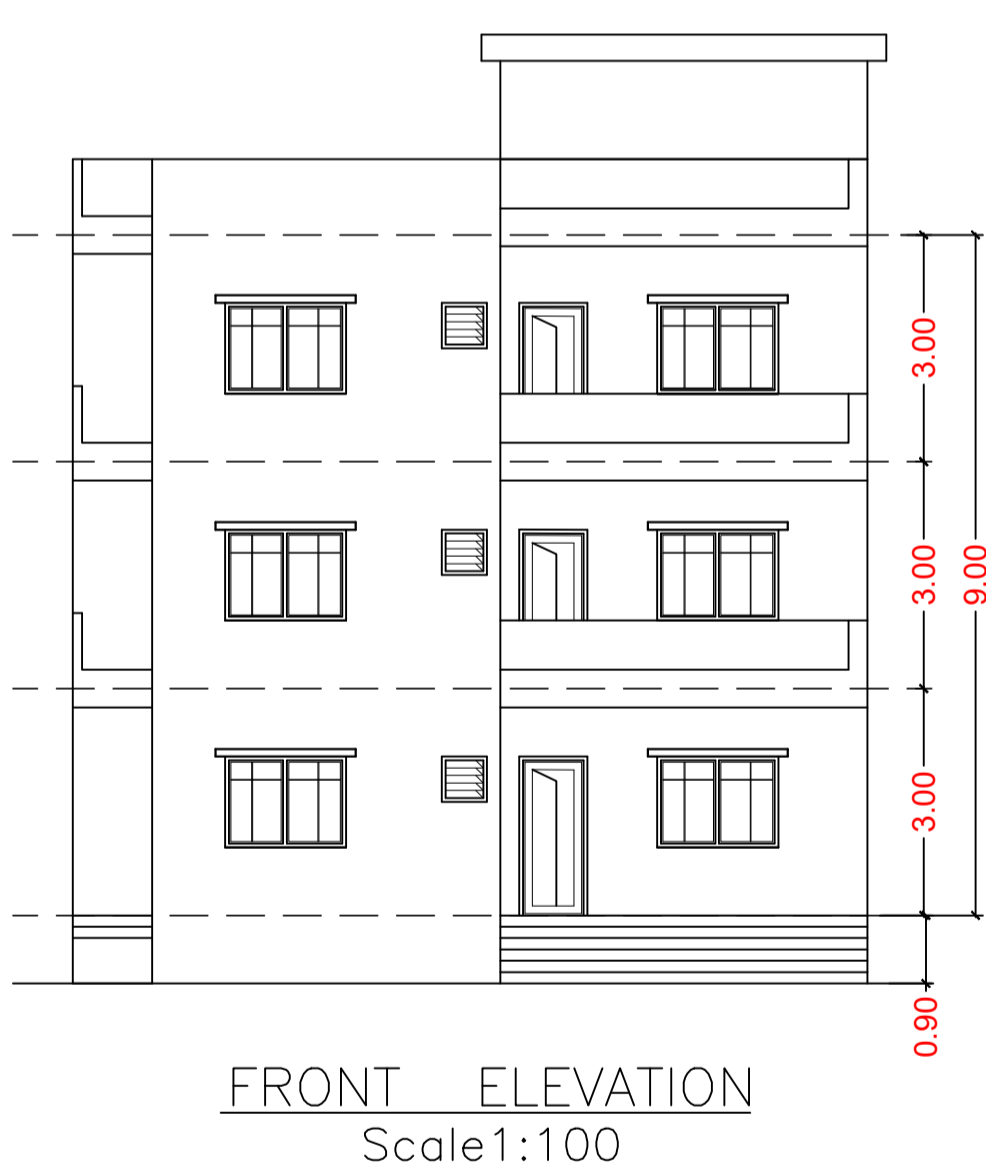
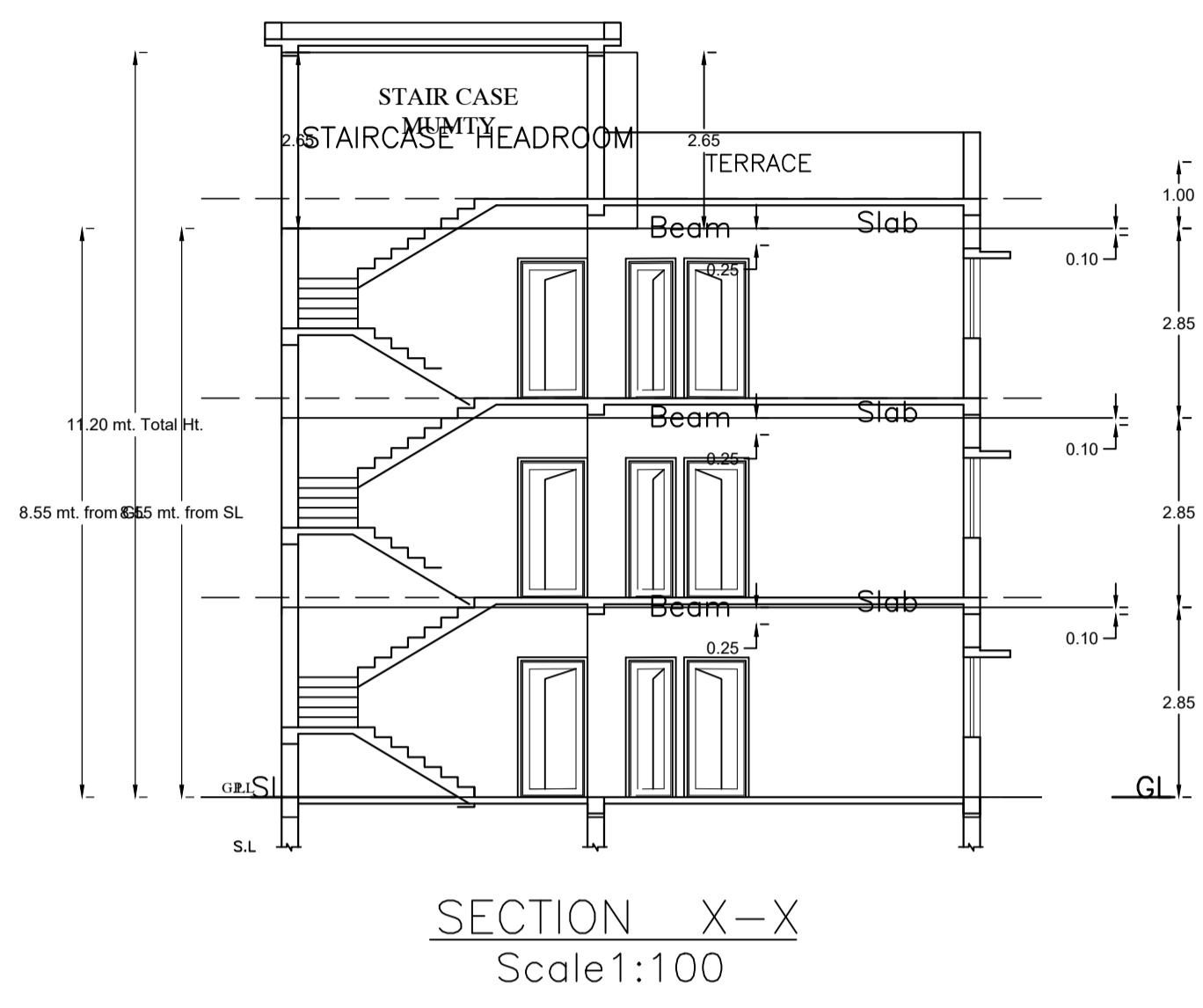
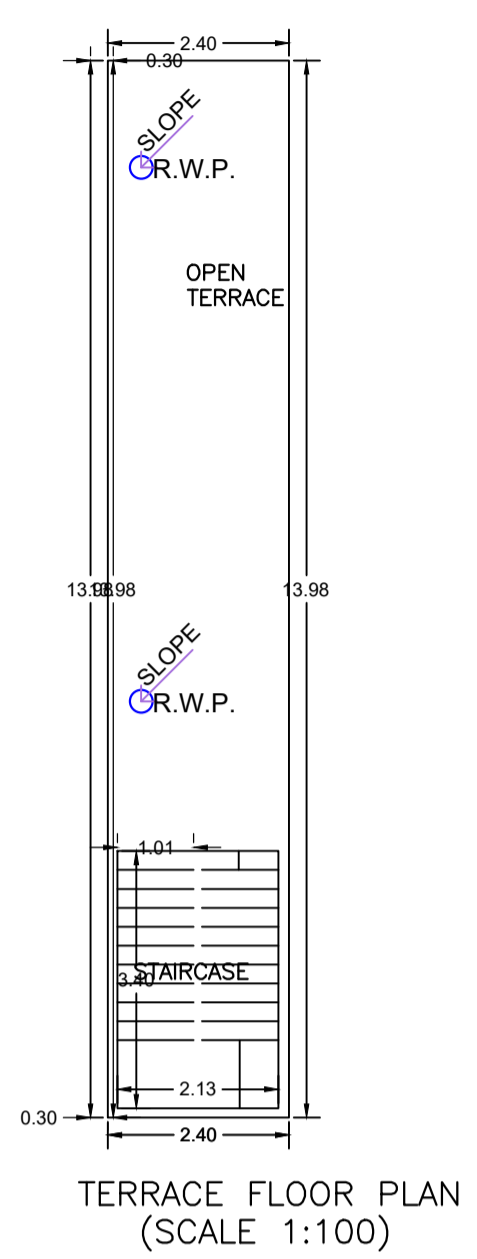
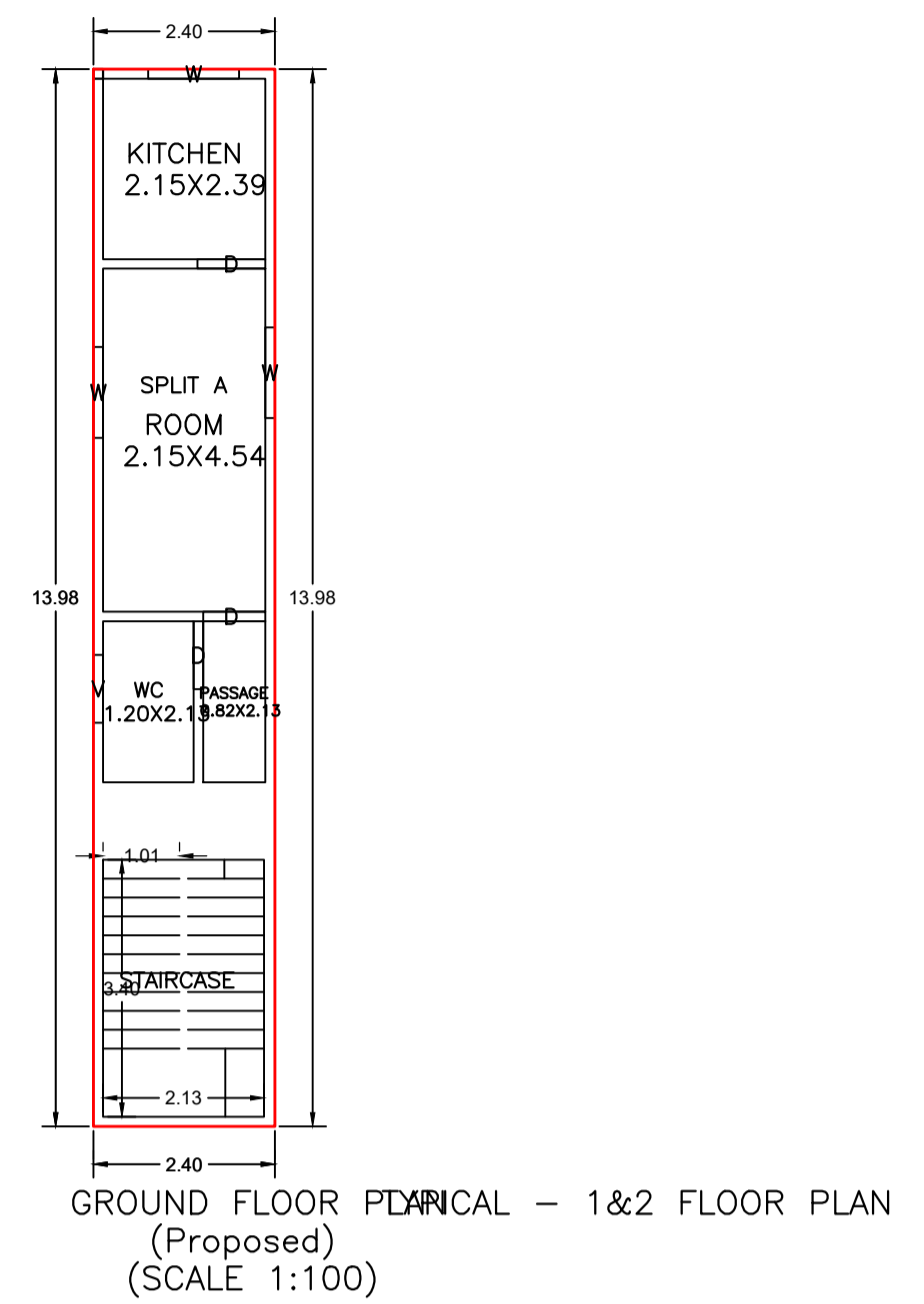
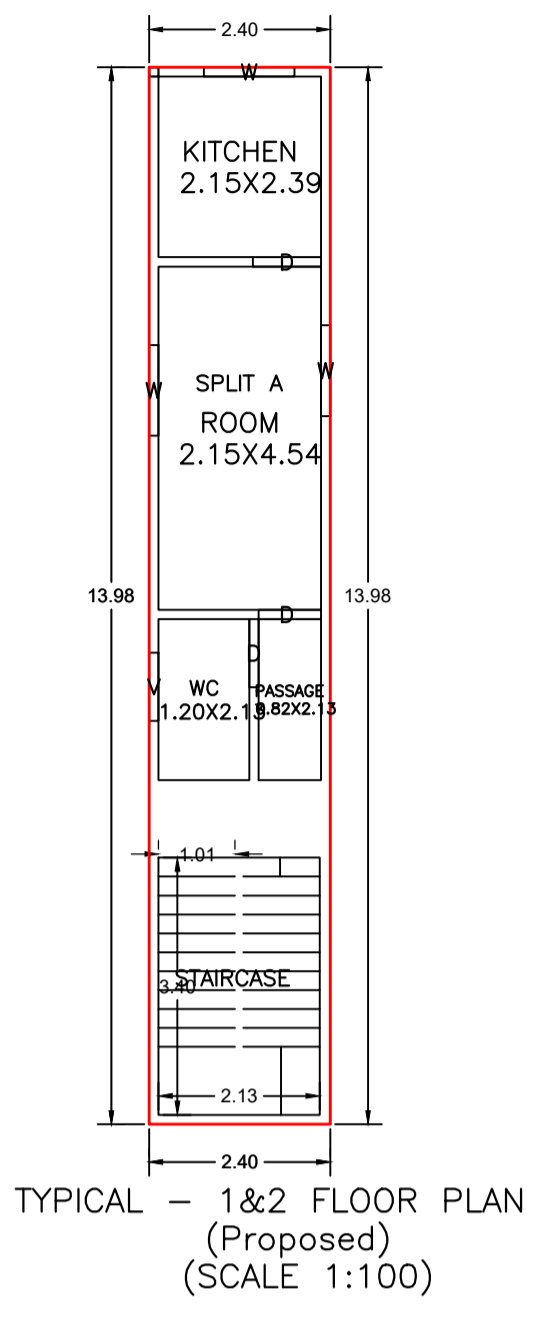
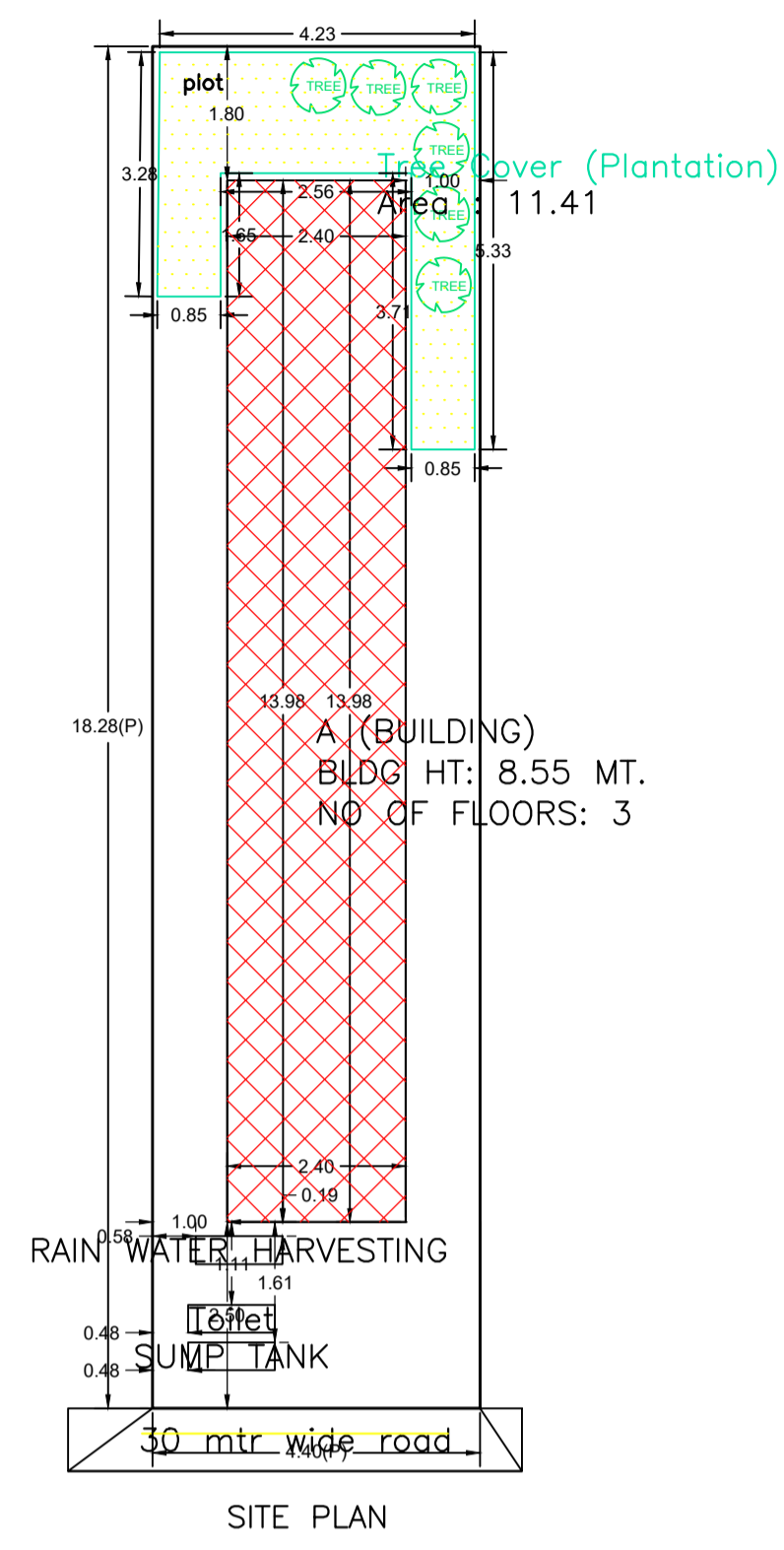

AREA STATEMENT MEDINAGAR MUNICIPAL CORPORATION	VERSION NO.: 1.0.73	
PROJECT DETAIL:	VERSION DATE: 16/10/2020	
Region: JHARKHAND URBAN LOCAL BODIES	Plot Use: Residential	
District: PALAMU	Plot SubUse: Bungalow/ Dwelling / Non Apartment	
Authority: MEDINAGAR MUNICIPAL CORPORATION	PlotNearby/ReligiousStructure: NA	
Inward No: MNNP/BI/0232/W02/2024	Plot/SubPlot No: 231/235	
Application Type: General Proposal	North: -	
Project Type: Building Permission	South: -	
Nature of Development: New	East: -	
Location of Development Area: New Area	West: -	
AREA DETAILS:	SQ.MT.	
AREA OF PLOT (Minimum)	(A)	80.38
NET AREA OF PLOT(Gross Plot Area - Deduction from Gross Plot area)	(A-Deductions)	80.38
Deduction for Balance Plot Area(from Gross Plot Area)		
Common Plot		11.41
Total		11.41
BALANCE AREA OF PLOT(Net Plot Area - Recreational/Amenity space)	(A-Deductions)	68.96
PLOT AREA FOR COVERAGE(Net Plot Area)	(A-Deductions)	80.38
Plot Area for FAR (Net Plot Area + RoadWidening Area)	(A-Deductions)	80.38
COVERAGE CHECK		
Permissible Coverage area (70.00 %)		56.27
Proposed Coverage Area (41.69 %)		33.51
Total Prop. Coverage Area (41.69 %)		33.51
Balance coverage area (28.32 %)		22.76
FAR CHECK		
Perm. FAR Area (2.500)		200.95
Total Perm. FAR area		200.95
Residential FAR		100.53
Proposed FAR Area		100.53
Total Proposed FAR Area		100.53
Consumed FAR (Factor)		1.25
Balance FAR Area		100.42
BUILT UP AREA CHECK		
Total Proposed BuiltUp Area		100.53
ARCHITECT (Regd)		PANKAJ KUMAR SINGH
ENGINEER (Regd)		
SUPERVISOR (Regd)		
OWNER (Regd)		ANITA DEVI
DEVELOPMENT AUTHORITY		LOCAL BODY

COLOR INDEX	
PLOT BOUNDARY	Black
ABUTTING ROAD	Green
PROPOSED CONSTRUCTION	Red
COMMON PLOT	Yellow
ROAD WIDENING AREA	Blue
EXISTING (To be retained)	Orange
EXISTING (To be demolished)	Grey

Floor Name	Building Name A (BUILDING)		Total	
	Proposed Built Up Area (Sq.mt.)	Proposed FAR Area (Sq.mt.)	Total Proposed Built Up Area (Sq.mt.)	Total FAR Area (Sq.mt.)
Ground Floor	33.51	33.51	33.51	33.51
First Floor	33.51	33.51	33.51	33.51
Second Floor	33.51	33.51	33.51	33.51
Terrace Floor	0.00	0.00	0.00	0.00
Total:	100.53	100.53	100.53	100.53

Building USE/SUBUSE Details

Building Name	Building Use	Building SubUse	Building Structure	Floor Name	Floor Use	Floor SubUse	FAR Name	FAR Use	FAR SubUse
A (BUILDING)	Residential	Bungalow/ Dwelling / Non Apartment	Non-Highrise	TYPICAL - 1&2 FLOOR PLAN	Residential	Bungalow/ Dwelling / Non Apartment	Residential FAR	Residential	Bungalow/ Dwelling / Non Apartment
				GROUND FLOOR PLAN	Residential	Bungalow/ Dwelling / Non Apartment	Residential FAR	Residential	Bungalow/ Dwelling / Non Apartment
				TERRACE FLOOR PLAN	Residential	Bungalow/ Dwelling / Non Apartment	-	-	-

UnitBUA Table for Building :A (BUILDING)

FLOOR	Name	UnitBUA Type	UnitBUA Area	Carpet Area	No. of Rooms	No. of Tenement
TYPICAL - 1&2 FLOOR PLAN	SPLIT A	FLAT	0.00	0.00	4	0
GROUND FLOOR PLAN	SPLIT A	FLAT	68.71	68.67	4	1
Total:	-	-	68.71	68.67	12	1

SCHEDULE OF DOOR:

BUILDING NAME	NAME	LENGTH	HEIGHT	NOS
A (BUILDING)	D	0.82	2.10	03
A (BUILDING)	D	0.90	2.10	06

SCHEDULE OF WINDOW/VENTILATION:

BUILDING NAME	NAME	LENGTH	HEIGHT	NOS
A (BUILDING)	V	0.90	0.60	03
A (BUILDING)	W	1.20	1.20	09

Building :A (BUILDING)

Floor Name	Total Built Up Area (Sq.mt.)	Proposed FAR Area (Sq.mt.) Resi.	Total FAR Area (Sq.mt.)	Total Consumed Additional FAR Area (Sq.mt.)	Tnmt (No.)
Ground Floor	33.51	33.51	33.51	33.51	01
First Floor	33.51	33.51	33.51	33.51	00
Second Floor	33.51	33.51	33.51	33.51	00
Terrace Floor	0.00	0.00	0.00	0.00	00
Total :	100.53	100.53	100.53	100.53	01
Total Number of Same Buildings :	1				
Total :	100.53	100.53	100.53	100.53	01

FAR & Tenement Details (Table 4c-1)

Building	No. of Same Bldg	Total Built Up Area (Sq.mt.)	Proposed FAR Area (Sq.mt.) Resi.	Total FAR Area (Sq.mt.)	Total Consumed Additional FAR Area (Sq.mt.)	Tnmt (No.)
A (BUILDING)	1	100.53	100.53	100.53	100.53	01
Grand Total :	1	100.53	100.53	100.53	100.53	01

LTP NAME AND SIGNATURE	STRUCTURAL ENG'S NAME AND SIGNATURE	BUILDER NAME AND SIGNATURE	DIGITAL SIGNATURE
PANKAJ KUMAR SINGH MNNP/ENG/0006/2019			