

Proposal Basic Information

Proposal File No.	MNNP/BP/0222/W03/2024
Owner Name	SUMANTI DEVI & SHOBHA DEVI
Khata No	72
Plot No	344
Village Name	Sudma Bariya
Use	Residential
SubUse	Bungalow/ Dwelling / Non Apartment

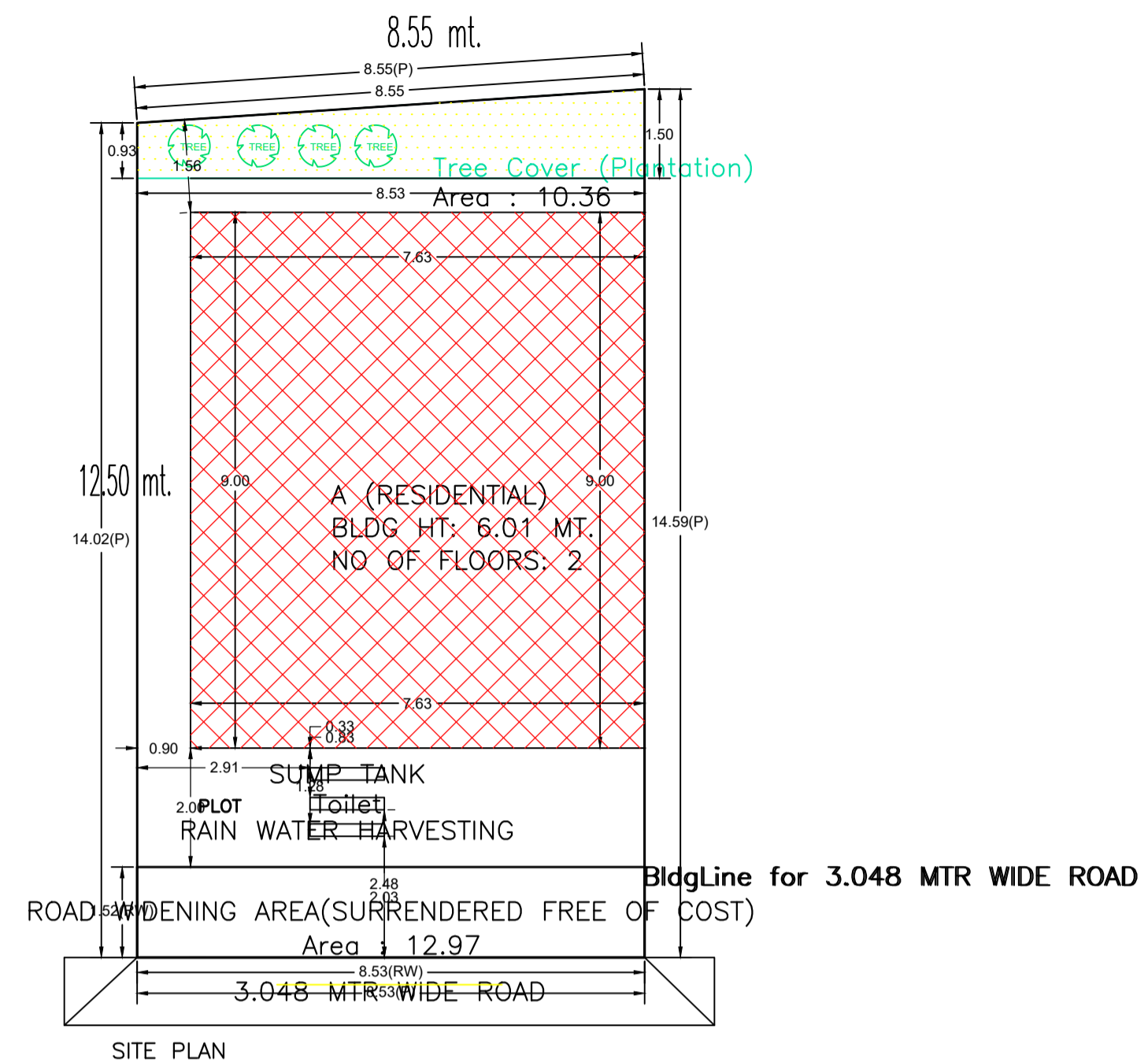

Building USE/SUBUSE Details

Building Name	Building Use	Building SubUse	Building Structure	Floor Name	Floor Use	Floor SubUse	FAR Name	FAR Use	FAR SubUse
A (RESIDENTIAL)	Residential	Bungalow/ Dwelling / Non Apartment	Non-Highrise	TERRACE FLOOR PLAN	Residential	Bungalow/ Dwelling / Non Apartment	-	-	-
				FIRST FLOOR PLAN	Residential	Bungalow/ Dwelling / Non Apartment	Residential FAR	Residential	Bungalow/ Dwelling / Non Apartment
				GROUND FLOOR PLAN	Residential	Bungalow/ Dwelling / Non Apartment	Residential FAR	Residential	Bungalow/ Dwelling / Non Apartment

AREA STATEMENT MEDINAGAR MUNICIPAL CORPORATION	VERSION NO.: 1.0.73 VERSION DATE: 16/10/2020		
PROJECT DETAIL:			
Region: JHARKHAND URBAN LOCAL BODIES	Plot Use: Residential		
District: PALAMU	Plot SubUse: Bungalow/ Dwelling / Non Apartment		
Authority: MEDINAGAR MUNICIPAL CORPORATION	PlotNearby/ReligiousStructure: NA		
Inward_No: MNNP/BP/0222/W03/2024	Plot/SubPlot No: 344		
Application Type: General Proposal	North: -		
Project Type: Building Permission	South: -		
Nature of Development: New	East: -		
Location of Development Area: New Area	West: -		
AREA DETAILS:			
AREA OF PLOT (Minimum)	(A)	SQ.MT.	121.44
Deduction for NetPlot Area			
Surrender Free of Cost			
Total			
NET AREA OF PLOT(Gross Plot Area - Deduction from Gross Plot area)			
(A-Deductions)			
108.47			
Deduction for Balance Plot Area(from Gross Plot Area)			
Surrender Free of Cost			
Common Plot			
Total			
BALANCE AREA OF PLOT(Net Plot Area - Recreational/Amenity space)			
(A-Deductions)			
98.11			
PLOT AREA FOR COVERAGE(Net Plot Area)			
(A-Deductions)			
108.47			
Plot Area for FAR (Net Plot Area + Road/Widening Area)			
(A-Deductions)			
121.44			
COVERAGE CHECK			
Permissible Coverage area ( 70.00 % )			
75.93			
Proposed Coverage Area ( 63.31 % )			
68.67			
Total Prop. Coverage Area ( 63.31 % )			
68.67			
Balance coverage area ( 6.69 % )			
7.26			
FAR CHECK			
Perm. FAR Area ( 1.200 )			
145.73			
Total Perm. FAR area			
145.73			
Residential FAR			
137.34			
Proposed FAR Area			
137.34			
Total Proposed FAR Area			
137.34			
Consumed FAR (Factor)			
1.13			
Balance FAR Area			
8.39			
BUILT UP AREA CHECK			
Total Proposed BuiltUp Area			
137.34			
ARCHITECT (Regd)	Umesh Prasad		
ENGINEER (Regd)			
SUPERVISOR (Regd)			
OWNER (Regd)	SUMANTI DEVI & SHOBHA DEVI		
DEVELOPMENT AUTHORITY			
LOCAL BODY			

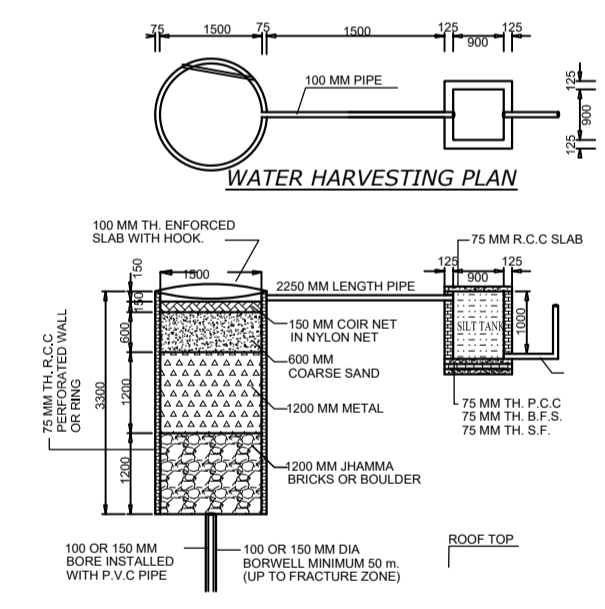
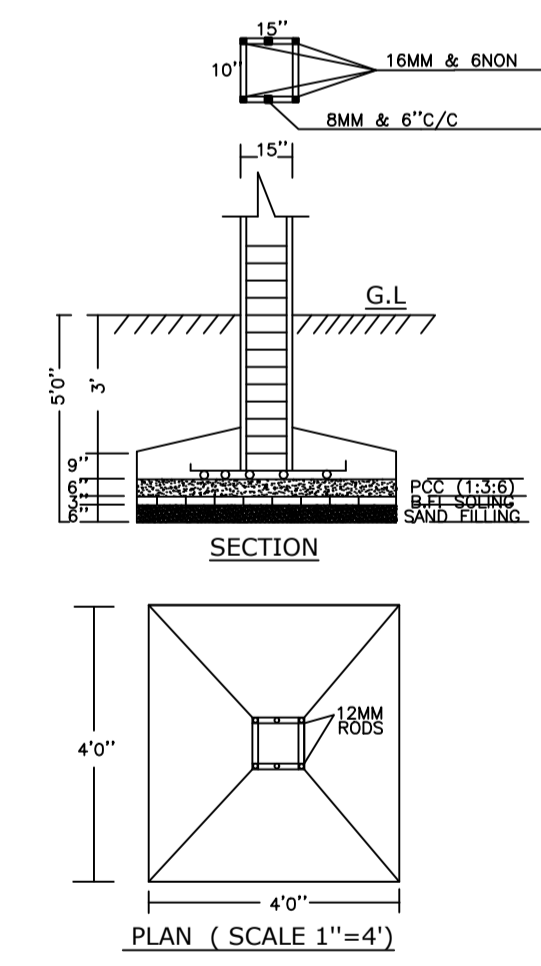
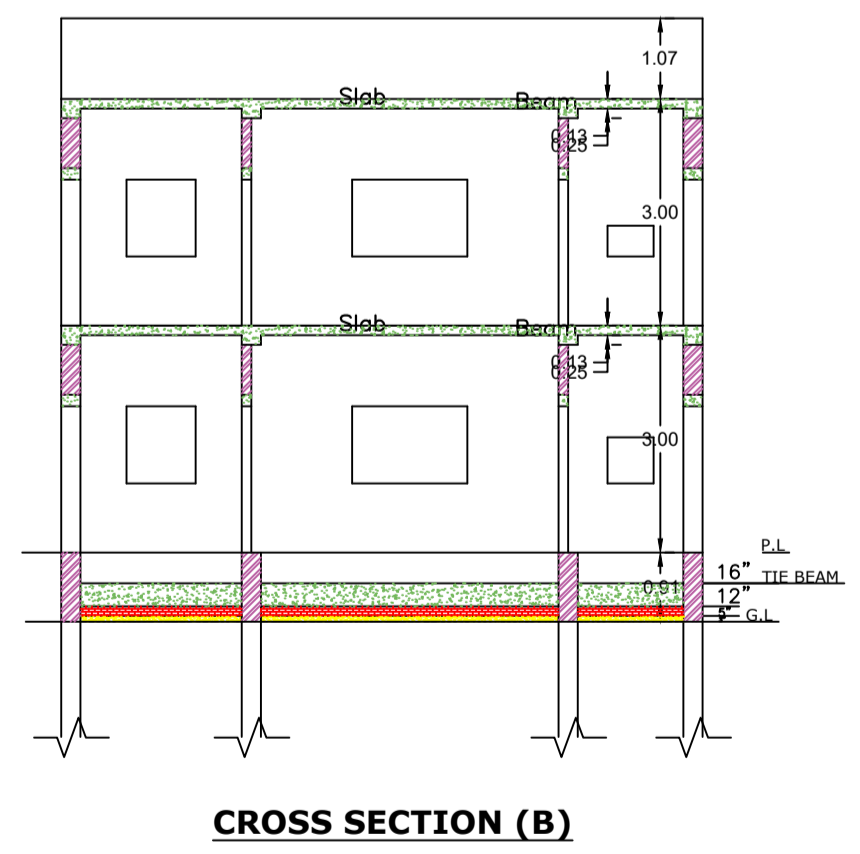
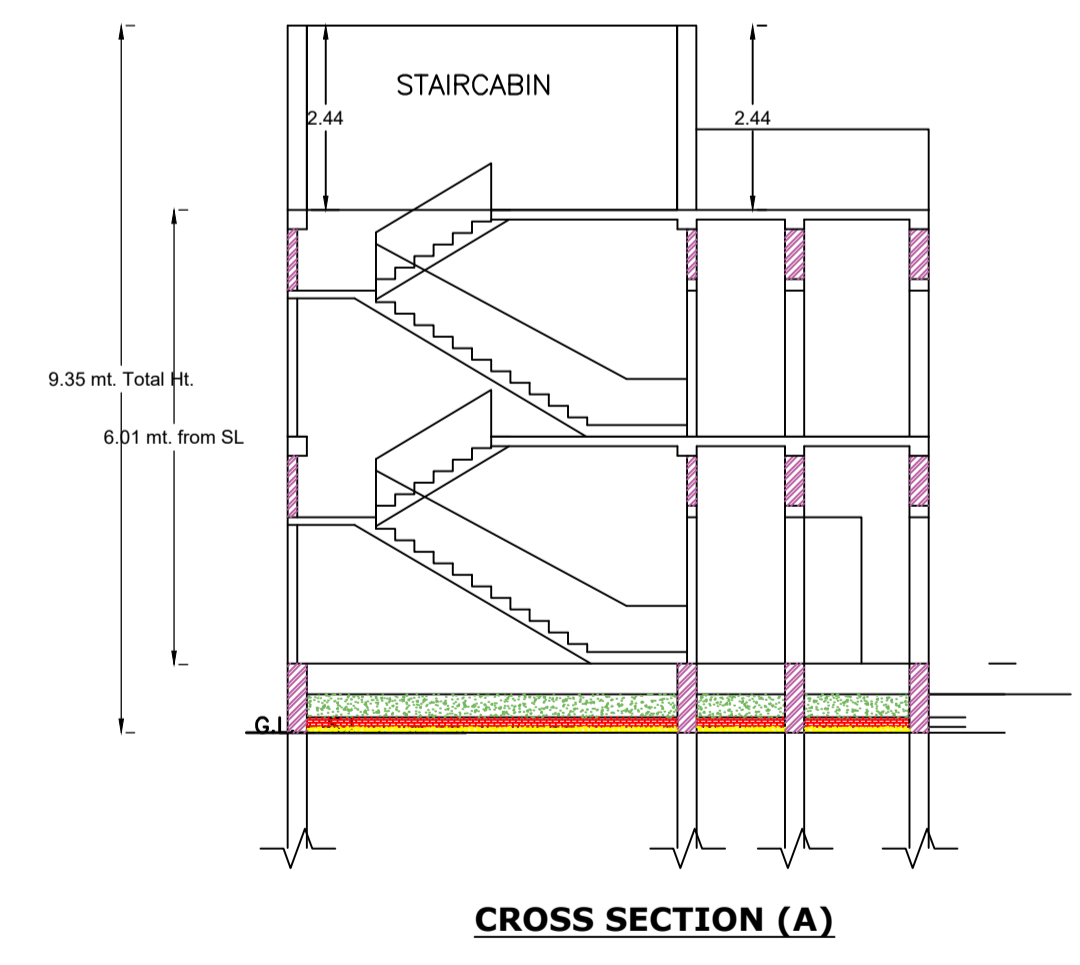
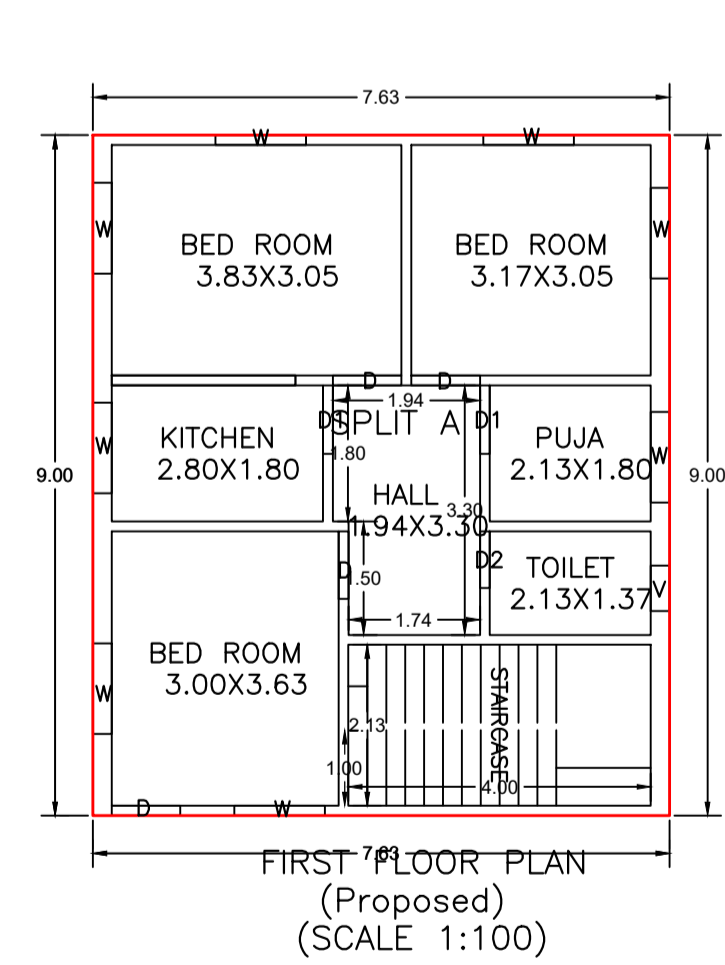
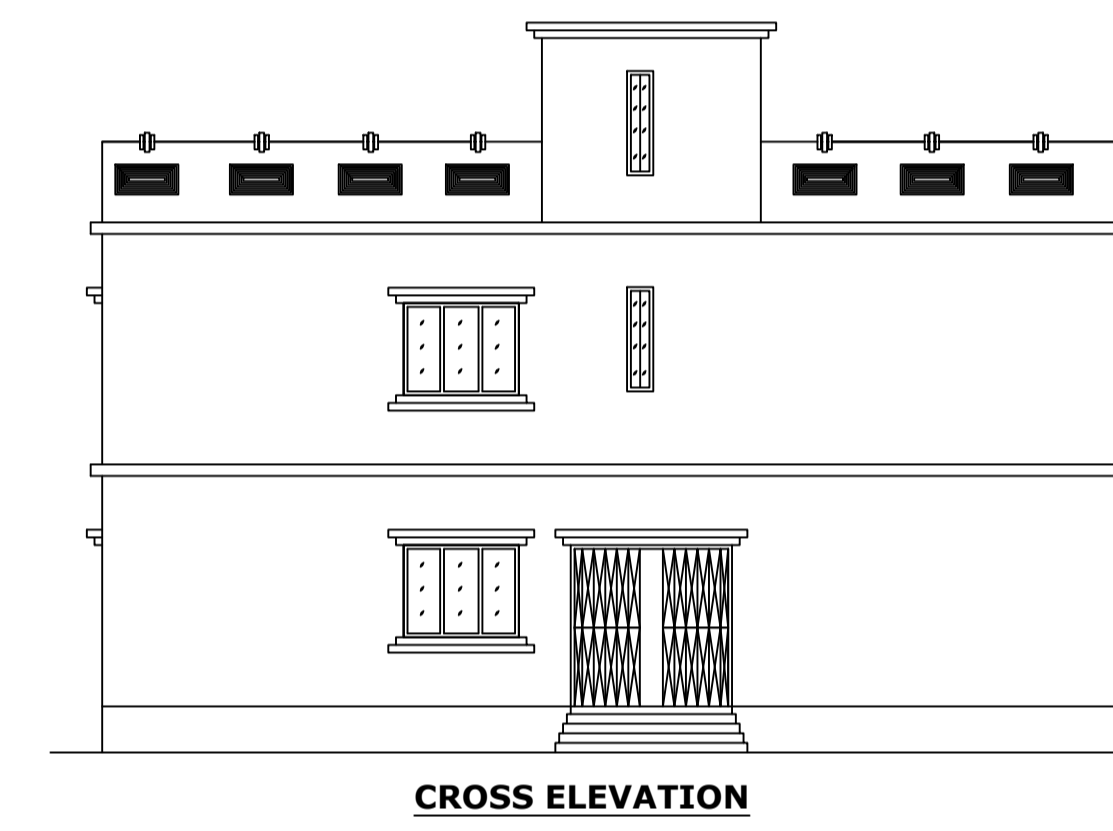
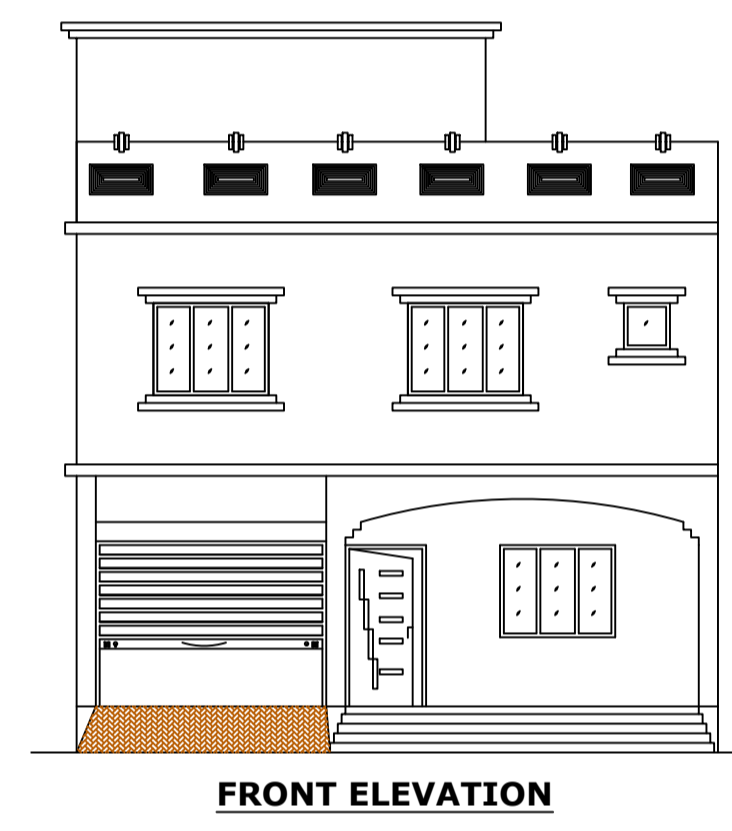
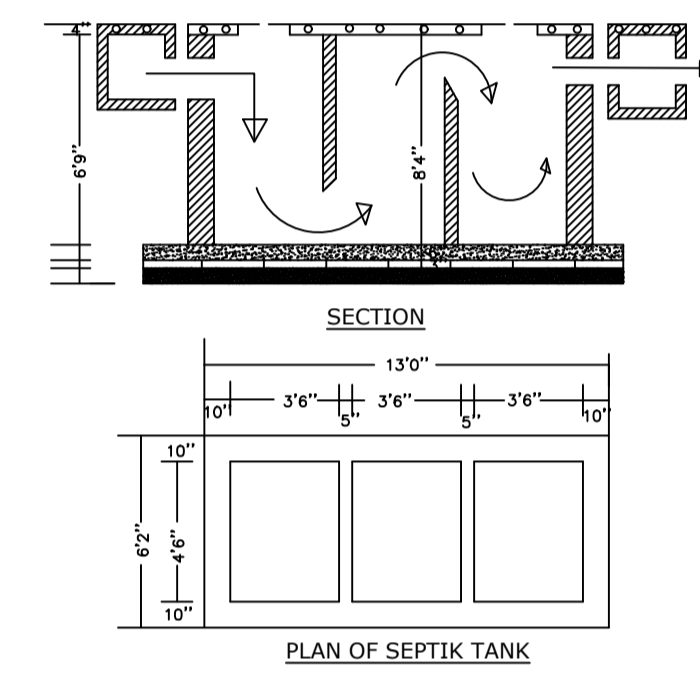
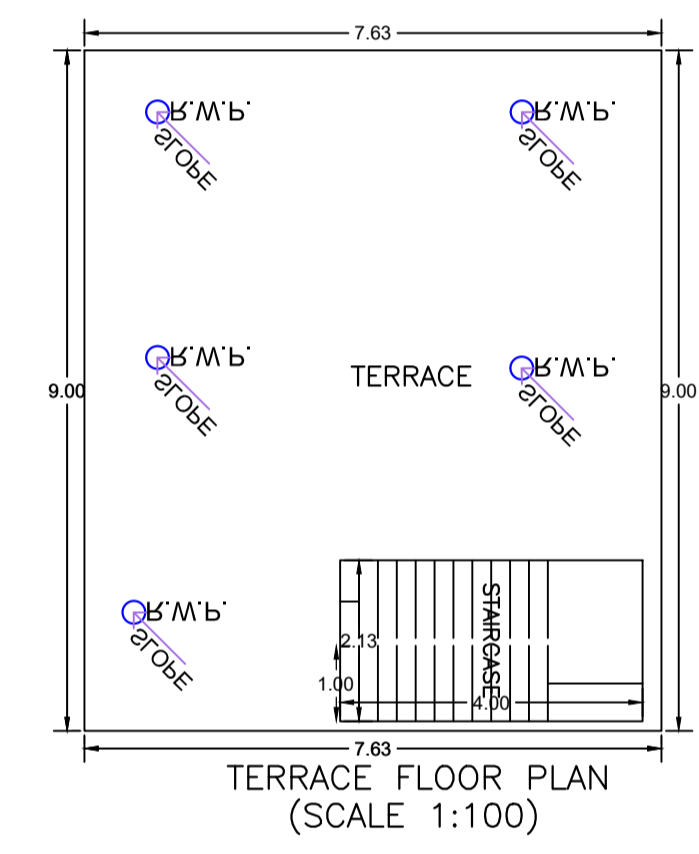
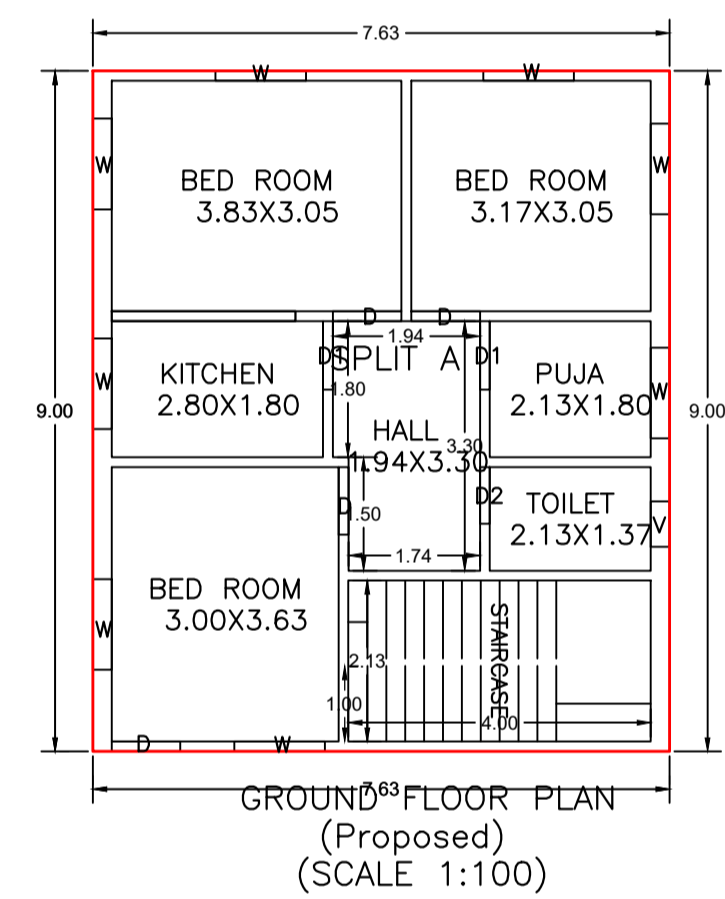

COLOR INDEX	
PLOT BOUNDARY	[Red Line]
ABUTTING ROAD	[Green Line]
PROPOSED CONSTRUCTION	[Yellow Line]
COMMON PLOT	[Blue Line]
ROAD WIDENING AREA	[Orange Line]
EXISTING (To be retained)	[Grey Line]
EXISTING (To be demolished)	[Black Line]

Buildingwise Floor FAR Details

Floor Name	Building Name A (RESIDENTIAL)		Total	
	Proposed Built Up Area (Sq.mt.)	Proposed FAR Area (Sq.mt.)	Total Proposed Built Up Area (Sq.mt.)	Total FAR Area (Sq.mt.)
Ground Floor	68.67	68.67	68.67	68.67
First Floor	68.67	68.67	68.67	68.67
Terrace Floor	0.00	0.00	0.00	0.00
Total :	137.34	137.34	137.34	137.34

FAR & Tenement Details (Table 4c-1)

Building	No. of Same Bldg	Total Built Up Area (Sq.mt.)	Proposed FAR Area (Sq.mt.)	Total FAR Area (Sq.mt.)	Total Consumed Additional FAR Area (Sq.mt.)	Tnmt (No.)
A (RESIDENTIAL)	1	137.34	137.34	137.34	137.34	01
Grand Total :	1	137.34	137.34	137.34	137.34	01

Building :A (RESIDENTIAL)

Floor Name	Total Built Up Area (Sq.mt.)	Proposed FAR Area (Sq.mt.)	Total FAR Area (Sq.mt.)	Total Consumed Additional FAR Area (Sq.mt.)	Tnmt (No.)
Ground Floor	68.67	68.67	68.67	68.67	01
First Floor	68.67	68.67	68.67	68.67	00
Terrace Floor	0.00	0.00	0.00	0.00	00
Total :	137.34	137.34	137.34	137.34	01
Total Number of Same Buildings :	1				
Total :	137.34	137.34	137.34	137.34	01

SCHEDULE OF DOOR:

BUILDING NAME	NAME	LENGTH	HEIGHT	NOS
A (RESIDENTIAL)	D2	0.75	2.10	02
A (RESIDENTIAL)	D	0.90	2.10	02
A (RESIDENTIAL)	D	0.91	2.10	06
A (RESIDENTIAL)	D1	0.91	2.10	04

UnitBUA Table for Building :A (RESIDENTIAL)

FLOOR	Name	UnitBUA Type	UnitBUA Area	Carpet Area	No. of Rooms	No. of Tenement
FIRST FLOOR PLAN	SPLIT A	FLAT	0.00	0.00	7	0
GROUND FLOOR PLAN	SPLIT A	FLAT	118.13	117.50	7	1
Total:	-	-	118.13	117.50	14	1

SCHEDULE OF WINDOW/VENTILATION:

BUILDING NAME	NAME	LENGTH	HEIGHT	NOS
A (RESIDENTIAL)	V	0.60	0.90	02
A (RESIDENTIAL)	W	1.20	1.20	16

LTP NAME AND SIGNATURE	STRUCTURAL ENG'S NAME AND SIGNATURE	BUILDER NAME AND SIGNATURE	DIGITAL SIGNATURE
Umesh Prasad MNNP/ENG/0002/2024			