

| Proposal Basic Information |                                    |
|----------------------------|------------------------------------|
| Proposal File No.          | MNNP/BP/0224/W02/2024              |
| Owner Name                 | Sunil Kumar Gupta                  |
| Khata No                   | 01                                 |
| Plot No                    | 249                                |
| Village Name               | Sudma Bariya                       |
| Use                        | Residential                        |
| SubUse                     | Bungalow/ Dwelling / Non Apartment |

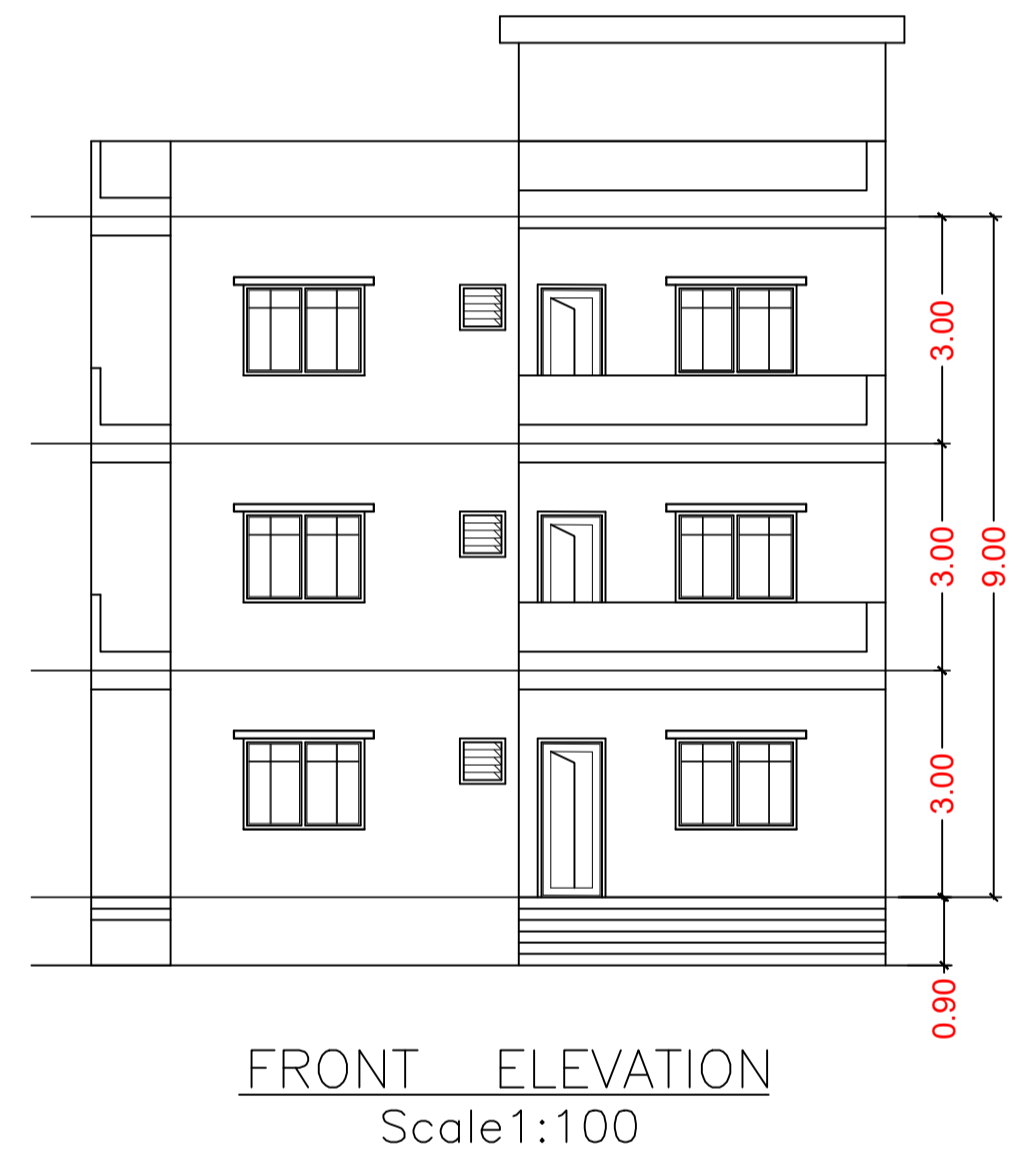
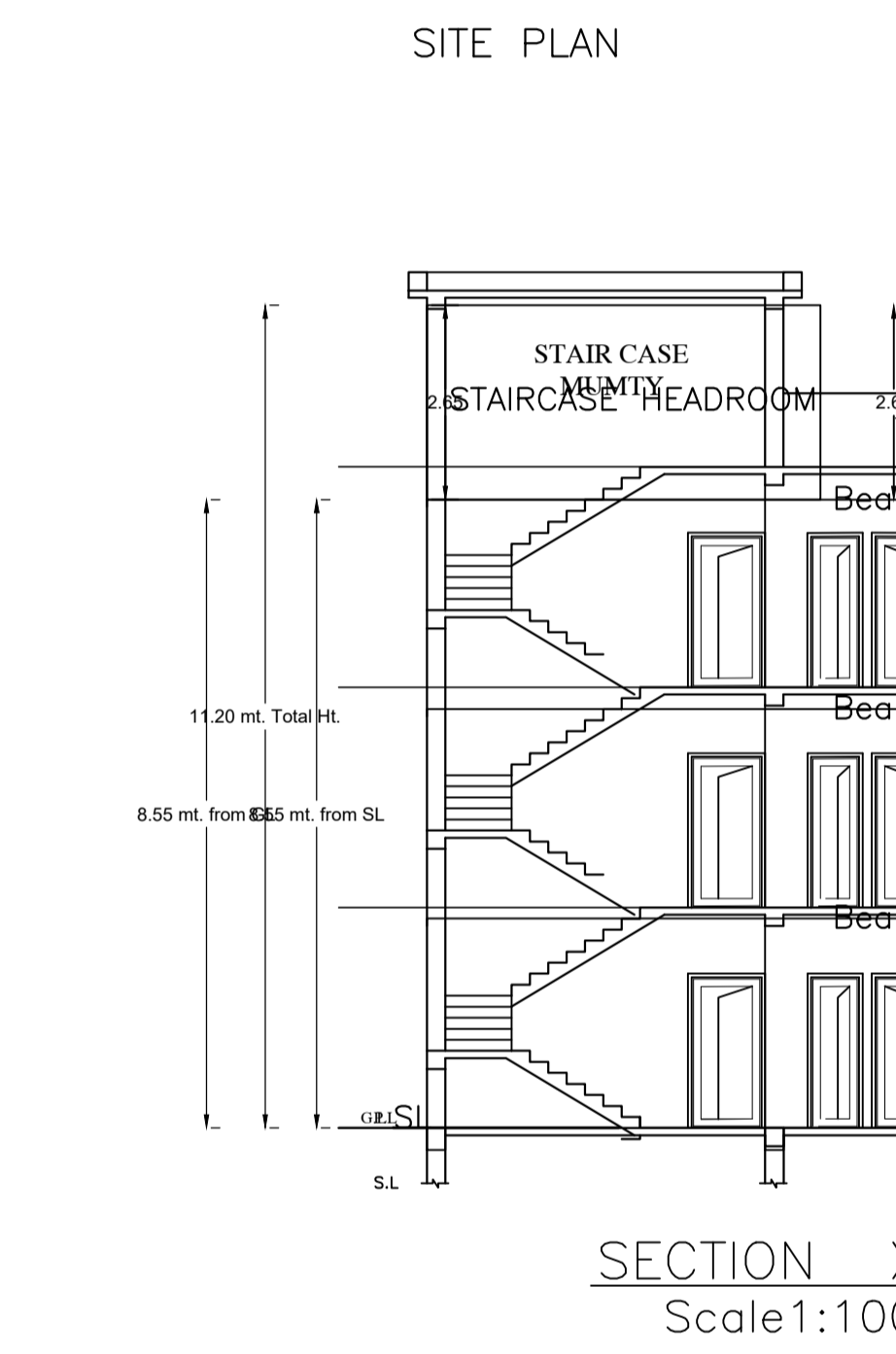
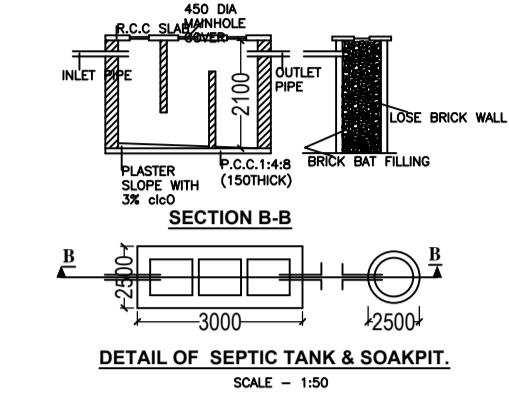
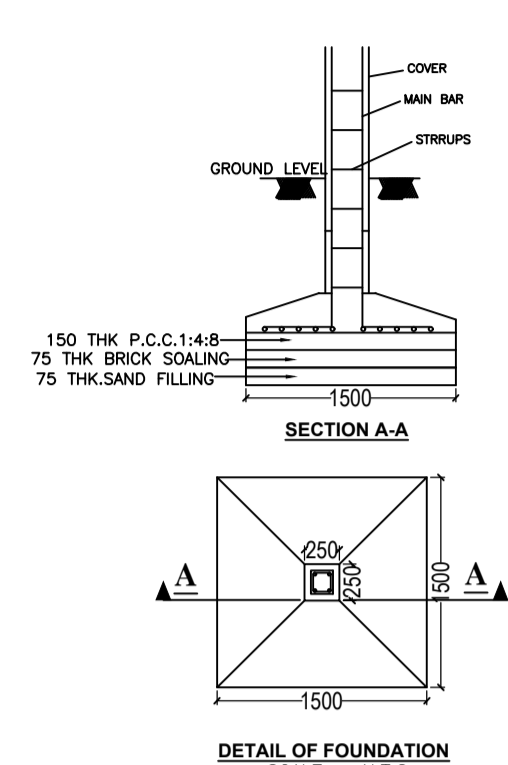
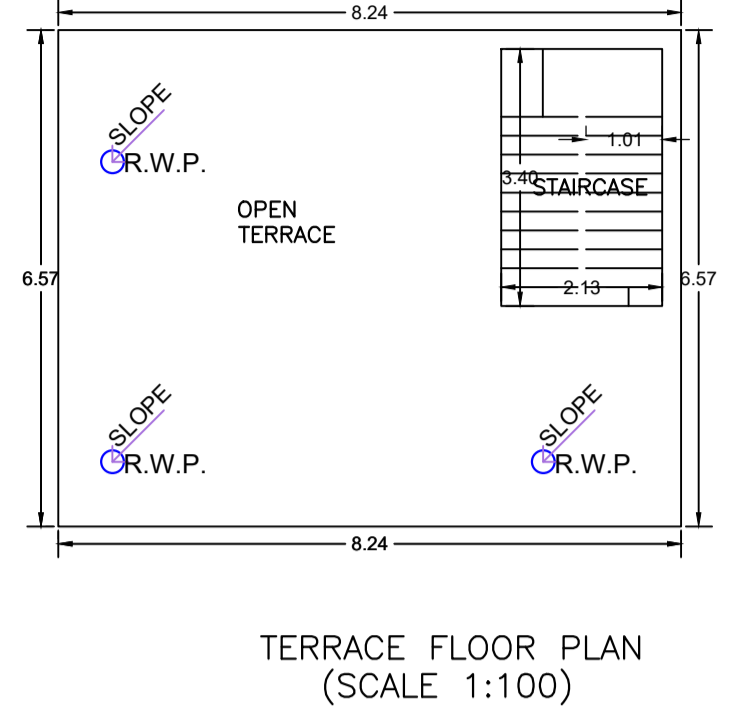
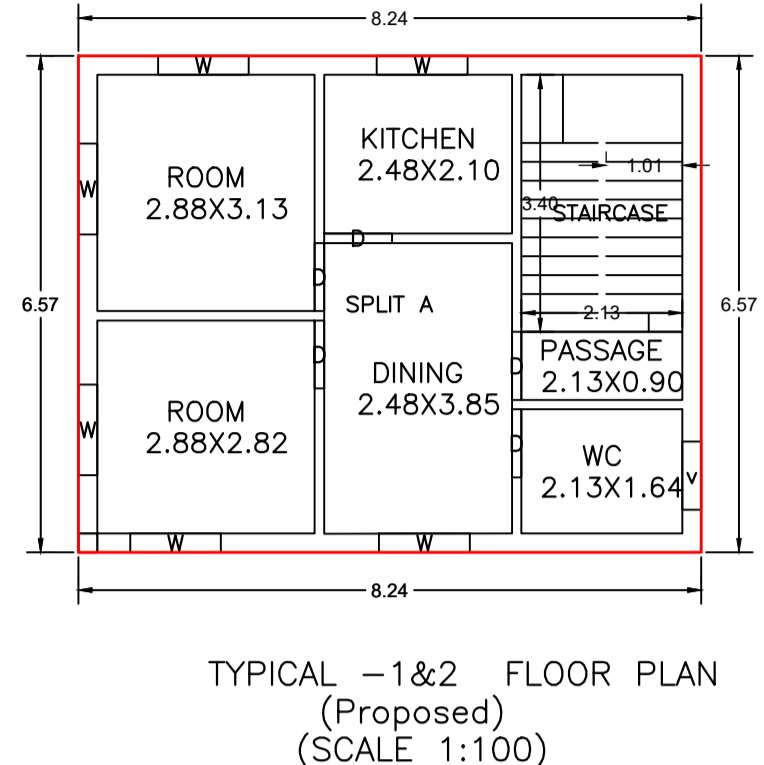
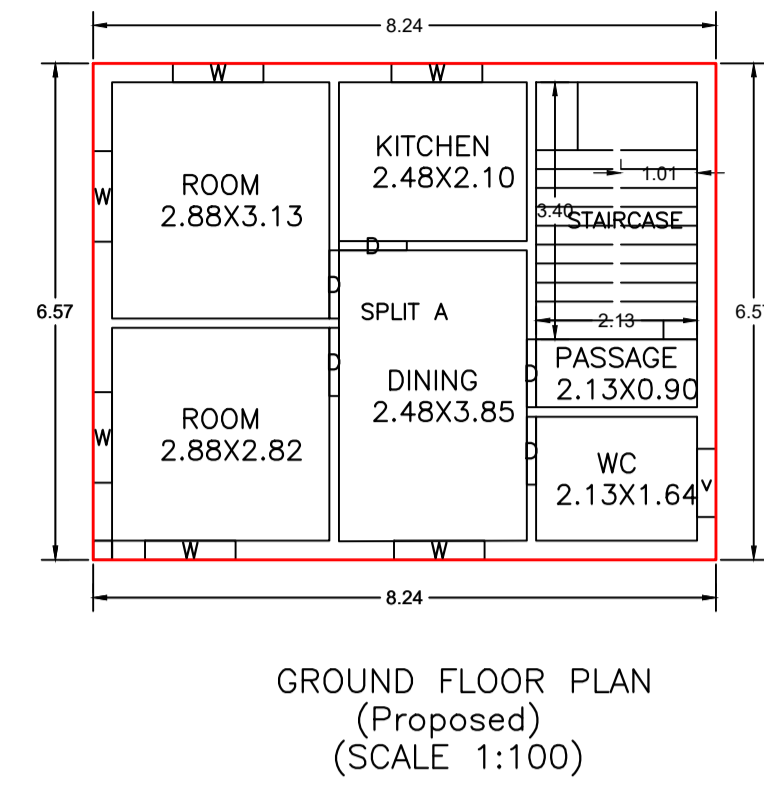
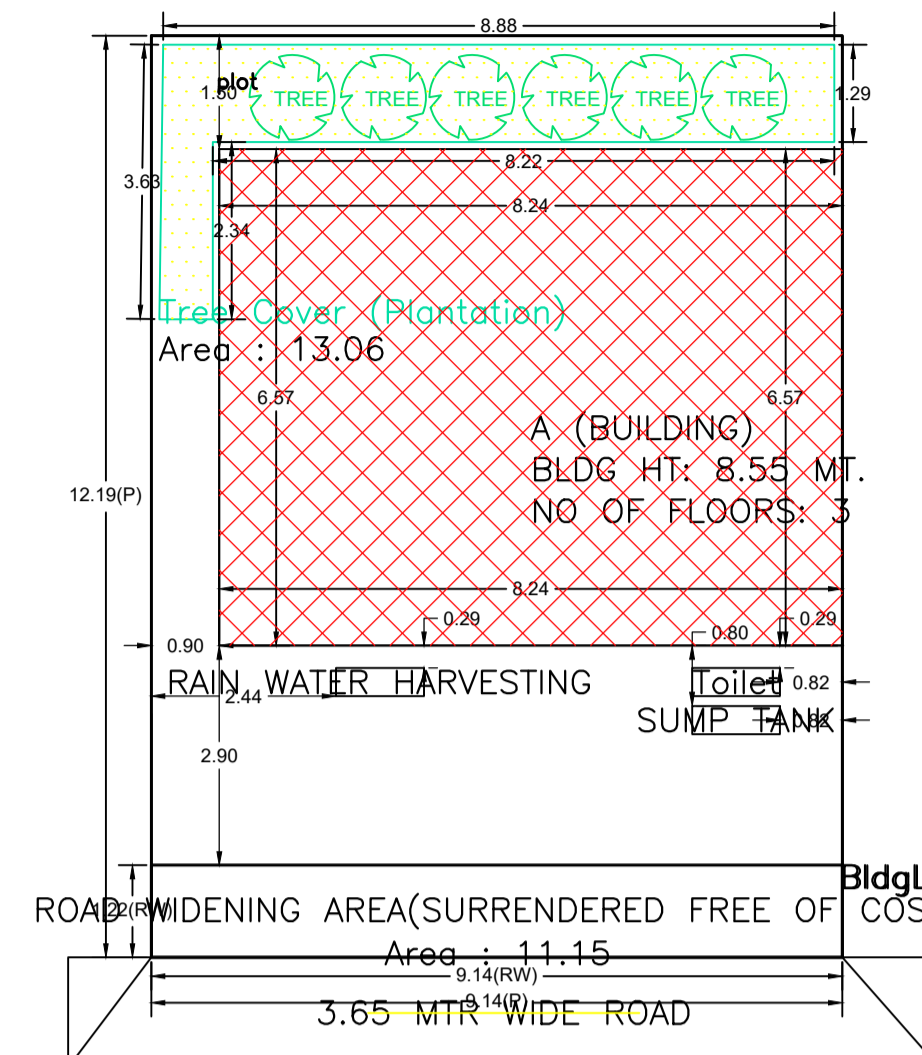

| AREA STATEMENT  |   | VERSION NO. : 1.0.73     |
|---|---|--------------------------|
| MEDININAGAR MUNICIPAL CORPORATION                                   |   | VERSION DATE: 16/10/2020 |
| PROJECT DETAIL:   |   |                          |
| Region: JHARKHAND URBAN   | Plot Use: Residential                           |                          |
| Local Bodies: PALAMU  | Plot SubUse: Bungalow/ Dwelling / Non Apartment |                          |
| Authority: MEDININAGAR MUNICIPAL CORPORATION                        | PlotNearbyReligiousStructure: NA                |                          |
| Inward No: MNNP/BP/0224/W02/2024                                    | Plot/SubPlot No: 249                            |                          |
| Application Type: General Proposal                                  | North: -  |                          |
| Project Type: Building Permission                                   | South: -  |                          |
| Nature of Development: New  | East: -   |                          |
| Location of Development Area: New                                   | West: -   |                          |
| <b>AREA DETAILS:</b>  |   |                          |
| AREA OF PLOT (Minimum)  | (A)   | 111.42                   |
| Deduction for NetPlot Area  |   |                          |
| Surrender Free of Cost  |   | 11.15                    |
| Total   |   | 11.15                    |
| NET AREA OF PLOT (Gross Plot Area - Deduction from Gross Plot Area) | (A-Deductions)                                  | 100.27                   |
| Deduction for Balance Plot Area (from Gross Plot Area)              |   |                          |
| Surrender Free of Cost  |   | 11.15                    |
| Common Plot   |   | 13.06                    |
| Total   |   | 24.21                    |
| BALANCE AREA OF PLOT (Net Plot Area - Recreational/Amenity spaces)  | (A-Deductions)                                  | 87.20                    |
| PLOT AREA FOR COVERAGE (Net Plot Area)                              | (A-Deductions)                                  | 100.27                   |
| Plot Area for FAR (Net Plot Area + Road Widening Area)              | (A-Deductions)                                  | 111.42                   |
| <b>COVERAGE CHECK</b>   |   |                          |
| Permissible Coverage area ( 70.00 % )                               |   | 70.19                    |
| Proposed Coverage Area ( 53.96 % )                                  |   | 54.10                    |
| Total Prop. Coverage Area ( 53.96 % )                               |   | 54.10                    |
| Balance coverage area ( 16.05 % )                                   |   | 16.09                    |
| <b>FAR CHECK</b>  |   |                          |
| Perm. FAR Area ( 1.500 )  |   | 167.13                   |
| Total Perm. FAR area  |   | 167.13                   |
| Residential FAR   |   | 162.31                   |
| Proposed FAR Area   |   | 162.31                   |
| Total Proposed FAR Area   |   | 162.31                   |
| Consumed FAR (Factor)   |   | 1.46                     |
| Balance FAR Area  |   | 4.82                     |
| <b>BUILT UP AREA CHECK</b>  |   |                          |
| Total Proposed BuiltUp Area   |   | 162.30                   |
| ARCHITECT (Regd)  | PANKAJ KUMAR SINGH                              |                          |
| ENGINEER (Regd)   |   |                          |
| SUPERVISOR (Regd)   |   |                          |
| OWNER (Regd)  | Sunil Kumar Gupta                               |                          |
| DEVELOPMENT AUTHORITY   |   | LOCAL BODY               |

| COLOR INDEX                 |            |
|-----------------------------|------------|
| PLOT BOUNDARY               | Black      |
| ABUTTING ROAD               | Red        |
| PROPOSED CONSTRUCTION       | Green      |
| COMMON PLOT                 | Yellow     |
| ROAD WIDENING AREA          | Blue       |
| EXISTING (To be retained)   | Orange     |
| EXISTING (To be demolished) | Light Blue |

| Floor Name    | Building Name A (BUILDING)      |                            | Total                                 |                         |
|---------------|---------------------------------|----------------------------|---------------------------------------|-------------------------|
|               | Proposed Built Up Area (Sq.mt.) | Proposed FAR Area (Sq.mt.) | Total Proposed Built Up Area (Sq.mt.) | Total FAR Area (Sq.mt.) |
| Ground Floor  | 54.10                           | 54.10                      | 54.10                                 | 54.10                   |
| First Floor   | 54.10                           | 54.10                      | 54.10                                 | 54.10                   |
| Second Floor  | 54.10                           | 54.10                      | 54.10                                 | 54.10                   |
| Terrace Floor | 0.00                            | 0.00                       | 0.00                                  | 0.00                    |
| Total :       | 162.30                          | 162.30                     | 162.30                                | 162.30                  |

**SCHEDULE OF DOOR:**

| BUILDING NAME | NAME | LENGTH | HEIGHT | NOS |
|---------------|------|--------|--------|-----|
| A (BUILDING)  | D    | 0.90   | 2.10   | 15  |

**SCHEDULE OF WINDOW/VENTILATION:**

| BUILDING NAME | NAME | LENGTH | HEIGHT | NOS |
|---------------|------|--------|--------|-----|
| A (BUILDING)  | v    | 0.90   | 0.60   | 03  |
| A (BUILDING)  | w    | 1.20   | 1.20   | 18  |

**Building :A (BUILDING)**

| Floor Name                       | Total Built Up Area (Sq.mt.) | Proposed FAR Area (Sq.mt.) Resi. | Total FAR Area (Sq.mt.) | Total Consumed Additional FAR Area (Sq.mt.) | Tnmt (No.) |
|----------------------------------|------------------------------|----------------------------------|-------------------------|---|------------|
| Ground Floor                     | 54.10                        | 54.10                            | 54.10                   | 54.10                                       | 01         |
| First Floor                      | 54.10                        | 54.10                            | 54.10                   | 54.10                                       | 00         |
| Second Floor                     | 54.10                        | 54.10                            | 54.10                   | 54.10                                       | 00         |
| Terrace Floor                    | 0.00                         | 0.00                             | 0.00                    | 0.00  | 00         |
| Total :                          | 162.30                       | 162.30                           | 162.30                  | 162.30                                      | 01         |
| Total Number of Same Buildings : | 1                            |                                  |                         |   |            |
| Total :                          | 162.30                       | 162.30                           | 162.30                  | 162.30                                      | 01         |

**UnitBUA Table for Building :A (BUILDING)**

| FLOOR                   | Name    | UnitBUA Type | UnitBUA Area | Carpet Area | No. of Rooms | No. of Tenement |
|-------------------------|---------|--------------|--------------|-------------|--------------|-----------------|
| GROUND FLOOR PLAN       | SPLIT A | FLAT         | 136.25       | 136.06      | 6            | 1               |
| TYPICAL -1&2 FLOOR PLAN | SPLIT A | FLAT         | 0.00         | 0.00        | 6            | 0               |
| Total:                  | -       | -            | 136.25       | 136.06      | 18           | 1               |

**FAR & Tenement Details (Table 4c-1)**

| Building      | No. of Same Bldg | Total Built Up Area (Sq.mt.) | Proposed FAR Area (Sq.mt.) Resi. | Total FAR Area (Sq.mt.) | Total Consumed Additional FAR Area (Sq.mt.) | Tnmt (No.) |
|---------------|------------------|------------------------------|----------------------------------|-------------------------|---|------------|
| A (BUILDING)  | 1                | 162.30                       | 162.30                           | 162.30                  | 162.30                                      | 01         |
| Grand Total : | 1                | 162.30                       | 162.30                           | 162.30                  | 162.30                                      | 01         |

**Building USE/SUBUSE Details**

| Building Name | Building Use | Building SubUse                    | Building Structure | Floor Name              | Floor Use   | Floor SubUse                       | FAR Name        | FAR Use     | FAR SubUse                         |
|---------------|--------------|------------------------------------|--------------------|-------------------------|-------------|------------------------------------|-----------------|-------------|------------------------------------|
| A (BUILDING)  | Residential  | Bungalow/ Dwelling / Non Apartment | Non-Highrise       | GROUND FLOOR PLAN       | Residential | Bungalow/ Dwelling / Non Apartment | Residential FAR | Residential | Bungalow/ Dwelling / Non Apartment |
|               |              |                                    |                    | TYPICAL -1&2 FLOOR PLAN | Residential | Bungalow/ Dwelling / Non Apartment | Residential FAR | Residential | Bungalow/ Dwelling / Non Apartment |
|               |              |                                    |                    | TERRACE FLOOR PLAN      | Residential | Bungalow/ Dwelling / Non Apartment | -               | -           | -                                  |

| LTP NAME AND SIGNATURE                  | STRUCTURAL ENG'S NAME AND SIGNATURE | BUILDER NAME AND SIGNATURE | DIGITAL SIGNATURE |
|---|-------------------------------------|----------------------------|-------------------|
| PANKAJ KUMAR SINGH<br>MNNP/ENG/006/2019 |                                     |                            |                   |