

TERRACE FLOOR PLAN (SCALE 1:100)

SITE PLAN

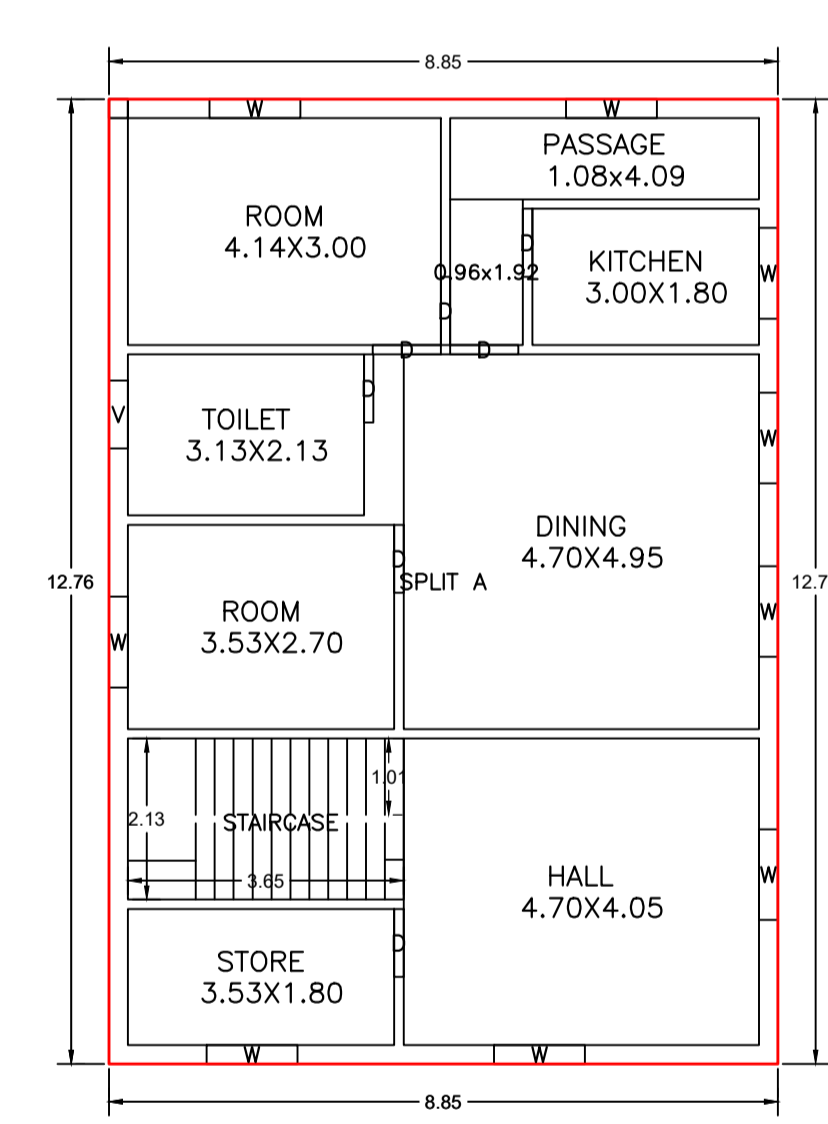

GROUND FLOOR PLAN (Proposed) (SCALE 1:100)

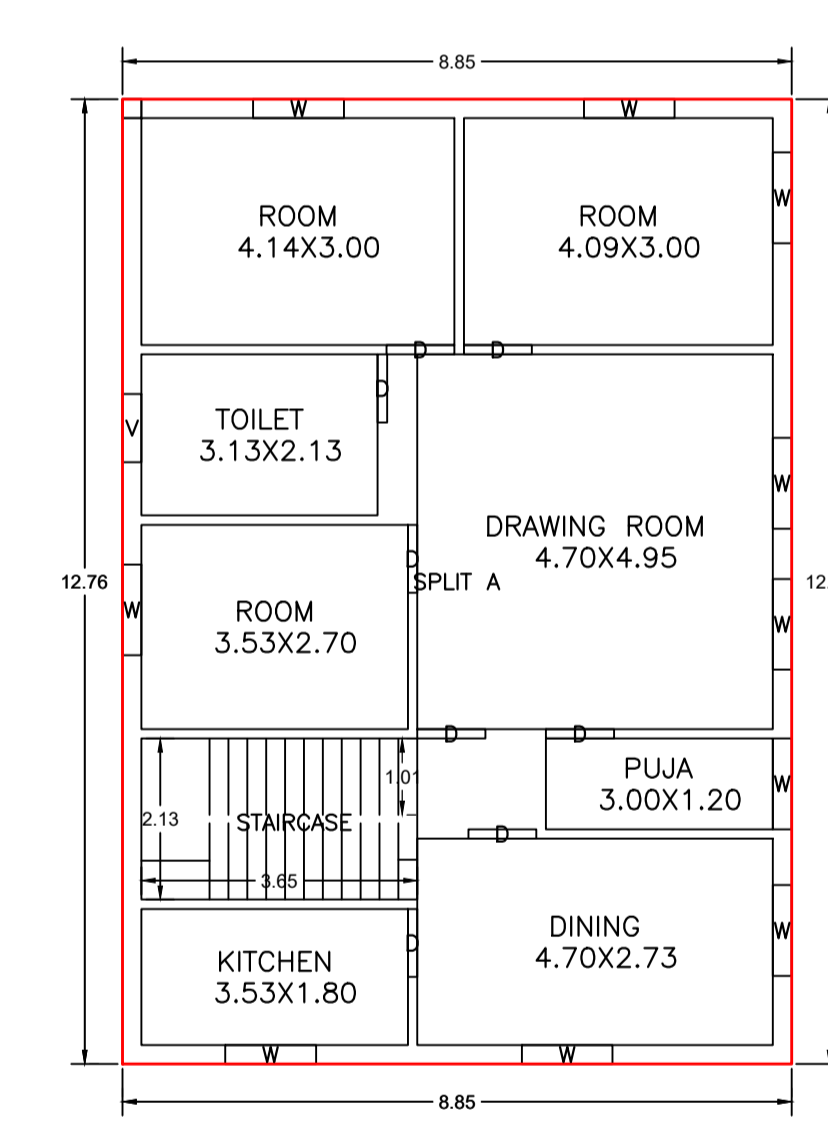

FIRST FLOOR PLAN (Proposed) (SCALE 1:100)

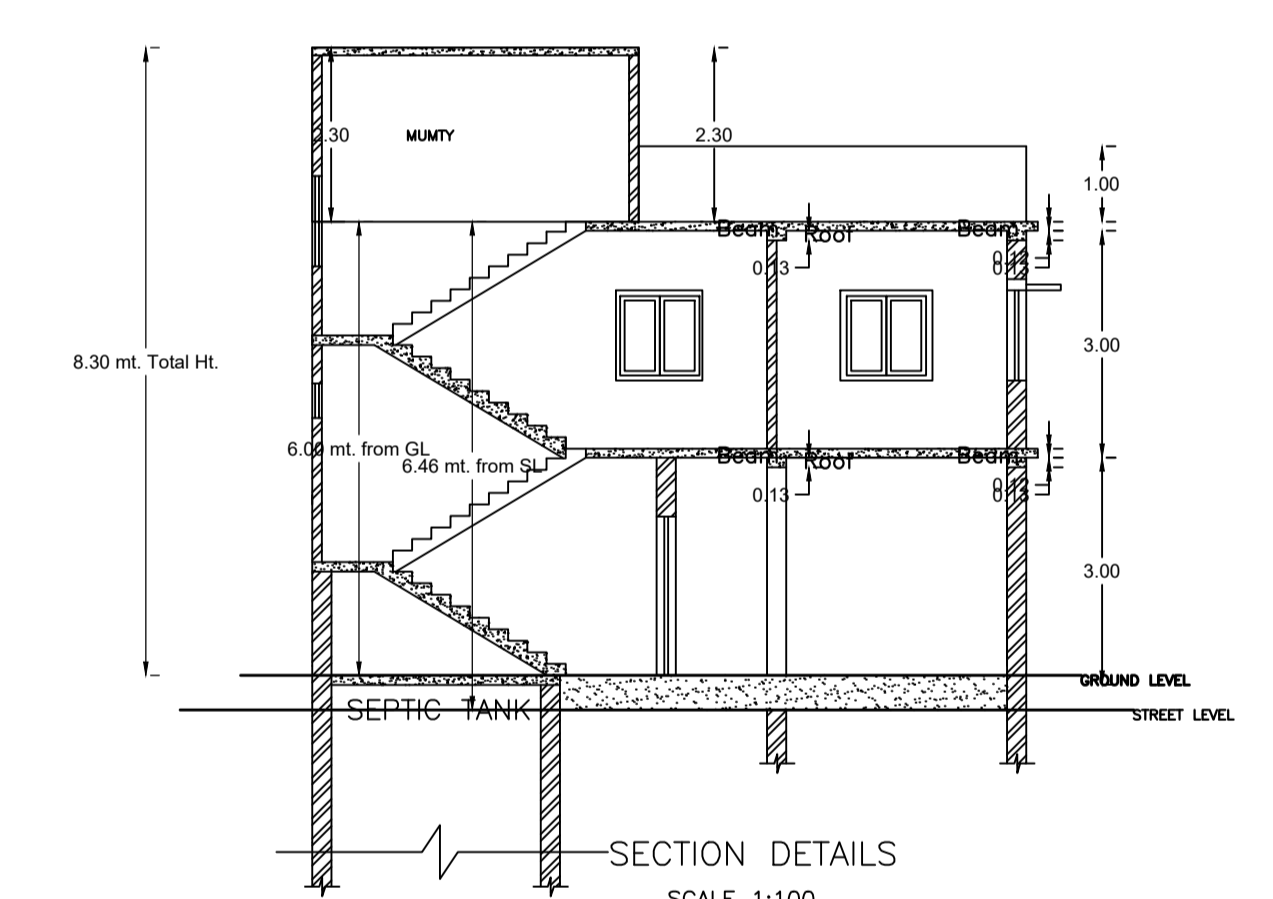

SECTION DETAILS (SCALE 1:100)

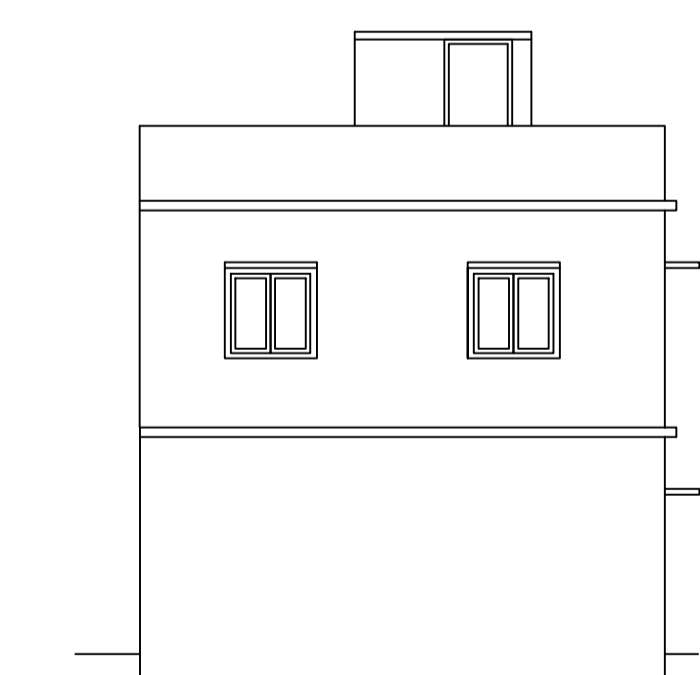

BACK ELEVATION (SCALE 1:100)

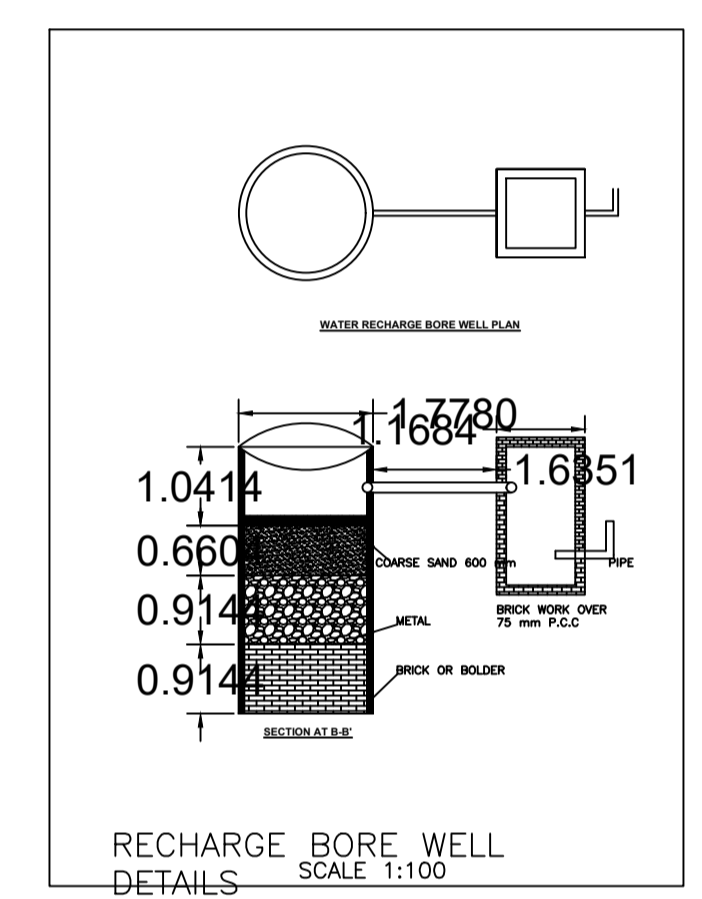

RECHARGE BORE WELL DETAILS (SCALE 1:100)

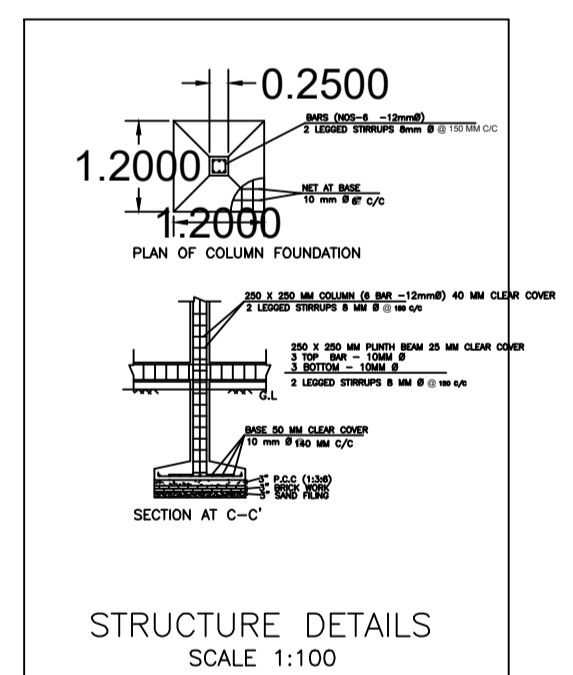

STRUCTURE DETAILS (SCALE 1:100)

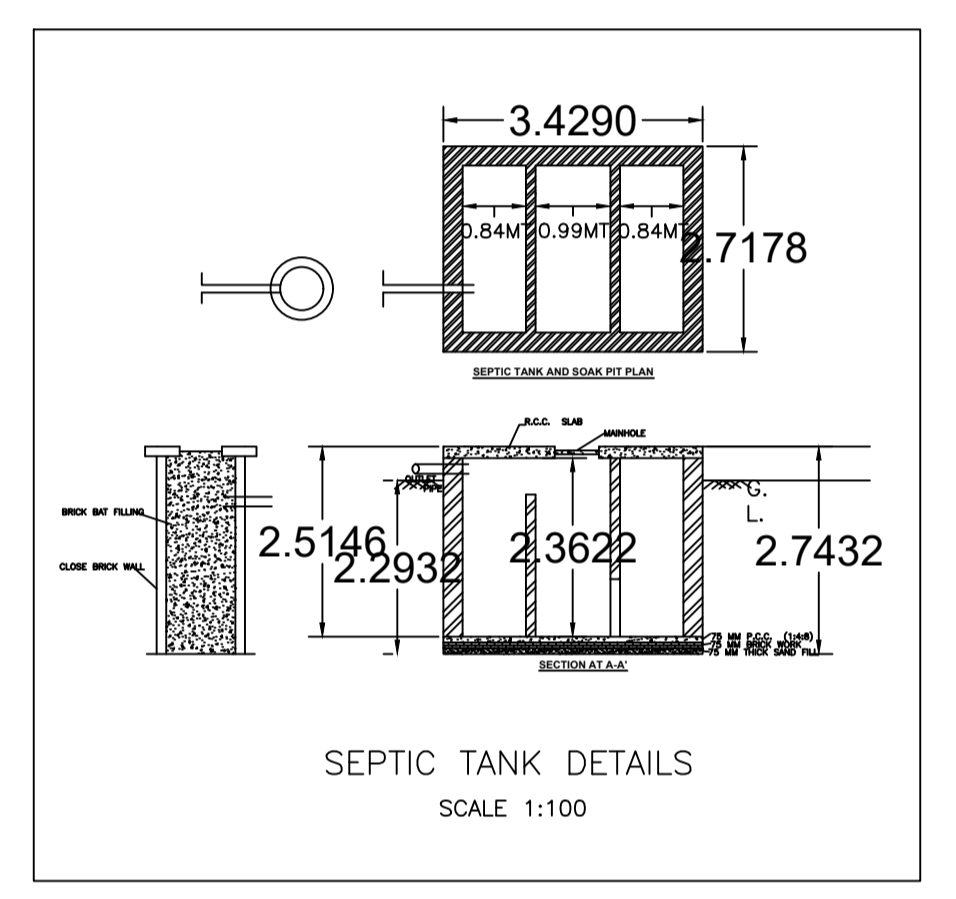

SEPTIC TANK DETAILS (SCALE 1:100)

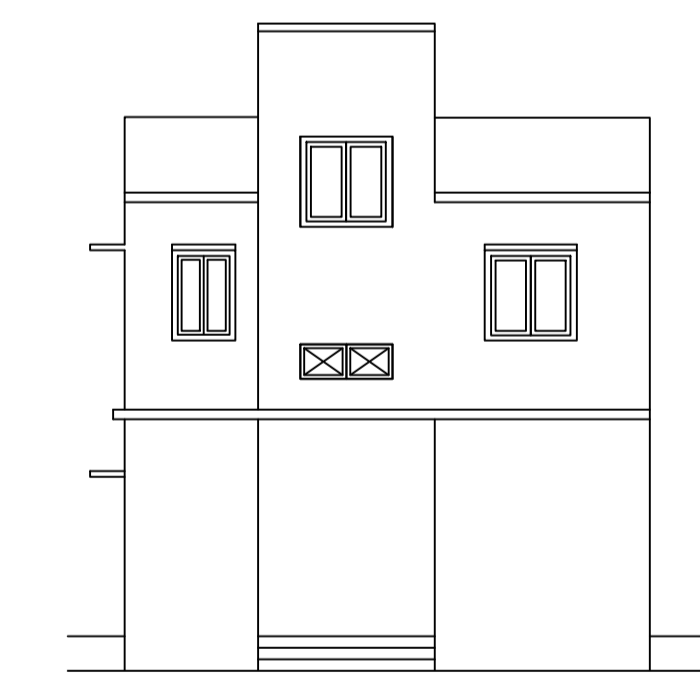

FRONT ELEVATION (SCALE 1:100)

Floor Name	Total Built Up Area (Sq.mt.)	Proposed FAR Area (Sq.mt.)	Total FAR Area (Sq.mt.)	Total Consumed Additional FAR Area (Sq.mt.)	Tnmt (No.)
Ground Floor	112.93	112.93	112.93	112.93	01
First Floor	112.93	112.93	112.93	112.93	00
Terrace Floor	0.00	0.00	0.00	0.00	00
Total :	225.86	225.86	225.86	225.86	01
Total Number of Same Buildings	1				
Total :	225.86	225.86	225.86	225.86	01

SCHEDULE OF DOOR:

BUILDING NAME	NAME	LENGTH	HEIGHT	NOS
A (BUILDING)	D	0.90	2.10	15

SCHEDULE OF WINDOW/VENTILATION:

BUILDING NAME	NAME	LENGTH	HEIGHT	NOS
A (BUILDING)	V	0.90	0.60	02
A (BUILDING)	W	1.20	1.20	19

UnitBUA Table for Building :A (BUILDING)

FLOOR	Name	UnitBUA Type	UnitBUA Area	Carpet Area	No. of Rooms	No. of Tenement
GROUND FLOOR PLAN	SPLIT A	FLAT	209.24	209.11	8	1
FIRST FLOOR PLAN	SPLIT A	FLAT	0.00	0.00	8	0
Total:	-	-	209.24	209.11	16	1

Building USE/SUBUSE Details

Building Name	Building Use	Building SubUse	Building Structure	Floor Name	Floor Use	Floor SubUse	FAR Name	FAR Use	FAR SubUse
A (BUILDING)	Residential	Bungalow/ Dwelling / Non Apartment	Non-Highrise	GROUND FLOOR PLAN	Residential	Bungalow/ Dwelling / Non Apartment	Residential FAR	Residential	Bungalow/ Dwelling / Non Apartment
				FIRST FLOOR PLAN	Residential	Bungalow/ Dwelling / Non Apartment	Residential FAR	Residential	Bungalow/ Dwelling / Non Apartment
				TERRACE FLOOR PLAN	Residential	Bungalow/ Dwelling / Non Apartment	-	-	-

Proposal Basic Information

Proposal File No.	MNNP/BJ/0253/W03/2024
Owner Name	BINAY KUMAR PANDEY
Khata No	18
Plot No	282
Village Name	Nimiya
Use	Residential
SubUse	Bungalow/ Dwelling / Non Apartment

AREA STATEMENT

AREA DETAILS:	AREA OF PLOT (Minimum)	SQ.MT.
AREA OF PLOT (Minimum)	(A)	175.19
Deduction for NetPlot Area		
Surrender Free of Cost		11.90
NET AREA OF PLOT (Gross Plot Area - Deduction from Gross Plot area)	(A-Deductions)	163.30
Deduction for Balance Plot Area (from Gross Plot Area)		
Surrender Free of Cost		11.90
Common Plot		14.71
Total		26.61
BALANCE AREA OF PLOT (Net Plot Area - Recreational/Amenity space)	(A-Deductions)	148.58
PLOT AREA FOR COVERAGE (Net Plot Area)	(A-Deductions)	163.30
Plot Area for FAR (Net Plot Area + Road Widening Area)	(A-Deductions)	175.19
COVERAGE CHECK		
Permissible Coverage area (70.00 %)		114.30
Proposed Coverage Area (69.16 %)		112.93
Total Prop. Coverage Area (69.16 %)		112.93
Balance coverage area (0.84 %)		1.37
FAR CHECK		
Perm. FAR Area (1.500)		262.79
Total Perm. FAR area		262.79
Residential FAR		225.86
Proposed FAR Area		225.86
Total Proposed FAR Area		225.86
Consumed FAR (Factor)		1.29
Balance FAR Area		36.94
BUILT UP AREA CHECK		
Total Proposed BuiltUp Area		225.86
ARCHITECT (Regd)		BHOLA SHANKAR PANDEY
ENGINEER (Regd)		
SUPERVISOR (Regd)		
OWNER (Regd)		BINAY KUMAR PANDEY
DEVELOPMENT AUTHORITY		LOCAL BODY

COLOR INDEX

PLOT BOUNDARY	Black
ABUTTING ROAD	Green
PROPOSED CONSTRUCTION	Red
COMMON PLOT	Yellow
ROAD WIDENING AREA	Blue
EXISTING (To be retained)	Orange
EXISTING (To be demolished)	Grey

Buildingwise Floor FAR Details

Floor Name	Building Name A (BUILDING)		Total	
	Proposed Built Up Area (Sq.mt.)	Proposed FAR Area (Sq.mt.)	Total Proposed Built Up Area (Sq.mt.)	Total FAR Area (Sq.mt.)
Ground Floor	112.93	112.93	112.93	112.93
First Floor	112.93	112.93	112.93	112.93
Terrace Floor	0.00	0.00	0.00	0.00
Total :	225.86	225.86	225.86	225.86

FAR & Tenement Details (Table 4c-1)

Building	No. of Same Bldg	Total Built Up Area (Sq.mt.)	Proposed FAR Area (Sq.mt.)	Total FAR Area (Sq.mt.)	Total Consumed Additional FAR Area (Sq.mt.)	Tnmt (No.)
A (BUILDING)	1	225.86	225.86	225.86	225.86	01
Grand Total :	1	225.86	225.86	225.86	225.86	01

LTP NAME AND SIGNATURE BHOLA SHANKAR PANDEY MNNP/ENG/0008/2022	STRUCTURAL ENG'S NAME AND SIGNATURE	BUILDER NAME AND SIGNATURE	DIGITAL SIGNATURE
--	-------------------------------------	----------------------------	-------------------