

Proposal Basic Information

Proposal File No.	MNNP/BP/0237/W02/2024
Owner Name	GIRJAMANI DEVI
Khata No	40
Plot No	44
Village Name	Sudna
Use	Residential
SubUse	Bungalow/ Dwelling / Non Apartment

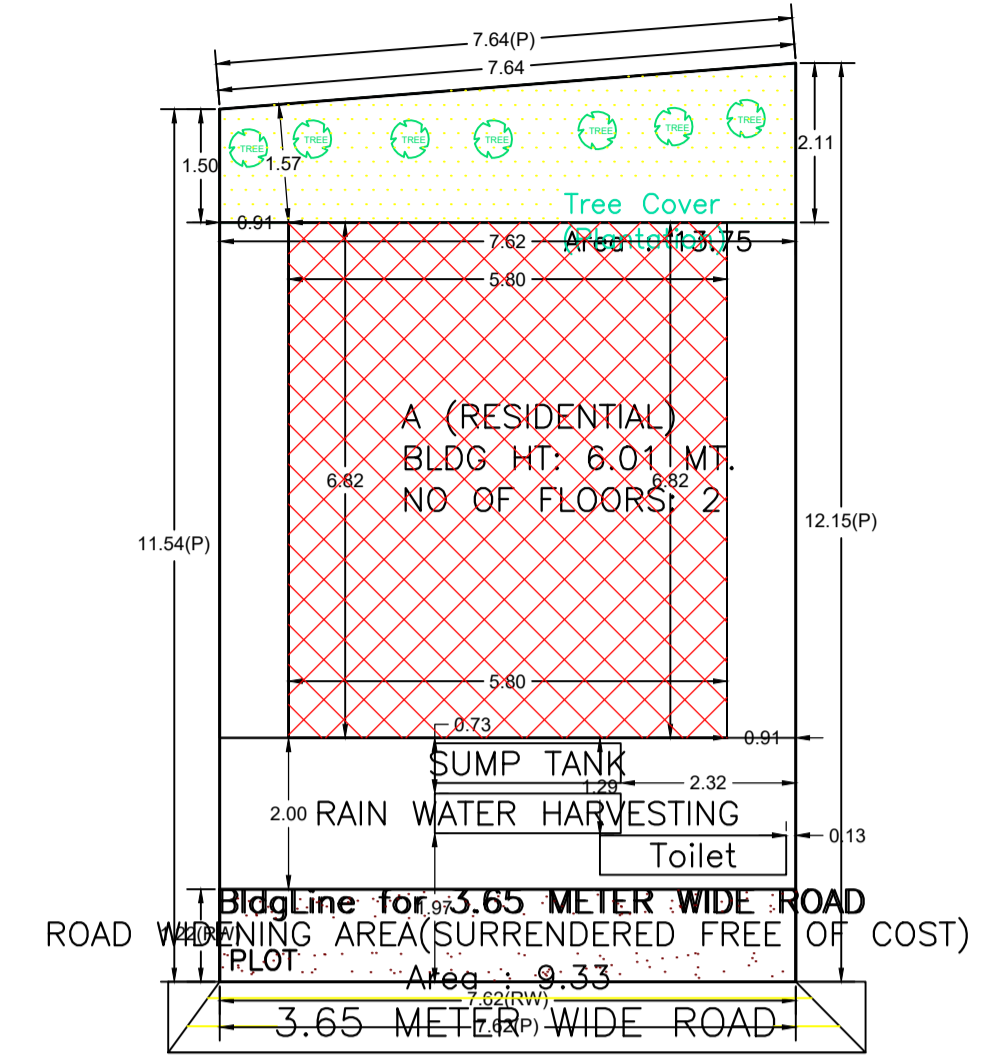

SITE PLAN

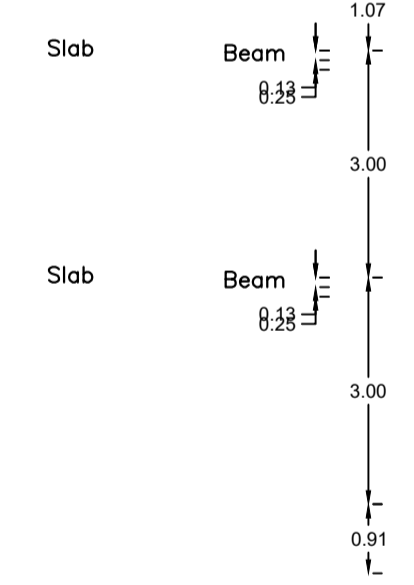
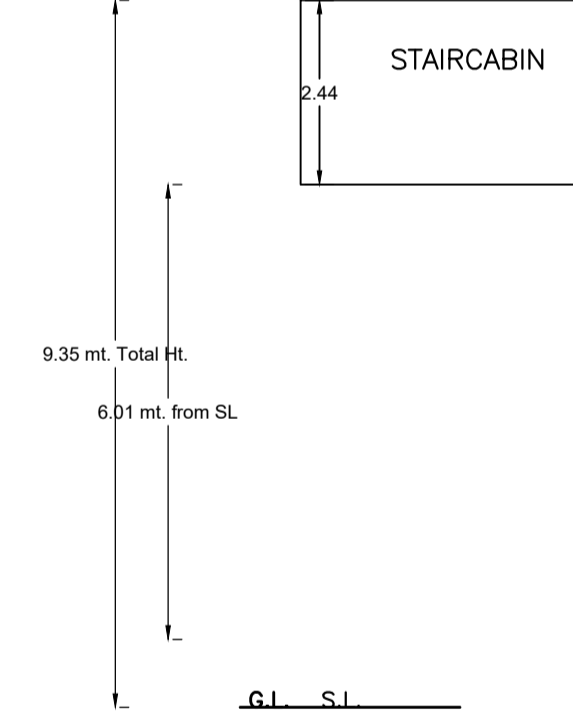
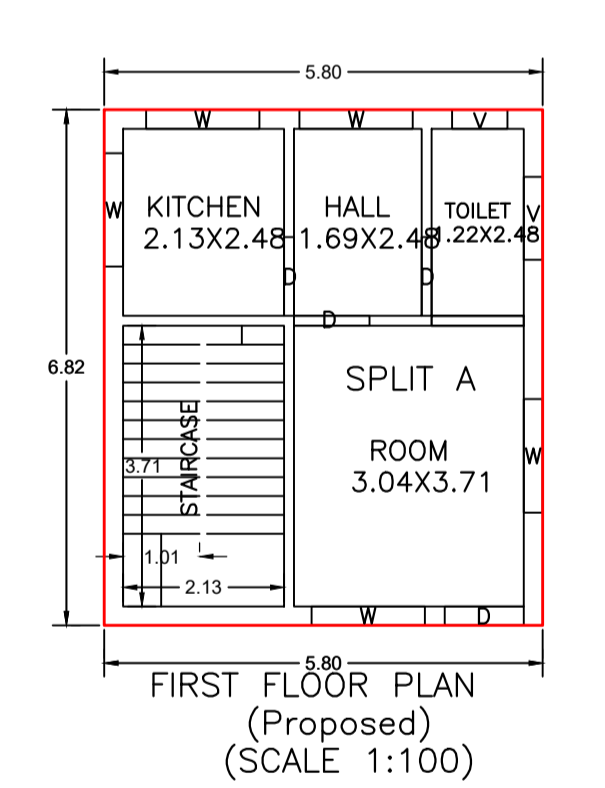
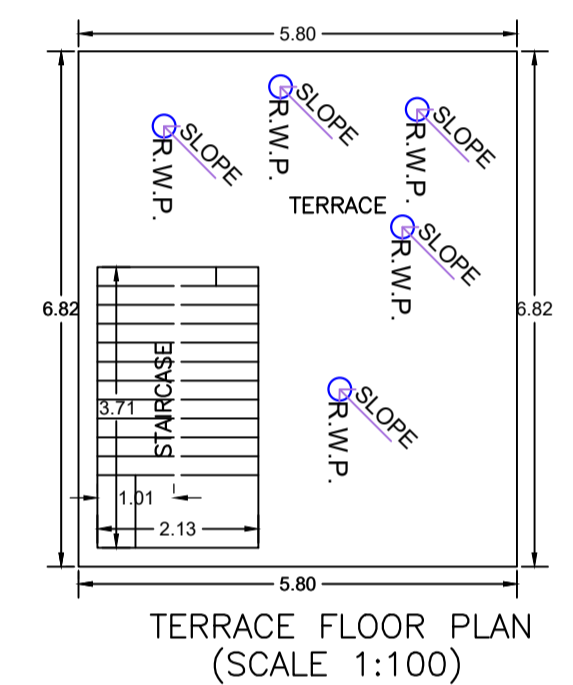
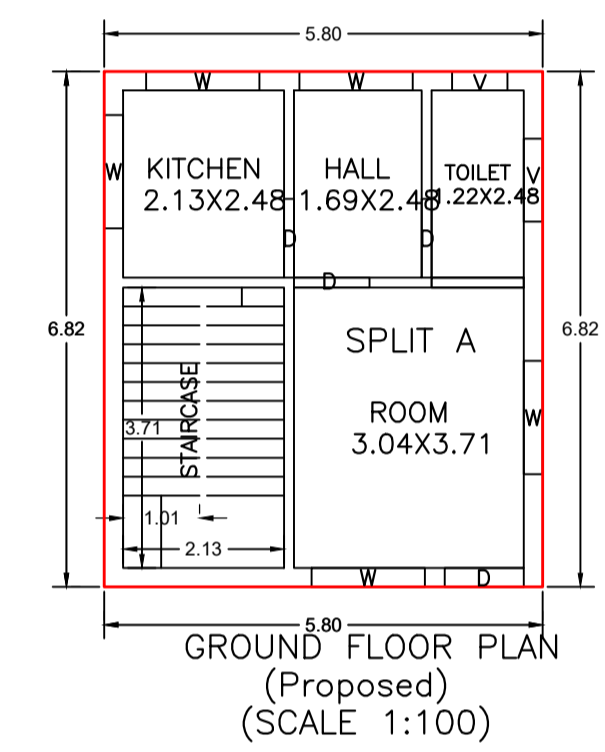

Building USE/SUBUSE Details

Building Name	Building Use	Building SubUse	Building Structure	Floor Name	Floor Use	Floor SubUse	FAR Name	FAR Use	FAR SubUse
A (RESIDENTIAL)	Residential	Bungalow/ Dwelling / Non Apartment	Non-Highrise	GROUND FLOOR PLAN	Residential	Bungalow/ Dwelling / Non Apartment	Residential FAR	Residential	Bungalow/ Dwelling / Non Apartment
				FIRST FLOOR PLAN	Residential	Bungalow/ Dwelling / Non Apartment	Residential FAR	Residential	Bungalow/ Dwelling / Non Apartment
				TERRACE FLOOR PLAN	Residential	Bungalow/ Dwelling / Non Apartment	-	-	-

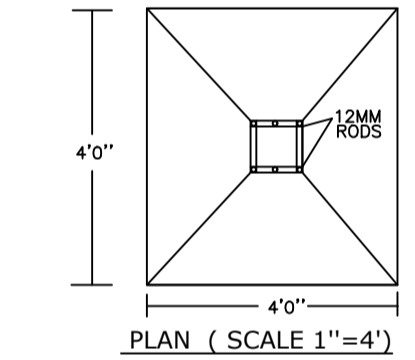
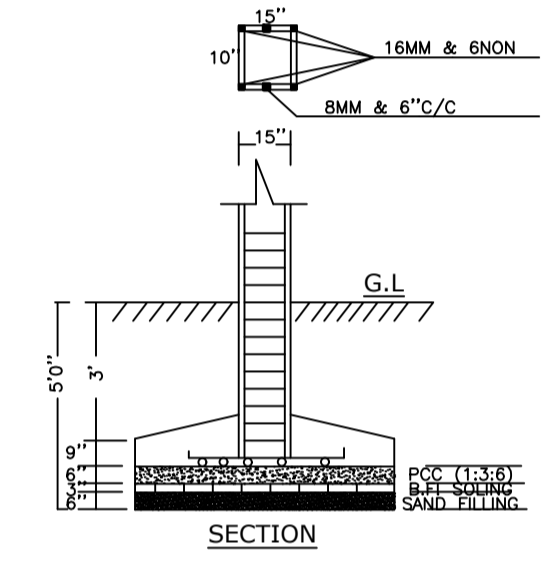
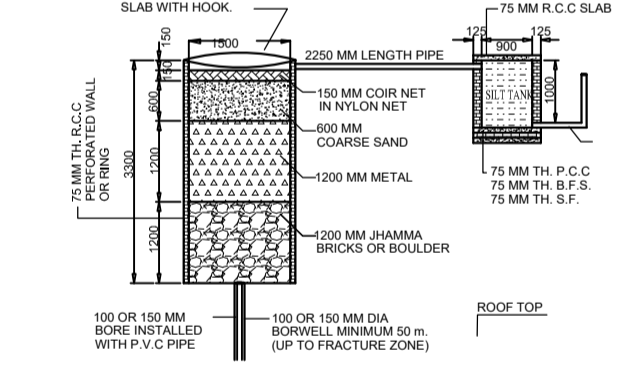
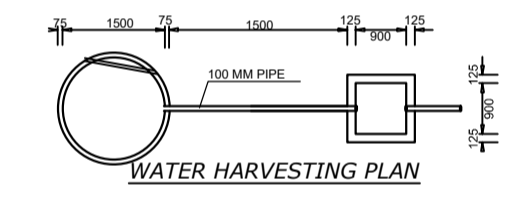
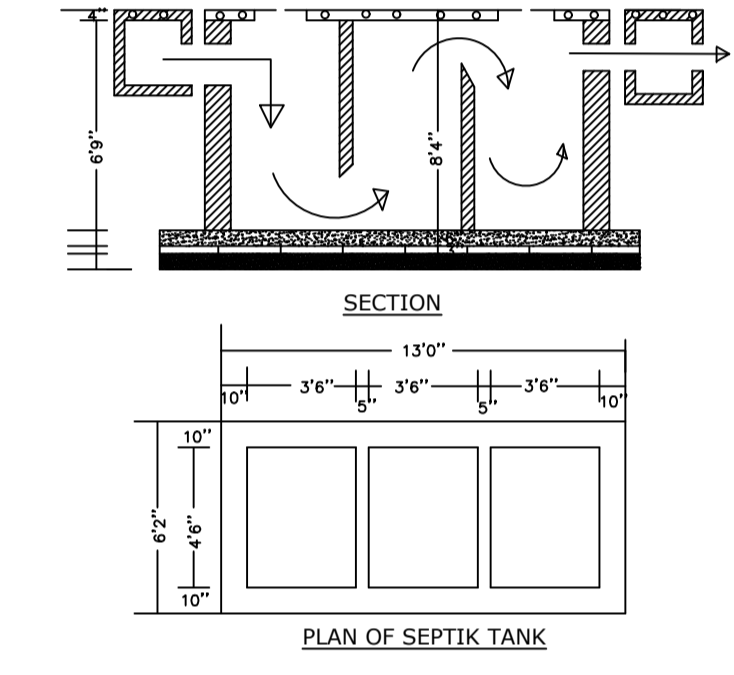

AREA STATEMENT		VERSION NO. : 1.0.74
MEDININAGAR MUNICIPAL CORPORATION		VERSION DATE: 16/10/2020
PROJECT DETAIL:		
Region: JHARKHAND URBAN LOCAL BODIES	Plot Use: Residential	
District: PALAMU	Plot SubUse: Bungalow/ Dwelling / Non Apartment	
Authority: MEDININAGAR MUNICIPAL CORPORATION	PlotNearby/ReligiousStructure: NA	
Inward No: MNNP/BP/0237/W02/2024	Plot/SubPlot No: 44	
Application Type: General Proposal	North: -	
Project Type: Building Permission	South: -	
Nature of Development: New	East: -	
Location of Development Area: New Area	West: -	
AREA DETAILS:		SQ.MT.
AREA OF PLOT (Minimum)	(A)	90.27
Deduction for NetPlot Area		
Surrender Free of Cost		9.33
Total		9.33
NET AREA OF PLOT(Gross Plot Area - Deduction from Gross Plot area)	(A-Deductions)	80.94
Deduction for Balance Plot Area(from Gross Plot Area)		
Surrender Free of Cost		9.33
Common Plot		13.75
Total		23.09
BALANCE AREA OF PLOT(Net Plot Area - Recreational/Amenity space)	(A-Deductions)	67.18
PLOT AREA FOR COVERAGE(Net Plot Area)	(A-Deductions)	80.94
Plot Area for FAR (Net Plot Area + Road/Widening Area)	(A-Deductions)	90.27
COVERAGE CHECK		
Permissible Coverage area (70.00 %)		56.66
Proposed Coverage Area (48.85 %)		39.54
Total Prop. Coverage Area (48.85 %)		39.54
Balance coverage area (21.15 %)		17.12
FAR CHECK		
Perm. FAR Area (1.500)		135.40
Total Perm. FAR area		135.40
Residential FAR		79.07
Proposed FAR Area		79.07
Total Proposed FAR Area		79.07
Consumed FAR (Factor)		0.88
Balance FAR Area		56.33
BUILT UP AREA CHECK		
Total Proposed BuiltUp Area		79.08
ARCHITECT (Regd)	Umesh Prasad	
ENGINEER (Regd)		
SUPERVISOR (Regd)		
OWNER (Regd)	GIRJAMANI DEVI	
DEVELOPMENT AUTHORITY		LOCAL BODY

COLOR INDEX	
PLOT BOUNDARY	Black
ABUTTING ROAD	Green
PROPOSED CONSTRUCTION	Red
COMMON PLOT	Yellow
ROAD WIDENING AREA	Blue
EXISTING (To be retained)	Orange
EXISTING (To be demolished)	White

Building :A (RESIDENTIAL)

Floor Name	Total Built Up Area (Sq.mt.)	Proposed FAR Area (Sq.mt.) Resi.	Total FAR Area (Sq.mt.)	Total Consumed Additional FAR Area (Sq.mt.)	Tnmt (No.)
Ground Floor	39.54	39.54	39.54	39.54	01
First Floor	39.54	39.54	39.54	39.54	00
Terrace Floor	0.00	0.00	0.00	0.00	00
Total :	79.08	79.08	79.08	79.08	01
Total Number of Same Buildings	1				
Total :	79.08	79.08	79.08	79.08	01

SCHEDULE OF DOOR:

BUILDING NAME	NAME	LENGTH	HEIGHT	NOS
A (RESIDENTIAL)	D	1.00	2.10	02
A (RESIDENTIAL)	D	1.04	2.10	06

SCHEDULE OF WINDOW/VENTILATION:

BUILDING NAME	NAME	LENGTH	HEIGHT	NOS
A (RESIDENTIAL)	V	0.73	1.20	02
A (RESIDENTIAL)	V	1.10	1.20	02
A (RESIDENTIAL)	W	1.50	1.20	10

UnitBUA Table for Building :A (RESIDENTIAL)

FLOOR	Name	UnitBUA Type	UnitBUA Area	Carpet Area	No. of Rooms	No. of Tenement
GROUND FLOOR PLAN	SPLIT A	FLAT	60.22	59.90	4	1
FIRST FLOOR PLAN	SPLIT A	FLAT	0.00	0.00	4	0
Total:	-	-	60.22	59.90	8	1

Buildingwise Floor FAR Details

Floor Name	Building Name A (RESIDENTIAL)		Total	
	Proposed Built Up Area (Sq.mt.)	Proposed FAR Area (Sq.mt.)	Total Proposed Built Up Area (Sq.mt.)	Total FAR Area (Sq.mt.)
Ground Floor	39.54	39.54	39.54	39.54
First Floor	39.54	39.54	39.54	39.54
Terrace Floor	0.00	0.00	0.00	0.00
Total :	79.08	79.08	79.08	79.08

FAR & Tenement Details

Building	No. of Same Bldg	Total Built Up Area (Sq.mt.)	Proposed FAR Area (Sq.mt.) Resi.	Total FAR Area (Sq.mt.)	Total Consumed Additional FAR Area (Sq.mt.)	Tnmt (No.)
A (RESIDENTIAL)	1	79.08	79.08	79.08	79.08	01
Grand Total :	1	79.08	79.08	79.08	79.08	01

LTP NAME AND SIGNATURE	STRUCTURAL ENG'S NAME AND SIGNATURE	BUILDER NAME AND SIGNATURE	DIGITAL SIGNATURE
Umesh Prasad MNNP/ENG/0002/2024			