

Proposal Basic Information	
Proposal File No.	MNNP/BP/0239/W33/2024
Owner Name	RENU DEVI
Khata No	355
Plot No	1215/1805
Village Name	Chainpur
Use	Residential
SubUse	Bungalow/ Dwelling / Non Apartment

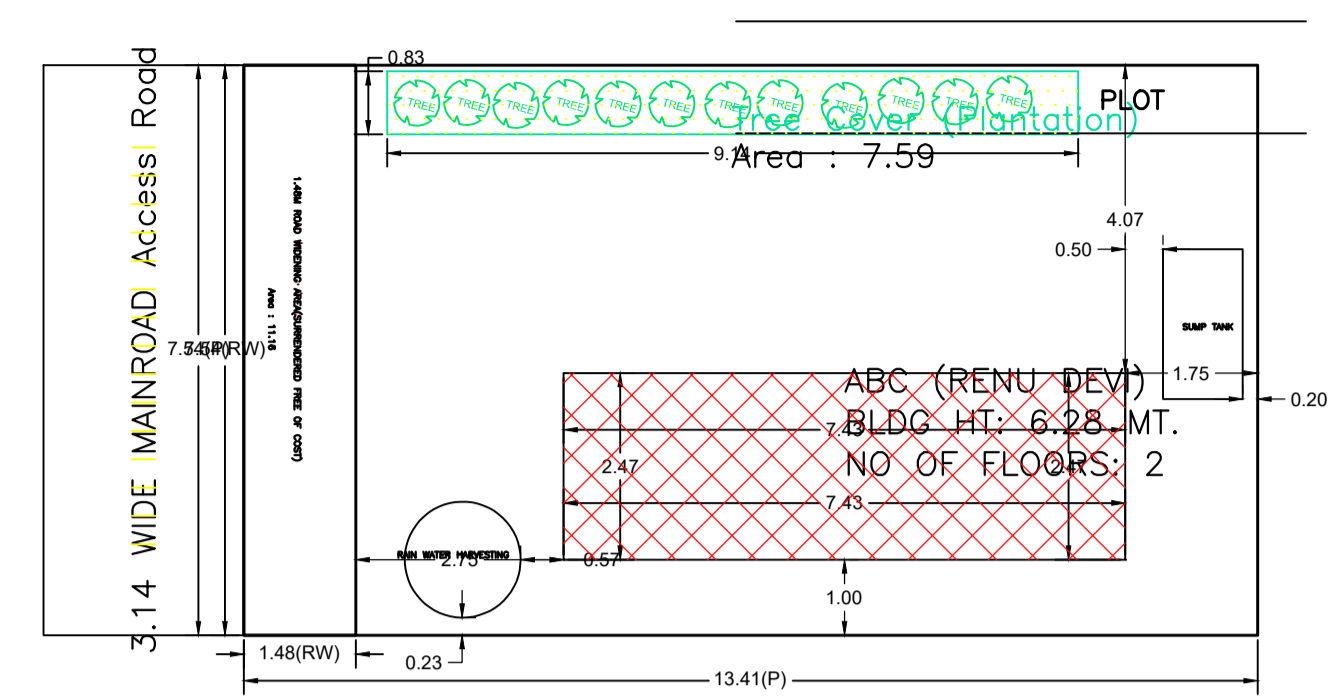
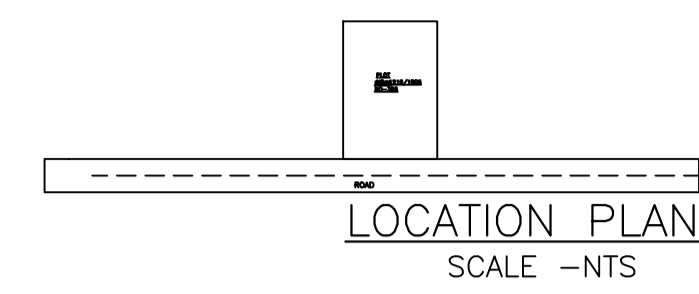

Building USE/SUBUSE Details

Building Name	Building Use	Building SubUse	Building Structure	Floor Name	Floor Use	Floor SubUse	FAR Name	FAR Use	FAR SubUse
ABC (RENU DEVI)	Residential	Bungalow/ Dwelling / Non Apartment	Non-Highrise	GROUND FLOOR PLAN	Residential	Bungalow/ Dwelling / Non Apartment	Residential FAR	Residential	Bungalow/ Dwelling / Non Apartment
				FIRST FLOOR PLAN	Residential	Bungalow/ Dwelling / Non Apartment	Residential FAR	Residential	Bungalow/ Dwelling / Non Apartment
				TERRACE FLOOR PLAN	Residential	Bungalow/ Dwelling / Non Apartment	-	-	-

AREA STATEMENT		VERSION NO. : 1.0.73
MEDINAGAR MUNICIPAL CORPORATION		VERSION DATE: 16/10/2020
PROJECT DETAIL:		
Region: JHARKHAND URBAN LOCAL BODIES	Plot Use: Residential	
District: PALAMU	Plot SubUse: Bungalow/ Dwelling / Non Apartment	
Authority: MEDINAGAR MUNICIPAL CORPORATION	Plot/Nearby/Religious Structure: NA	
Inward No: MNNP/BP/0239/W33/2024	Plot/SubPlot No: 1215/1805	
Application Type: General Proposal	North: Road Width - 10 feet wide road	
Project Type: Building Permission	South: Plot No. - NEEJ VIKRETA	
Nature of Development: New	East: Plot No. - pramod chandavanshi	
Location of Development Area: Old Area	West: Plot No. - NEEJ VIKRETA	
AREA DETAILS:		
AREA OF PLOT (Minimum)	(A)	SQ.MT. 101.11
Deduction for NetPlot Area		
Surrender Free of Cost		11.16
Total		11.16
NET AREA OF PLOT(Gross Plot Area - Deduction from Gross Plot area)	(A-Deductions)	89.95
Deduction for Balance Plot Area(from Gross Plot Area)		
Surrender Free of Cost		11.16
Common Plot		7.59
Total		18.75
BALANCE AREA OF PLOT(Net Plot Area - Recreational/Amenity space)	(A-Deductions)	82.36
PLOT AREA FOR COVERAGE(Net Plot Area)	(A-Deductions)	89.95
Plot Area for FAR (Net Plot Area + Road Widening Area)	(A-Deductions)	101.11
COVERAGE CHECK		
Permissible Coverage area (70.00 %)		62.96
Proposed Coverage Area (20.39 %)		18.34
Total Prop. Coverage Area (20.39 %)		18.34
Balance coverage area (49.60 %)		44.62
FAR CHECK		
Perm. FAR Area (1.200)		121.33
Total Perm. FAR area		121.33
Residential FAR		59.50
Proposed FAR Area		59.50
Total Proposed FAR Area		59.50
Consumed FAR (Factor)		0.59
Balance FAR Area		61.63
BUILT UP AREA CHECK		
Total Proposed BuiltUp Area		59.50
ARCHITECT (Regd)		MANORANJAN KUMAR SINGH
ENGINEER (Regd)		
SUPERVISOR (Regd)		
OWNER (Regd)		RENU DEVI
DEVELOPMENT AUTHORITY		LOCAL BODY

SITE PLAN

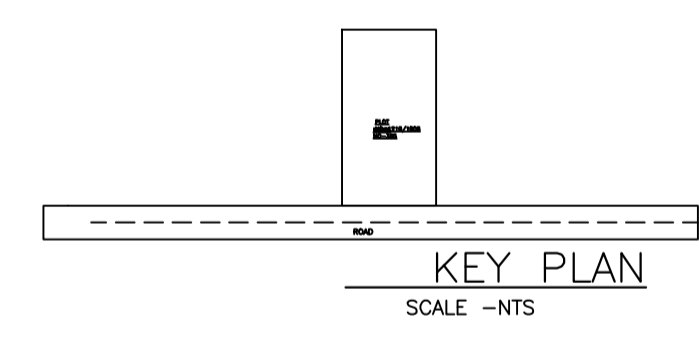
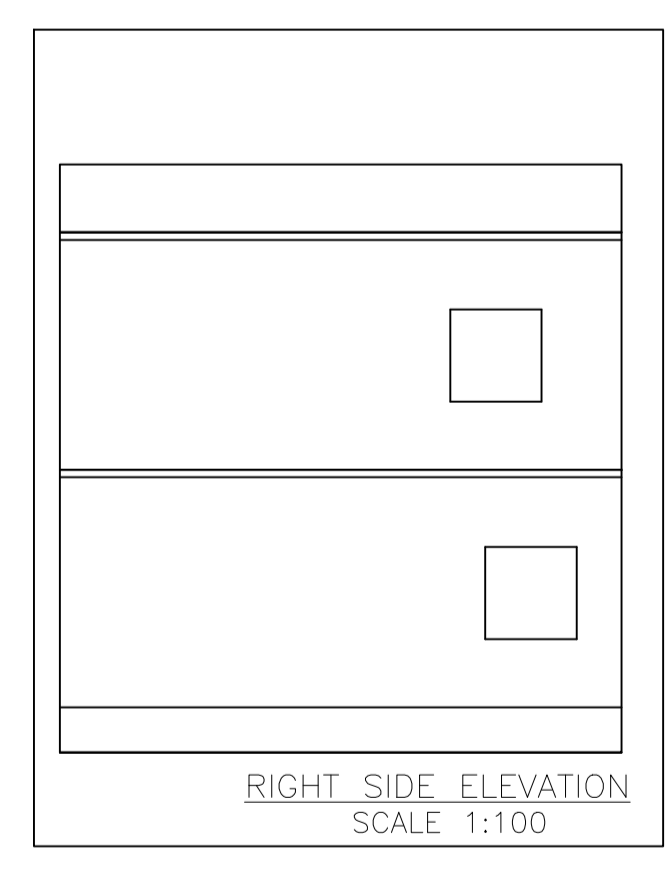
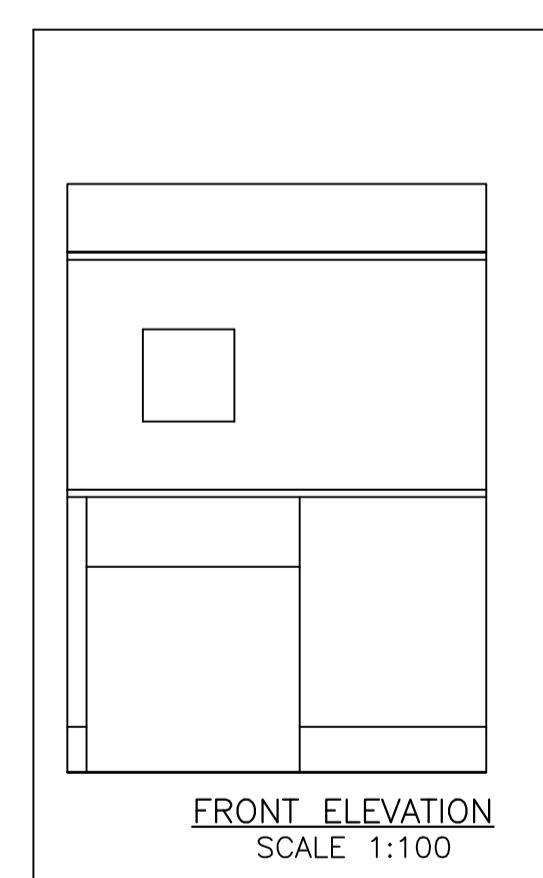
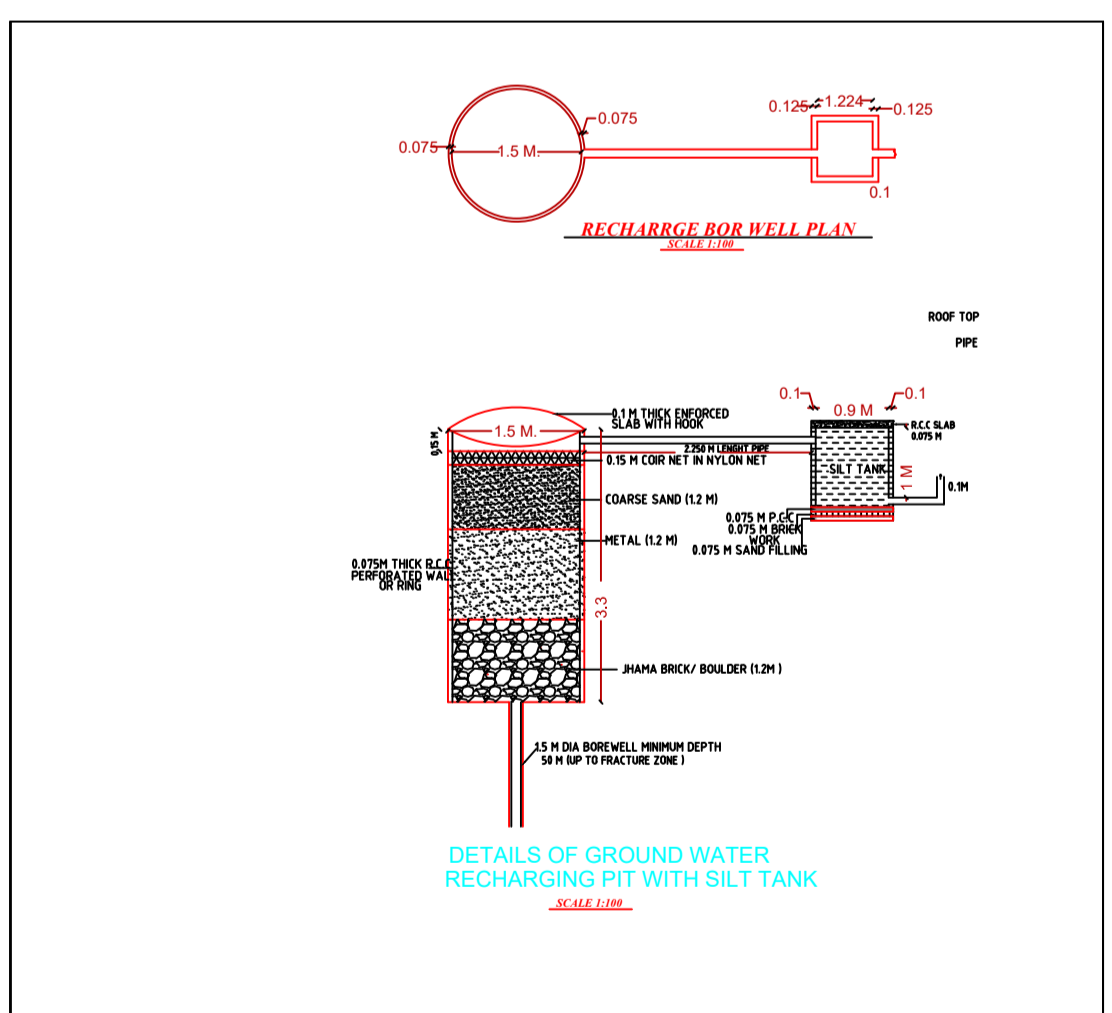
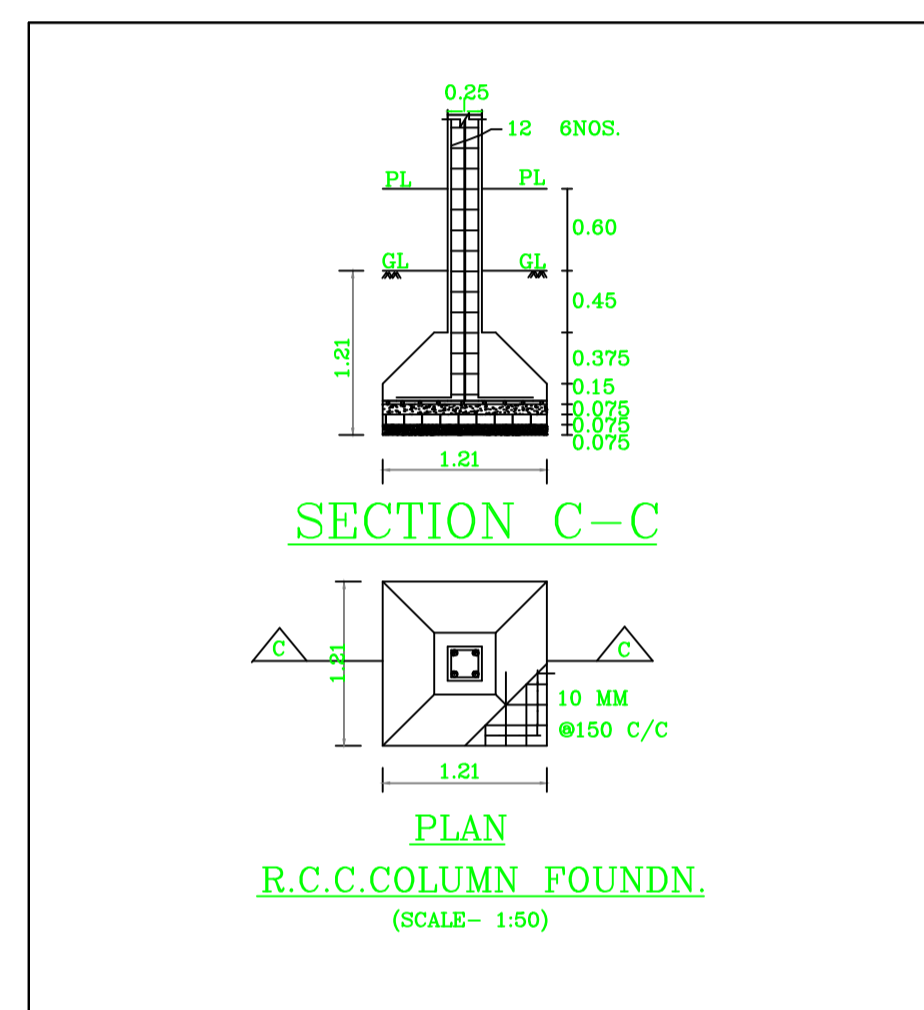
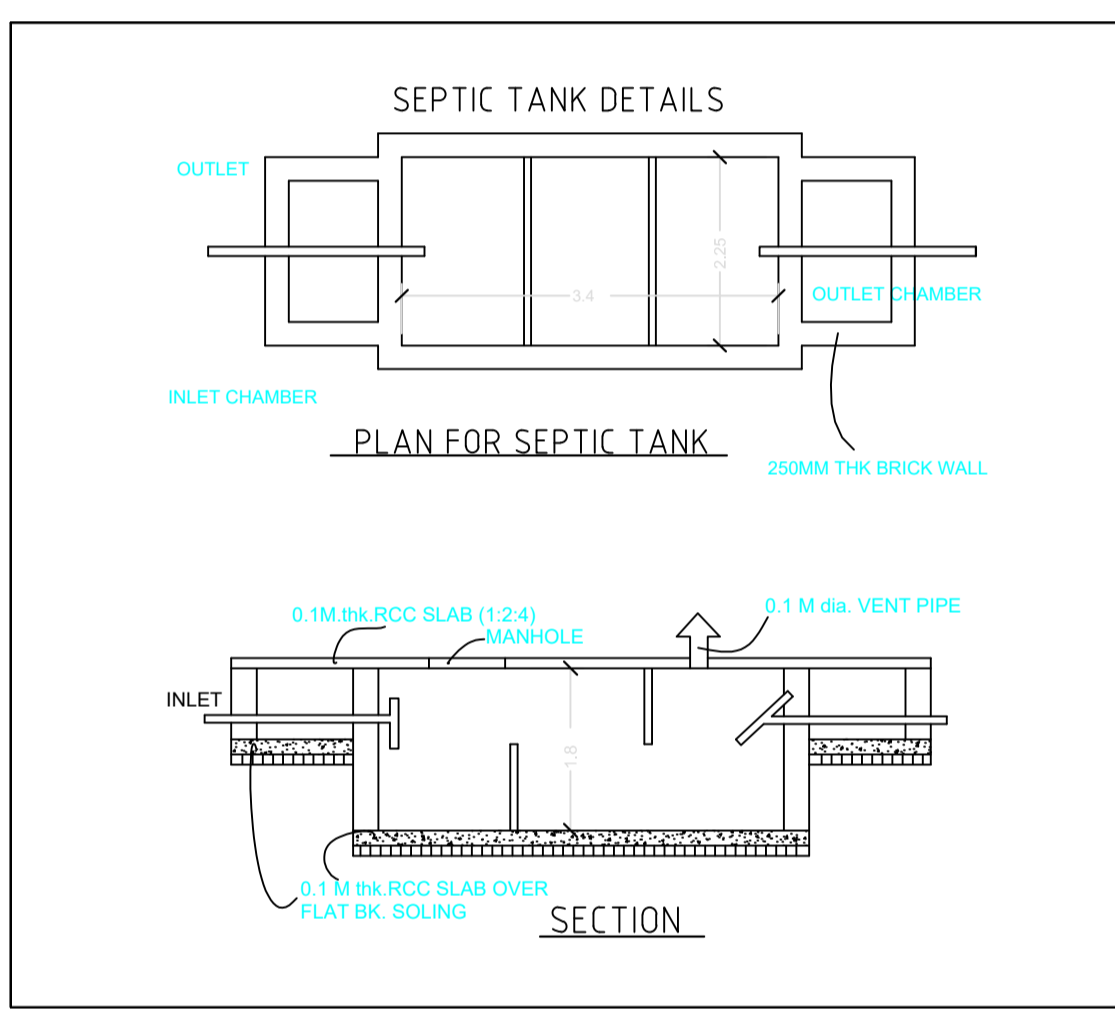
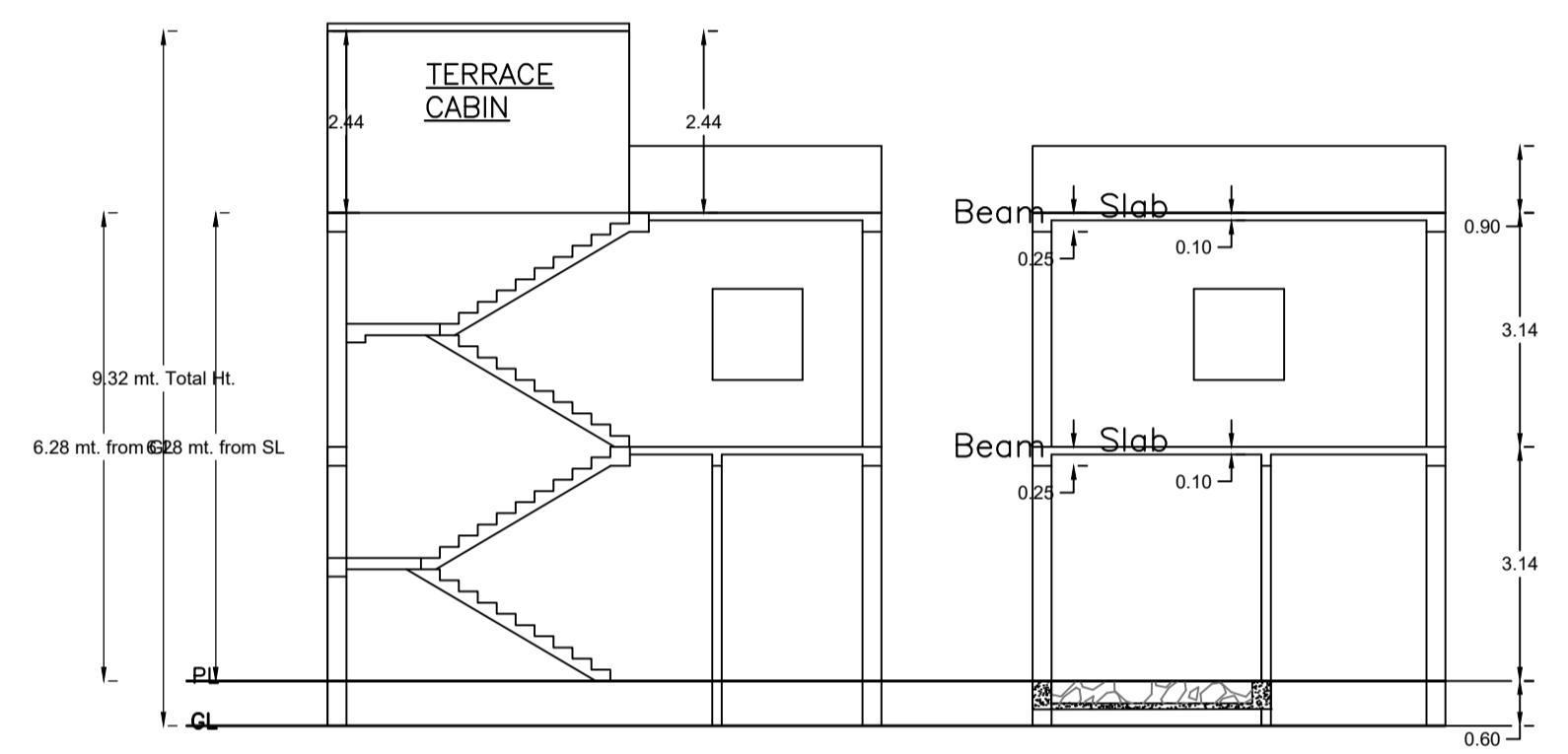
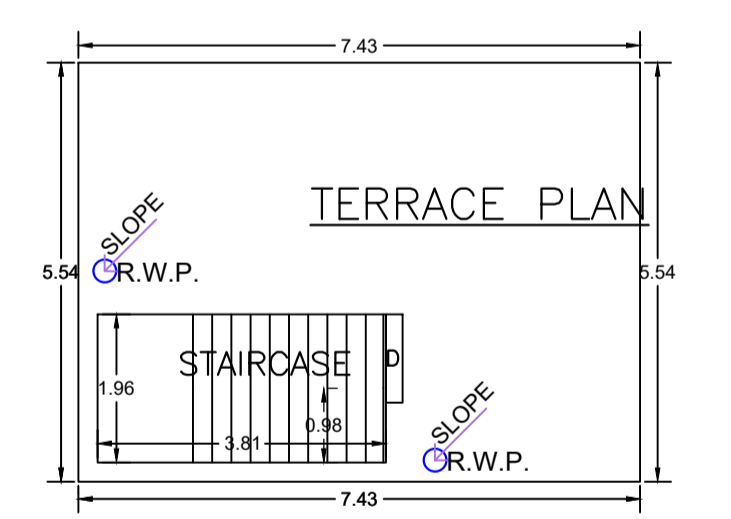
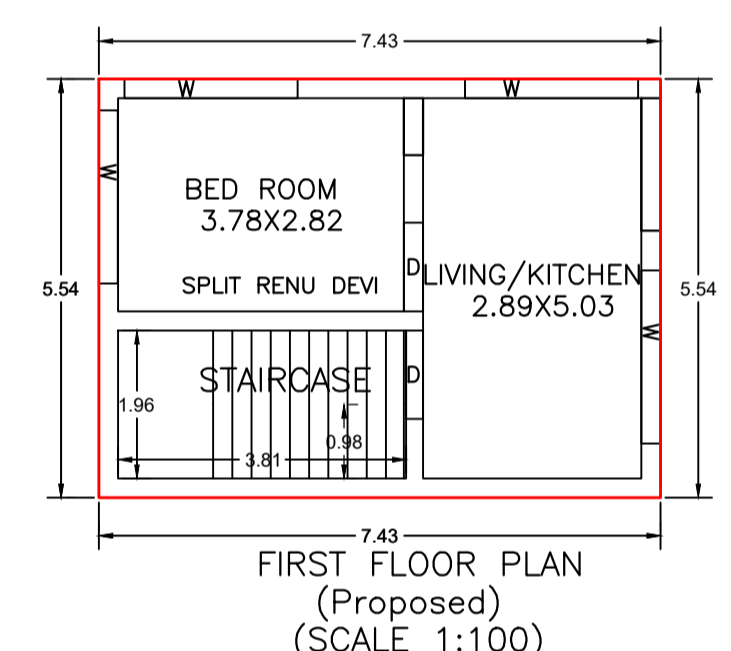
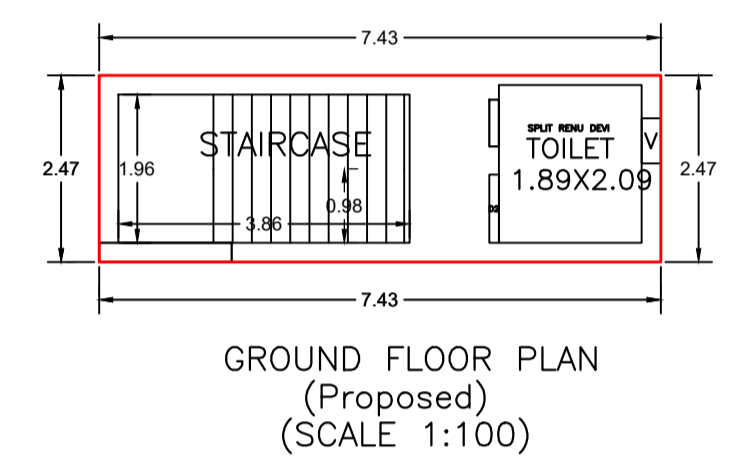

COLOR INDEX	
PLOT BOUNDARY	Black
ABUTTING ROAD	Red
PROPOSED CONSTRUCTION	Green
COMMON PLOT	Yellow
ROAD WIDENING AREA	Blue
EXISTING (To be retained)	Orange
EXISTING (To be demolished)	Light Blue

Building :ABC (RENU DEVI)

Floor Name	Total Built Up Area (Sq.mt.)	Proposed FAR Area (Sq.mt.)	Total FAR Area (Sq.mt.)	Total Consumed Additional FAR Area (Sq.mt.)	Tnmt (No.)
Ground Floor	18.34	18.34	18.34	18.34	01
First Floor	41.16	41.16	41.16	41.16	00
Terrace Floor	0.00	0.00	0.00	0.00	00
Total :	59.50	59.50	59.50	59.50	01
Total Number of Same Buildings :	1				
Total :	59.50	59.50	59.50	59.50	01

SCHEDULE OF DOOR:

BUILDING NAME	NAME	LENGTH	HEIGHT	NOS
ABC (RENU DEVI)	D2	0.90	2.10	01
ABC (RENU DEVI)	D	1.17	2.10	02

SCHEDULE OF WINDOW/VENTILATION:

BUILDING NAME	NAME	LENGTH	HEIGHT	NOS
ABC (RENU DEVI)	V	0.60	0.60	01
ABC (RENU DEVI)	W	2.29	1.21	04

UnitBUA Table for Building :ABC (RENU DEVI)

FLOOR	Name	UnitBUA Type	UnitBUA Area	Carpet Area	No. of Rooms	No. of Tenement
GROUND FLOOR PLAN	SPLIT RENU DEVI	FLAT	31.92	31.65	1	1
FIRST FLOOR PLAN	SPLIT RENU DEVI	FLAT	0.00	0.00	2	0
Total:	-	-	31.92	31.65	3	1

Buildingwise Floor FAR Details

Floor Name	Building Name		Total	
	Proposed Built Up Area (Sq.mt.)	Proposed FAR Area (Sq.mt.)	Total Proposed Built Up Area (Sq.mt.)	Total FAR Area (Sq.mt.)
Ground Floor	18.34	18.34	18.34	18.34
First Floor	41.16	41.16	41.16	41.16
Terrace Floor	0.00	0.00	0.00	0.00
Total :	59.50	59.50	59.50	59.50

FAR & Tenement Details (Table 4c-1)

Building	No. of Same Bldg	Total Built Up Area (Sq.mt.)	Proposed FAR Area (Sq.mt.)	Total FAR Area (Sq.mt.)	Total Consumed Additional FAR Area (Sq.mt.)	Tnmt (No.)
ABC (RENU DEVI)	1	59.50	59.50	59.50	59.50	01
Grand Total :	1	59.50	59.50	59.50	59.50	01

LTP NAME AND SIGNATURE	STRUCTURAL ENG'S NAME AND SIGNATURE	BUILDER NAME AND SIGNATURE	DIGITAL SIGNATURE
MANORANJAN KUMAR SINGH MNNP/ENG/0003/2024			