

Proposal Basic Information	
Proposal File No.	MNP/IBP/0012/W09/2020
Owner Name	SAYIDA KHATUN
Khata No	30
Plot No	NA
Village Name	Madhupur Khas
Use	Residential
SubUse	Bungalow/ Dwelling / Non Apartment

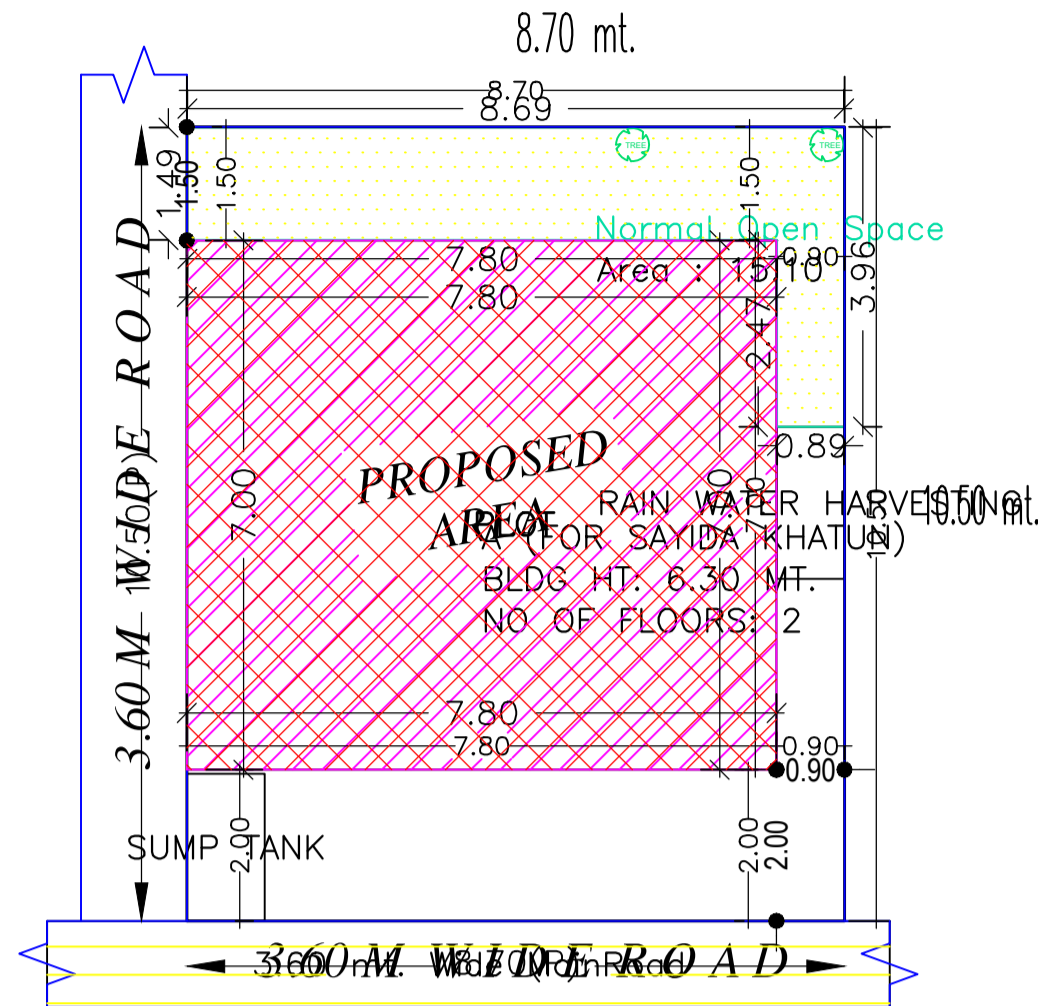

SITE PLAN

AREA STATEMENT		VERSION NO.: 1.0.50
MADHUPUR NAGAR		VERSION DATE: 16/10/2020
PARISHAD		
PROJECT DETAIL:		
Region: JHARKHAND URBAN LOCAL BODIES	Plot Use: Residential	
District: DEOGHAR	Plot SubUse: Bungalow/ Dwelling / Non Apartment	
Authority: MADHUPUR NAGAR PARISHAD	Plot/Nearby/ReligiousStructure: NA	
Inward No: MNP/IBP/0012/W09/2020	Plot/SubPlot No: NA	
Application Type: General Proposal	North: Road Width - 3.60	
Project Type: Building Permission	South: Plot No. - HOUSE OF MD. TAUFIQUE AND MD. NASIM	
Nature of Development: New	East: Plot No. - HOUSE OF MD. FATAH & JAMAL AKHTAR	
Location of Development Area: Old Area	West: Road Width - 3.60	
AREA DETAILS:		
AREA OF PLOT (Minimum)	(A)	SQ.MT. 91.35
NET AREA OF PLOT(Gross Plot Area - Deduction from Gross Plot area)	(A-Deductions)	91.35
Deduction for Balance Plot Area(from Gross Plot Area)		
Common Plot		15.10
Total		15.10
BALANCE AREA OF PLOT(Net Plot Area - Recreational/Amenity space)	(A-Deductions)	76.25
PLOT AREA FOR COVERAGE(Net Plot Area)	(A-Deductions)	91.35
Plot Area for FAR (Net Plot Area + RoadWidening Area)	(A-Deductions)	91.35
COVERAGE CHECK		
Permissible Coverage area (70.00 %)		63.94
Proposed Coverage Area (59.77 %)		54.60
Total Prop. Coverage Area (59.77 %)		54.60
Balance coverage area (10.22 %)		9.34
FAR CHECK		
Perm. FAR Area (1.50)		137.02
Total Perm. FAR area		137.02
Residential FAR		109.20
Proposed FAR Area		109.20
Total Proposed FAR Area		109.20
Consumed FAR (Factor)		1.20
Balance FAR Area		27.82
BUILT UP AREA CHECK		
Total Proposed BuiltUp Area		109.20
ARCHITECT (Regd)	RAJKISHOR KUMAR	
ENGINEER (Regd)		
SUPERVISOR (Regd)		
OWNER (Regd)	SAYIDA KHATUN	
DEVELOPMENT AUTHORITY	LOCAL BODY	

Building USE/SUBUSE Details

Building Name	Building Use	Building SubUse	Building Structure
A (FOR SAYIDA KHATUN)	Residential	Bungalow/ Dwelling / Non Apartment	Non-Highrise

Buildingwise Floor FAR Details

Floor Name	Building Name A (FOR SAYIDA KHATUN)		Total	
	Proposed Built Up Area (Sq.mt.)	Proposed FAR Area (Sq.mt.)	Total Proposed Built Up Area (Sq.mt.)	Total FAR Area (Sq.mt.)
Ground Floor	54.60	54.60	54.60	54.60
First Floor	54.60	54.60	54.60	54.60
Terrace Floor	0.00	0.00	0.00	0.00
Total :	109.20	109.20	109.20	109.20

FAR & Tenement Details (Table 4c-1)

Building	No. of Same Bldg	Total Built Up Area (Sq.mt.)	Proposed FAR Area (Sq.mt.) Resi.	Total FAR Area (Sq.mt.)	Total Consumed Additional FAR Area (Sq.mt.)	Tnmt (No.)
A (FOR SAYIDA KHATUN)	1	109.20	109.20	109.20	109.20	01
Grand Total :	1	109.20	109.20	109.20	109.20	01

COLOR INDEX	
PLOT BOUNDARY	Black
ABUTTING ROAD	Green
PROPOSED CONSTRUCTION	Red
COMMON PLOT	Yellow
ROAD WIDENING AREA	Blue
EXISTING (To be retained)	Light Blue
EXISTING (To be demolished)	Light Yellow

LTP NAME AND SIGNATURE	STRUCTURAL ENG'S NAME AND SIGNATURE	BUILDER NAME AND SIGNATURE	DIGITAL SIGNATURE
RAJKISHOR KUMAR MNP/ENG/0003/2018			

Proposal Basic Information	
Proposal File No.	MNP/IBP/0012/W09/2020
Owner Name	SAYIDA KHATUN
Khata No	30
Plot No	NA
Village Name	Madhupur Khas
Use	Residential
SubUse	Bungalow/ Dwelling / Non Apartment

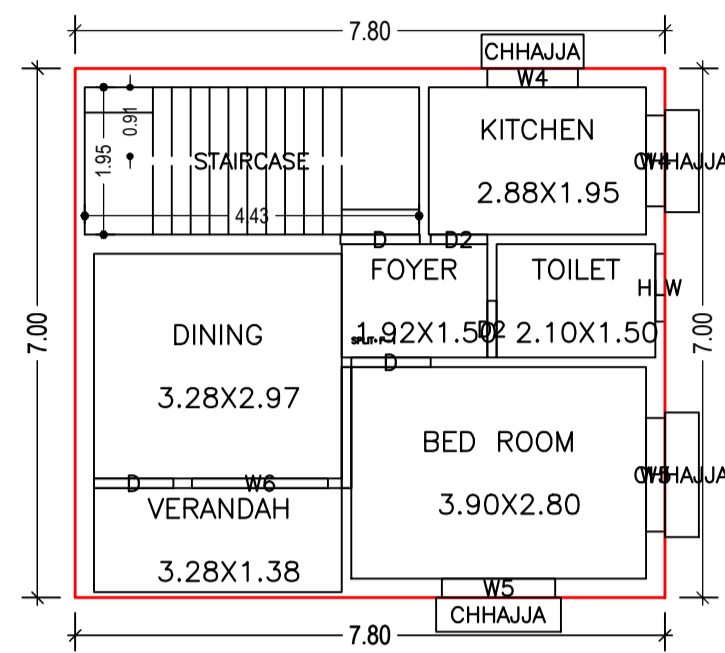

GROUND FLOOR PLAN
(Proposed)
(SCALE 1:100)

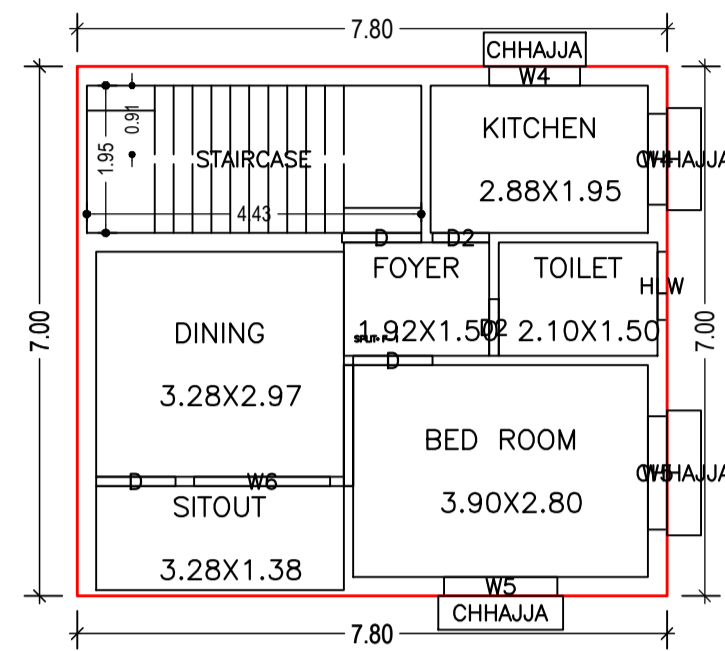

FIRST FLOOR PLAN
(Proposed)
(SCALE 1:100)

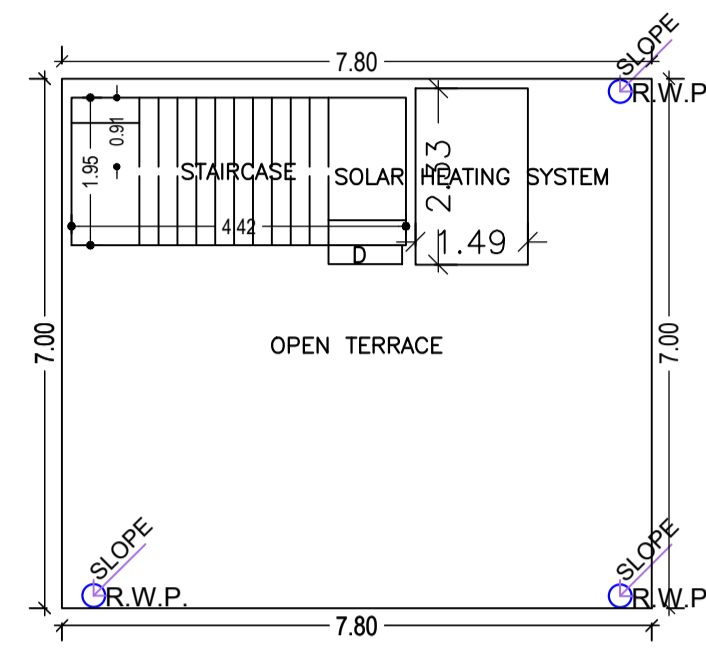

TERRACE FLOOR PLAN
(SCALE 1:100)

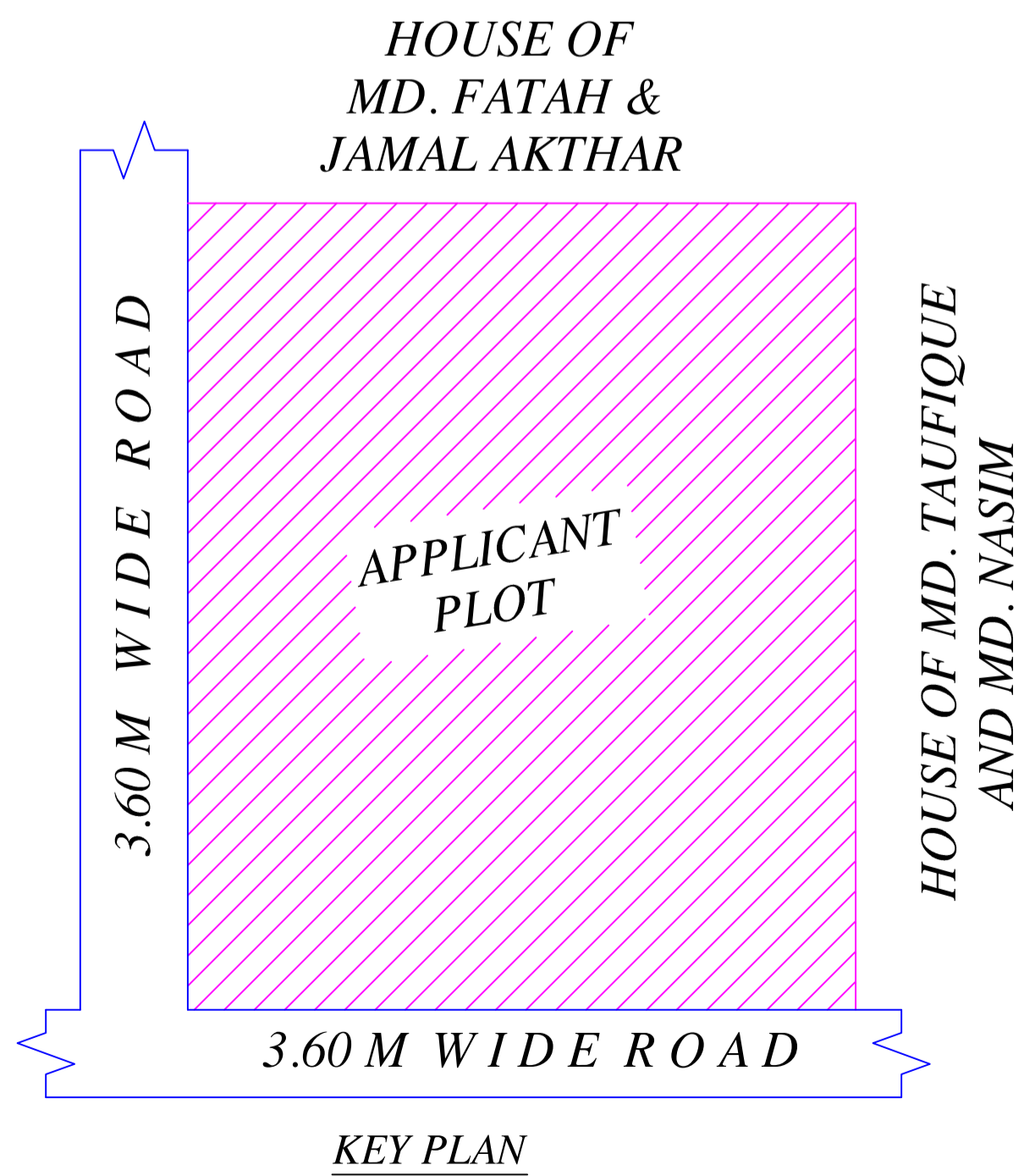

KEY PLAN

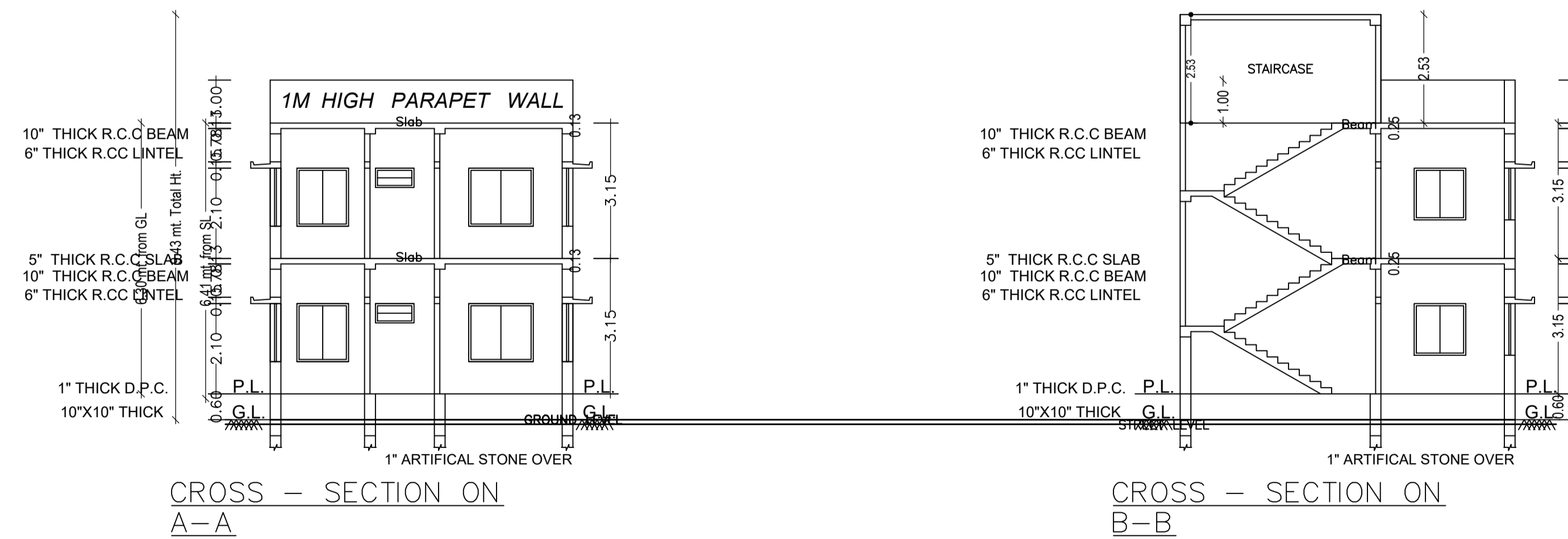

CROSS - SECTION ON
A-A

CROSS - SECTION ON
B-B

UnitBUA Table for Building :A (FOR SAYIDA KHATUN)

FLOOR	Name	UnitBUA Type	UnitBUA Area	Carpet Area	No. of Rooms	No. of Tenement
GROUND FLOOR PLAN	SPLIT F-1	FLAT	79.68	79.28	6	1
FIRST FLOOR PLAN	SPLIT F-1	FLAT	0.00	0.00	6	0
Total:	-	-	79.68	79.28	12	1

SCHEDULE OF DOOR:

BUILDING NAME	NAME	LENGTH	HEIGHT	NOS
A (FOR SAYIDA KHATUN)	D2	0.75	2.10	04
A (FOR SAYIDA KHATUN)	D	1.05	2.10	06

SCHEDULE OF WINDOW/VENTILATION:

BUILDING NAME	NAME	LENGTH	HEIGHT	NOS
A (FOR SAYIDA KHATUN)	HLW	0.90	0.60	02
A (FOR SAYIDA KHATUN)	W4	1.20	1.20	04
A (FOR SAYIDA KHATUN)	W5	1.50	1.35	04
A (FOR SAYIDA KHATUN)	W6	1.80	1.35	02

Building :A (FOR SAYIDA KHATUN)

Floor Name	Total Built Up Area (Sq.mt.)	Proposed FAR Area (Sq.mt.) Resi.	Total FAR Area (Sq.mt.)	Total Consumed Additional FAR Area (Sq.mt.)	Tnmt (No.)
Ground Floor	54.60	54.60	54.60	54.60	01
First Floor	54.60	54.60	54.60	54.60	00
Terrace Floor	0.00	0.00	0.00	0.00	00
Total :	109.20	109.20	109.20	109.20	01
Total Number of Same Buildings :	1				
Total :	109.20	109.20	109.20	109.20	01

LTP NAME AND SIGNATURE	STRUCTURAL ENG'S NAME AND SIGNATURE	BUILDER NAME AND SIGNATURE	DIGITAL SIGNATURE
RAJKISHOR KUMAR MNP/ENG/0003/2018			

Proposal Basic Information	
Proposal File No.	MNP/BP/0012/W09/2020
Owner Name	SAYIDA KHATUN
Khata No	30
Plot No	NA
Village Name	Madhupur Khas
Use	Residential
SubUse	Bungalow/ Dwelling / Non Apartment

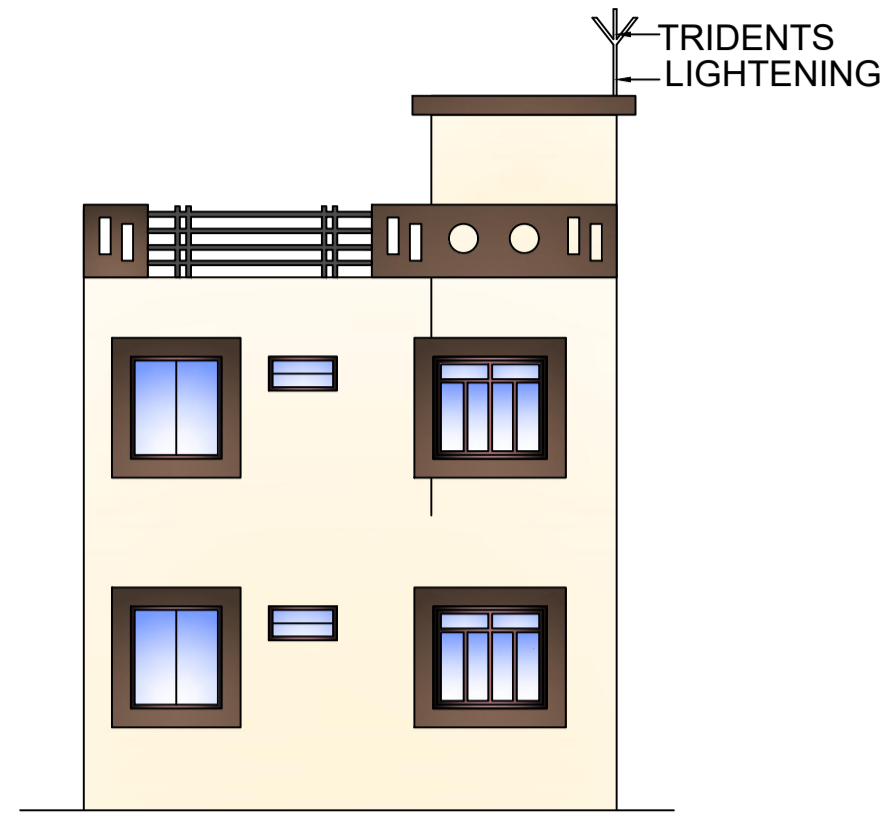

SIDE ELEVATION

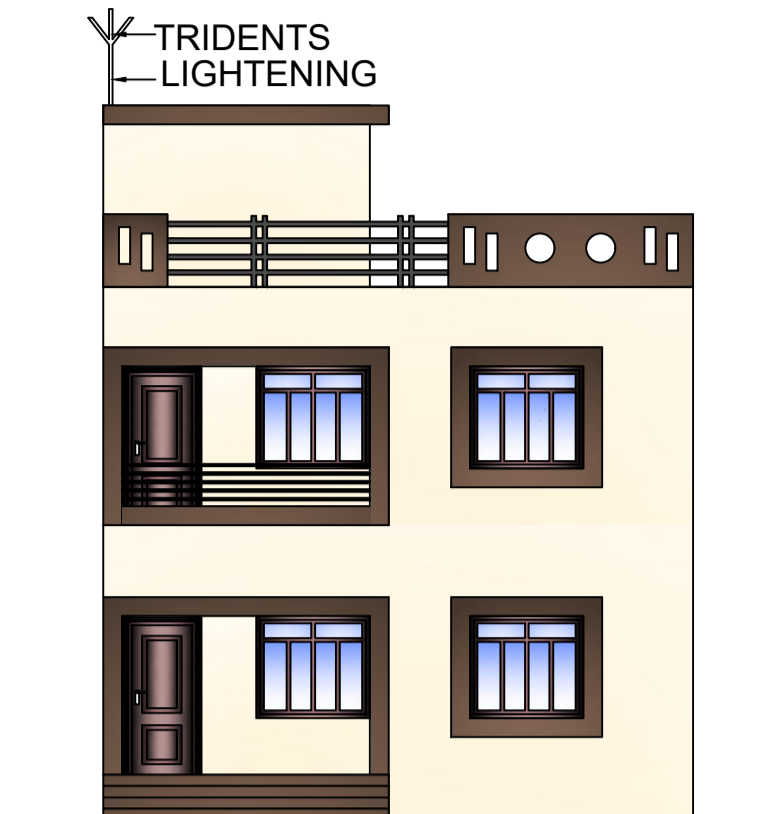

FRONT ELEVATION

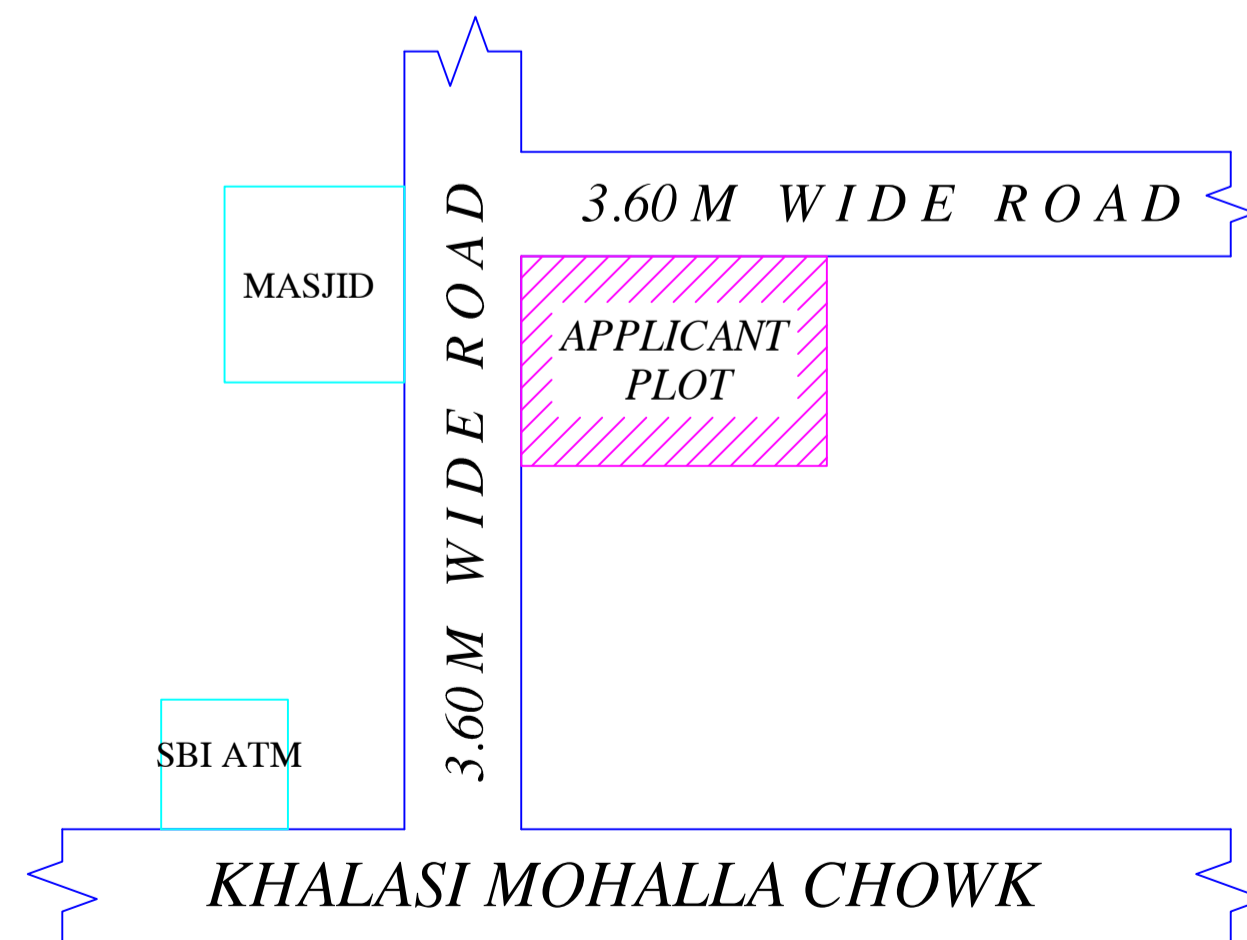
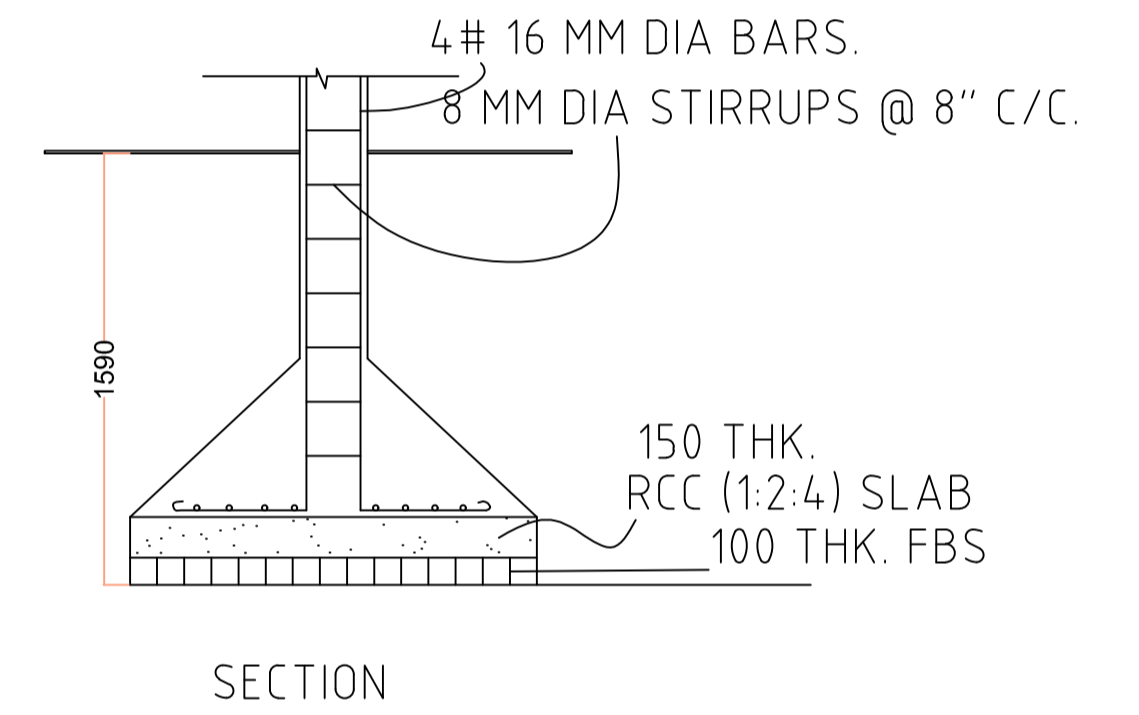
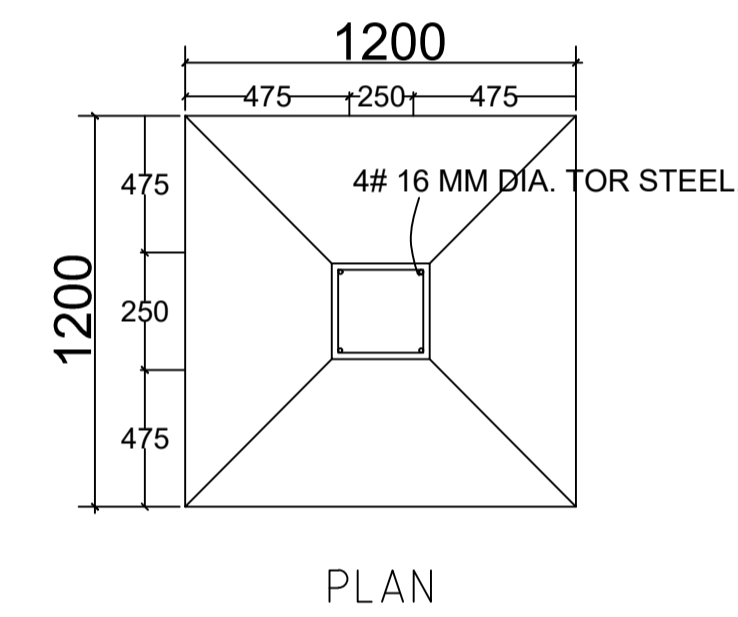
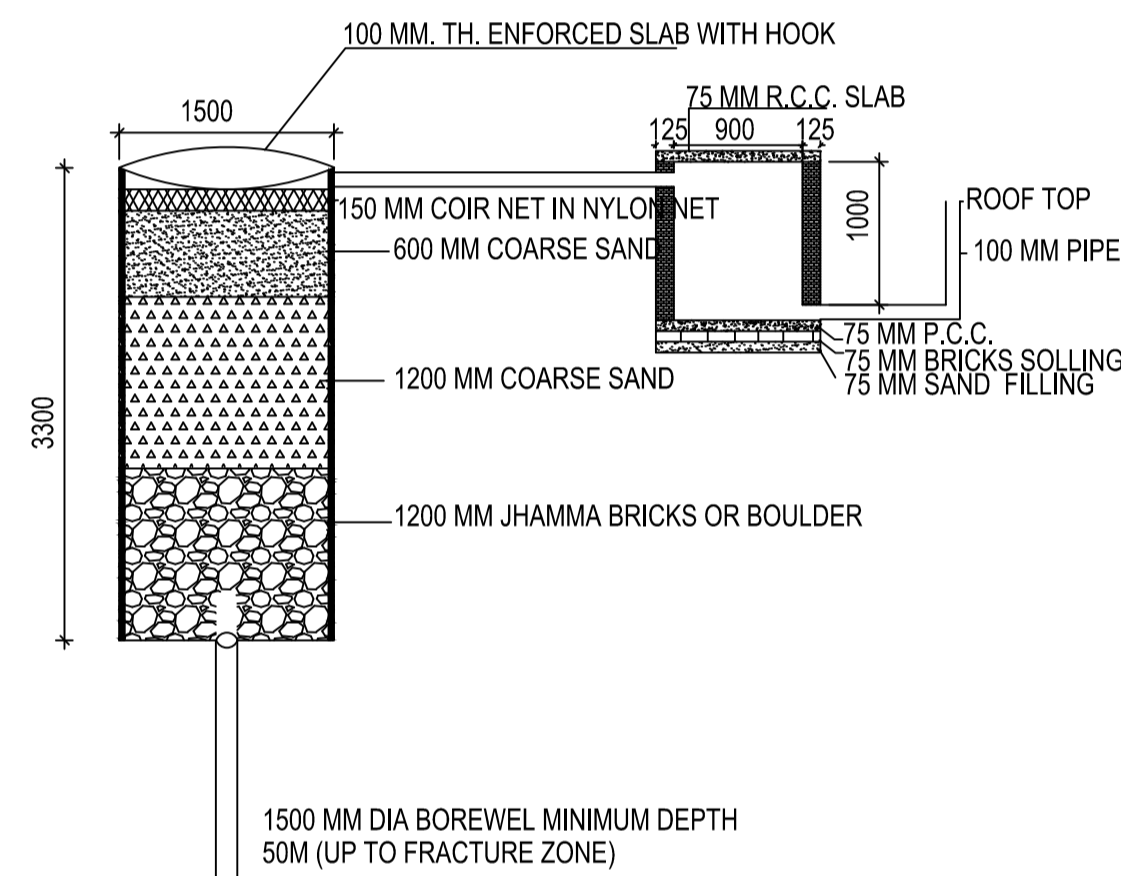
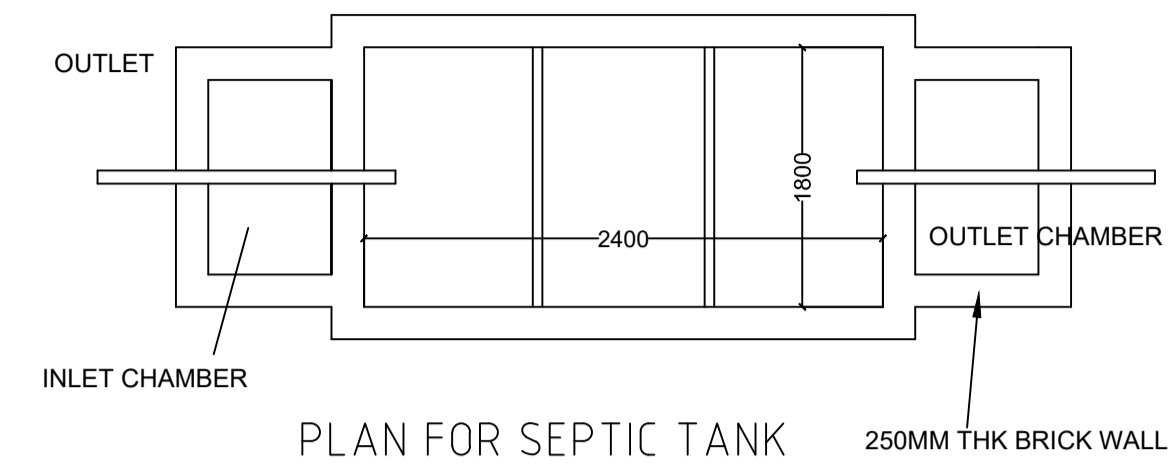
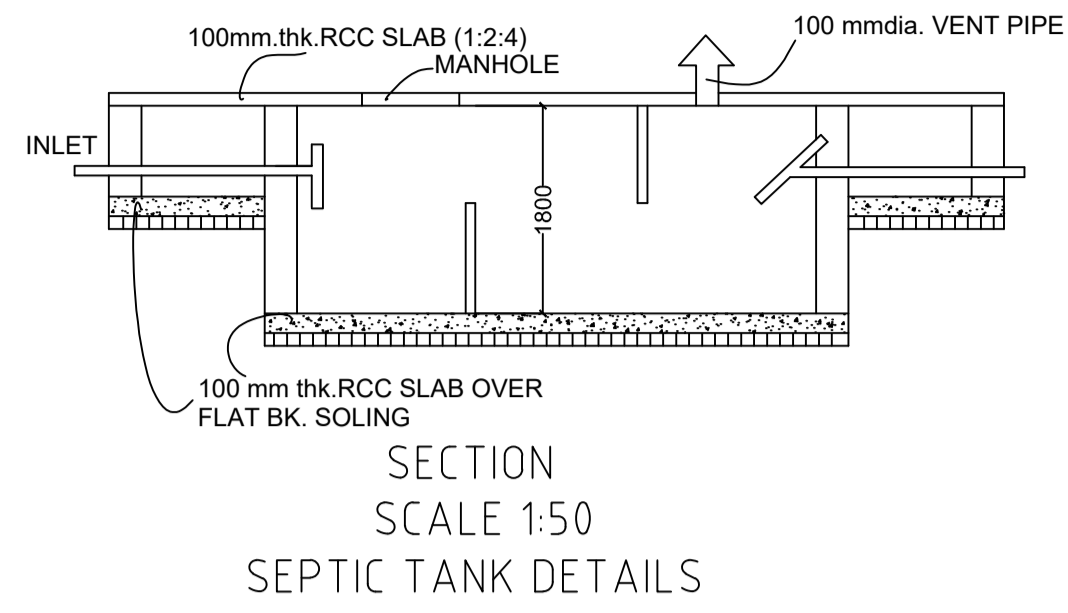

This is certify that the structure design is in accordance with the latest I-S code(I-S 875,1-S456-2002, I-S 1893-2000) for design & loading conditions (Sessmic/wind/dead/live) and other all parameters are taken in account for safetyof the structure.

LTP NAME AND SIGNATURE	STRUCTURAL ENG'S NAME AND SIGNATURE	BUILDER NAME AND SIGNATURE	DIGITAL SIGNATURE
RAJKISHOR KUMAR MNP/ENG/0003/2018			