

Proposal Basic Information

Proposal File No.	MNP/EP/0029/W08/2020
Owner Name	KRISHNA MURARI BATHWAL
Khata No	33/A
Plot No	NA
Village Name	Madhupur Bazar
Use	Residential
SubUse	Bungalow/ Dwelling / Non Apartment

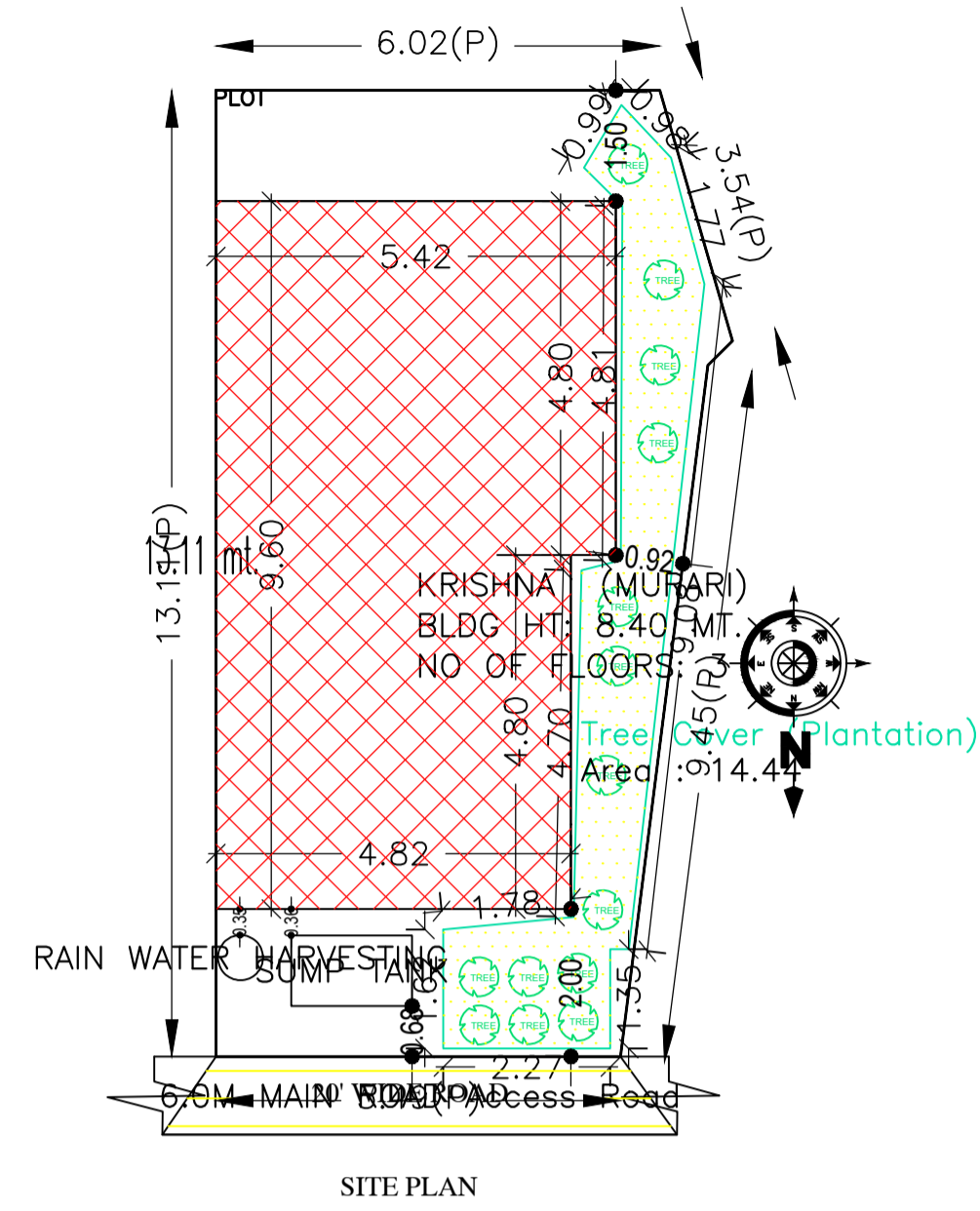

AREA STATEMENT MADHUPUR NAGAR PARISHAD	VERSION NO.: 1.0.50 VERSION DATE: 16/10/2020
PROJECT DETAIL:	
Region: JHARKHAND URBAN LOCAL BODIES	Plot Use: Residential
District: DEOGHAR	Plot SubUse: Bungalow/ Dwelling / Non Apartment
Authority: MADHUPUR NAGAR PARISHAD	PlotNearbyReligiousStructure: NA
Inward No: MNP/EP/0029/W08/2020	Plot/SubPlot No: NA
Application Type: General Proposal	North: Road Width - 6.0
Project Type: Building Permission	South: Plot No. - HOUSE OF KALI PD. CHOUDHARY
Nature of Development: New	East: Plot No. - VENDORS LAND
Location of Development Area: Old Area	West: Plot No. - HOUSE OF SITA TUNADARIYA
AREA DETAILS:	
AREA OF PLOT (Minimum)	(A) 81.41 SQ.MT.
NET AREA OF PLOT(Gross Plot Area - Deduction from Gross Plot area)	(A-Deductions) 81.41
Deduction for Balance Plot Area(from Gross Plot Area)	
Common Plot	14.44
Total	14.44
BALANCE AREA OF PLOT(Net Plot Area - Recreational/Amenity space)	(A-Deductions) 66.97
PLOT AREA FOR COVERAGE(Net Plot Area)	(A-Deductions) 81.41
Plot Area for FAR (Net Plot Area + RoadWidening Area)	(A-Deductions) 81.41
COVERAGE CHECK	
Permissible Coverage area (70.00 %)	56.99
Proposed Coverage Area (60.37 %)	49.15
Total Prop. Coverage Area (60.37 %)	49.15
Balance coverage area (9.63 %)	7.84
FAR CHECK	
Perm. FAR Area (1.80)	146.54
Total Perm. FAR area	146.54
Residential FAR	128.49
Proposed FAR Area	128.49
Total Proposed FAR Area	128.49
Consumed FAR (Factor)	1.58
Balance FAR Area	18.05
BUILT UP AREA CHECK	
Total Proposed BuiltUp Area	147.47
ARCHITECT (Regd)	RAJKISHOR KUMAR
ENGINEER (Regd)	
SUPERVISOR (Regd)	
OWNER (Regd)	KRISHNA MURARI BATHWAL
DEVELOPMENT AUTHORITY	LOCAL BODY

COLOR INDEX	
PLOT BOUNDARY	Black
ABUTTING ROAD	Green
PROPOSED CONSTRUCTION	Red
COMMON PLOT	Yellow
ROAD WIDENING AREA	Blue
EXISTING (To be retained)	Light Blue
EXISTING (To be demolished)	Dark Blue

Building USE/SUBUSE Details

Building Name	Building Use	Building SubUse	Building Structure
KRISHNA (MURARI)	Residential	Bungalow/ Dwelling / Non Apartment	Non-Highrise

Buildingwise Floor FAR Details

Floor Name	Building Name KRISHNA (MURARI)		Total	
	Proposed Built Up Area (Sq.mt.)	Proposed FAR Area (Sq.mt.)	Total Proposed Built Up Area (Sq.mt.)	Total FAR Area (Sq.mt.)
Ground Floor	49.15	49.15	49.15	49.15
First Floor	49.16	39.67	49.16	39.67
Second Floor	49.16	39.67	49.16	39.67
Terrace Floor	0.00	0.00	0.00	0.00
Total :	147.47	128.49	147.47	128.49

FAR & Tenement Details (Table 4c-1)

Building	No. of Same Bldg	Total Built Up Area (Sq.mt.)	Deductions (Area in Sq.mt.)	Proposed FAR Area (Sq.mt.)	Total FAR Area (Sq.mt.)	Total Consumed Additional FAR Area (Sq.mt.)	Tnmt (No.)
KRISHNA (MURARI)	1	147.47	18.98	128.49	128.49	128.49	01
Grand Total :	1	147.47	18.98	128.49	128.49	128.49	01

LTP NAME AND SIGNATURE	STRUCTURAL ENG'S NAME AND SIGNATURE	BUILDER NAME AND SIGNATURE	DIGITAL SIGNATURE
RAJKISHOR KUMAR MNP/ENG/0003/2018			

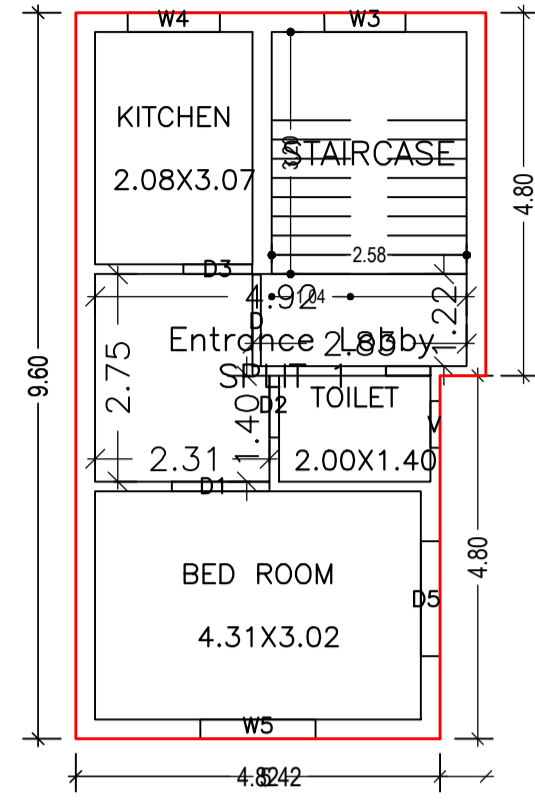

FIRST FLOOR PLAN
(Proposed)
(SCALE 1:100)

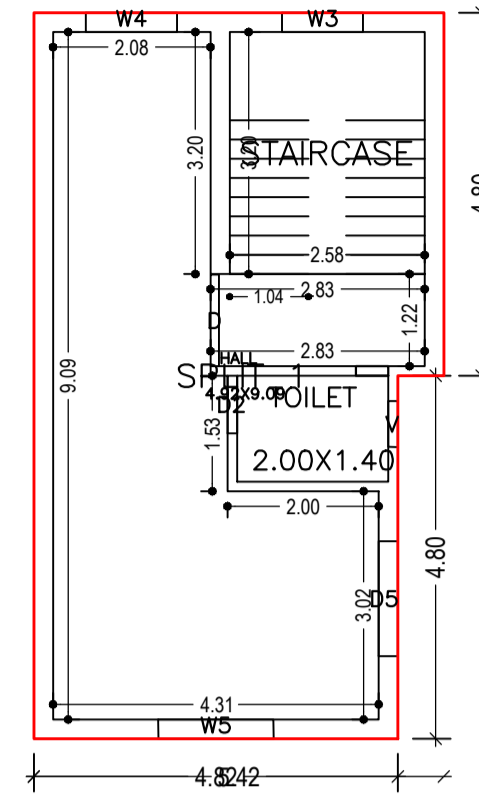

GROUND FLOOR PLAN
(Proposed)
(SCALE 1:100)

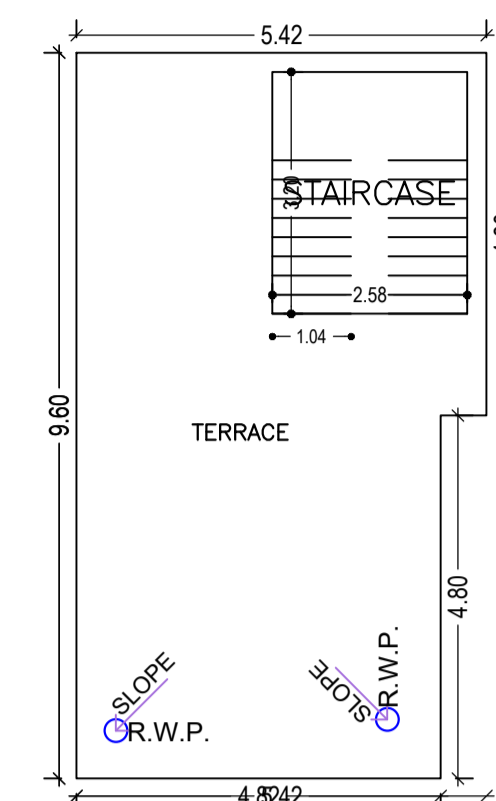

TERRACE FLOOR PLAN
(SCALE 1:100)

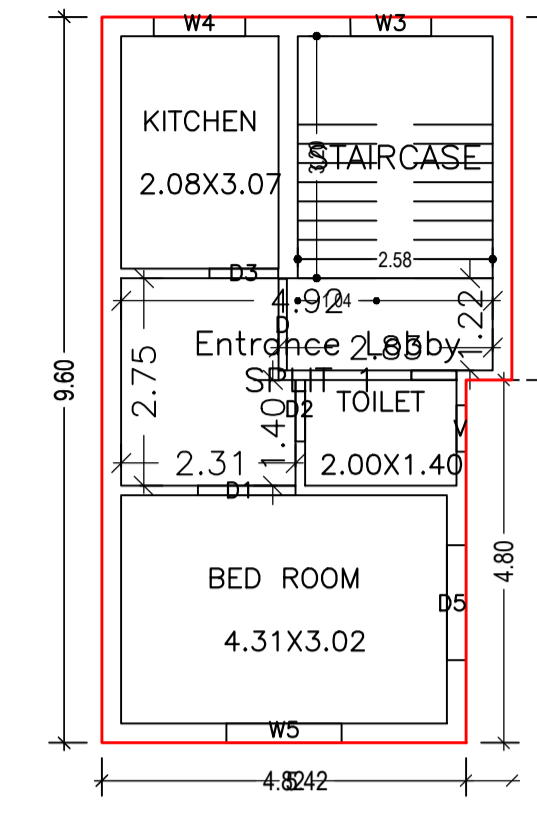

SECOND FLOOR PLAN
(Proposed)
(SCALE 1:100)

Proposal Basic Information	
Proposal File No.	MNP/EP/0029/W08/2020
Owner Name	KRISHNA MURARI BATHWAL
Khata No	33/A
Plot No	NA
Village Name	Madhupur Bazar
Use	Residential
SubUse	Bungalow/ Dwelling / Non Apartment

Building :KRISHNA (MURARI)

Floor Name	Total Built Up Area (Sq.mt.)	Deductions (Area in Sq.mt.)		Proposed FAR Area (Sq.mt.)	Total FAR Area (Sq.mt.)	Total Consumed Additional FAR Area (Sq.mt.)	Trmt (No.)
		Accessory Use	Resi.				
Ground Floor	49.15	0.00	49.15	49.15	49.15	01	
First Floor	49.16	9.49	39.67	39.67	39.67	00	
Second Floor	49.16	9.49	39.67	39.67	39.67	00	
Terrace Floor	0.00	0.00	0.00	0.00	0.00	00	
Total :	147.47	18.98	128.49	128.49	128.49	01	
Total Number of Same Buildings :	1						
Total :	147.47	18.98	128.49	128.49	128.49	01	

SCHEDULE OF DOOR:

BUILDING NAME	NAME	LENGTH	HEIGHT	NOS
KRISHNA (MURARI)	D2	0.76	2.10	01
KRISHNA (MURARI)	D2	0.81	2.10	01
KRISHNA (MURARI)	D2	0.82	2.10	01
KRISHNA (MURARI)	D3	0.91	2.10	02
KRISHNA (MURARI)	D	1.21	2.10	01
KRISHNA (MURARI)	D1	1.29	2.10	02

SCHEDULE OF WINDOW/VENTILATION:

BUILDING NAME	NAME	LENGTH	HEIGHT	NOS
KRISHNA (MURARI)	V	0.61	1.20	01
KRISHNA (MURARI)	V	0.62	1.20	02
KRISHNA (MURARI)	W3	1.07	1.20	02
KRISHNA (MURARI)	W3	1.08	1.20	01
KRISHNA (MURARI)	W4	1.21	1.20	02
KRISHNA (MURARI)	W4	1.22	1.20	01
KRISHNA (MURARI)	D5	1.52	1.20	03
KRISHNA (MURARI)	W5	1.52	1.20	03

UnitBUA Table for Building :KRISHNA (MURARI)

FLOOR	Name	UnitBUA Type	UnitBUA Area	Carpet Area	No. of Rooms	No. of Tenement
FIRST FLOOR PLAN	SPLIT 1	FLAT	0.00	0.00	3	0
GROUND FLOOR PLAN	SPLIT 1	FLAT	98.95	98.75	2	1
SECOND FLOOR PLAN	SPLIT 1	FLAT	0.00	0.00	3	0
Total:	-	-	98.95	98.75	8	1

LTP NAME AND SIGNATURE	STRUCTURAL ENG'S NAME AND SIGNATURE	BUILDER NAME AND SIGNATURE	DIGITAL SIGNATURE
RAJKISHOR KUMAR MNP/ENG/0003/2018			

Proposal Basic Information

Proposal File No.	MNP/EP/0029/W08/2020
Owner Name	KRISHNA MURARI BATHWAL
Khata No	33/A
Plot No	NA
Village Name	Madhupur Bazar
Use	Residential
SubUse	Bungalow/ Dwelling / Non Apartment

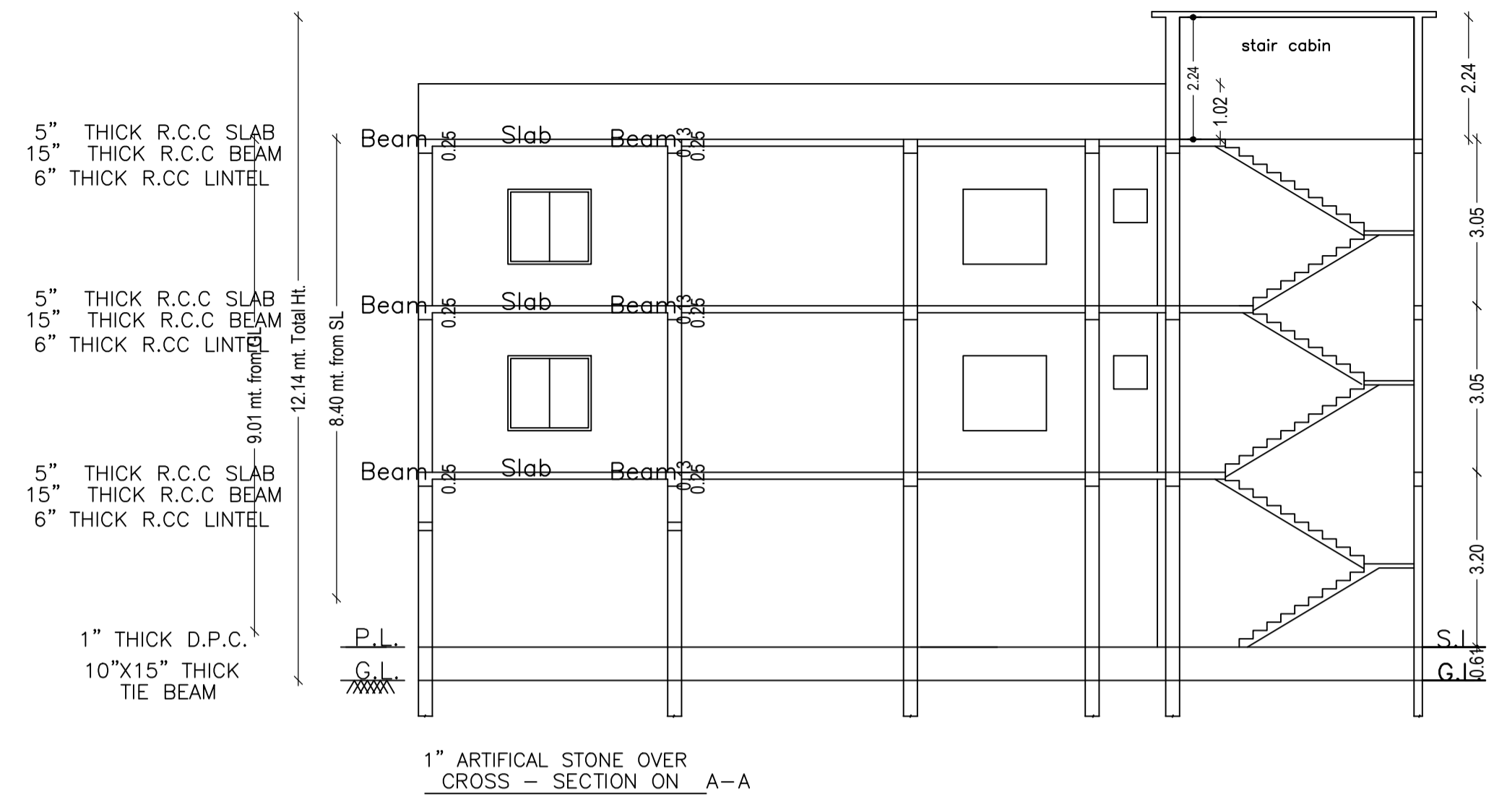

1" ARTIFICIAL STONE OVER
CROSS - SECTION ON A-A

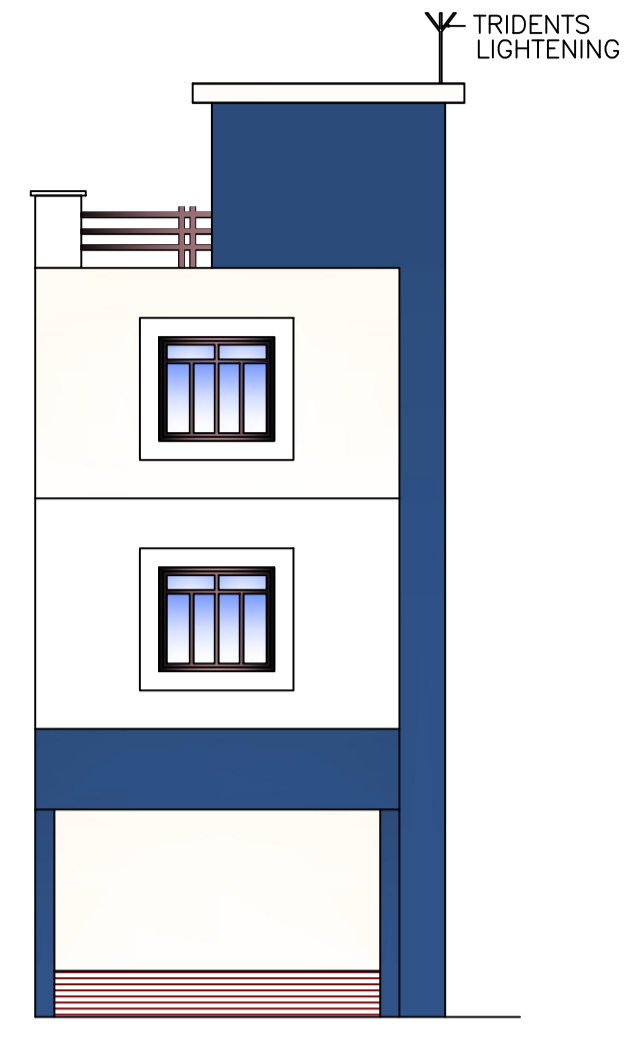

FRONT ELEVATION

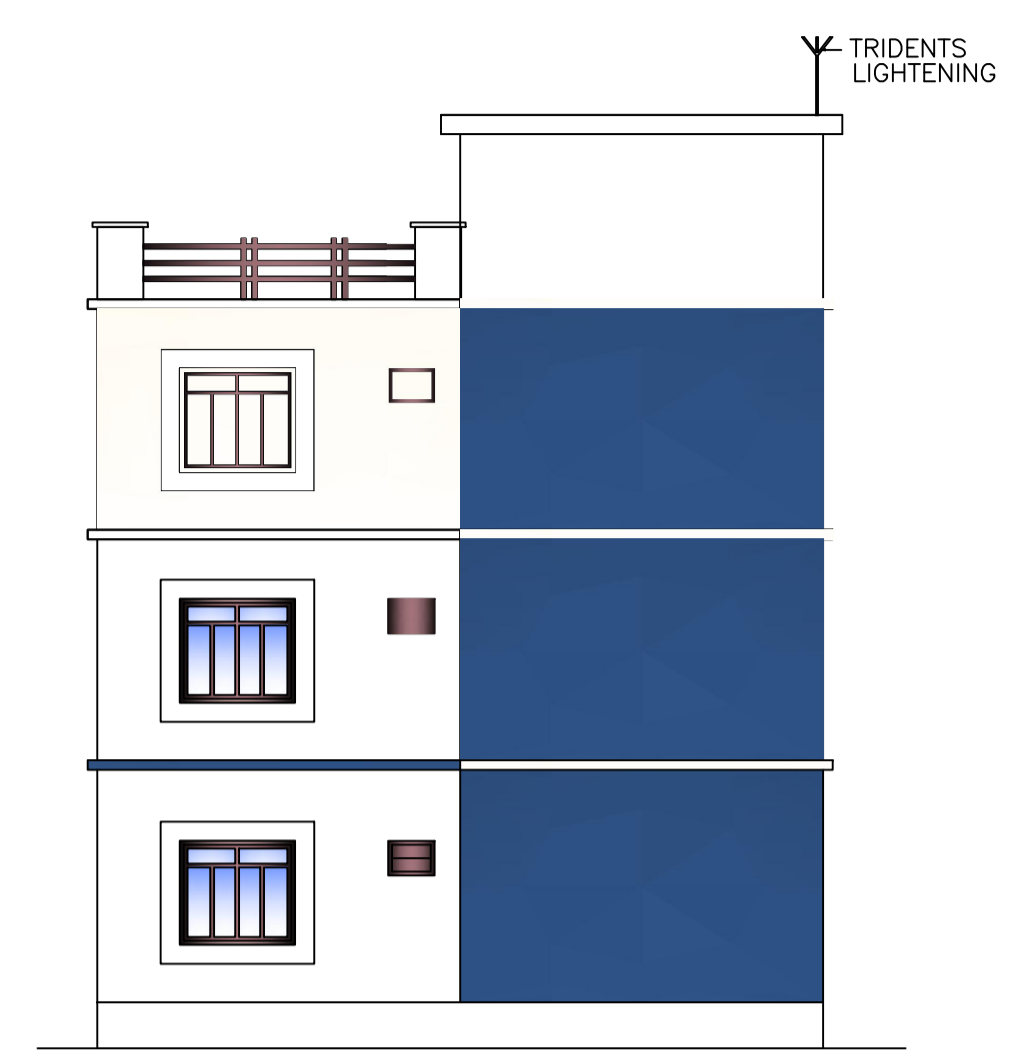

R.H.S VIEW

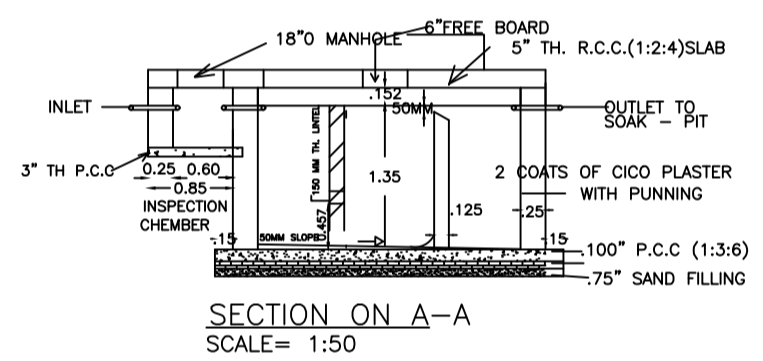
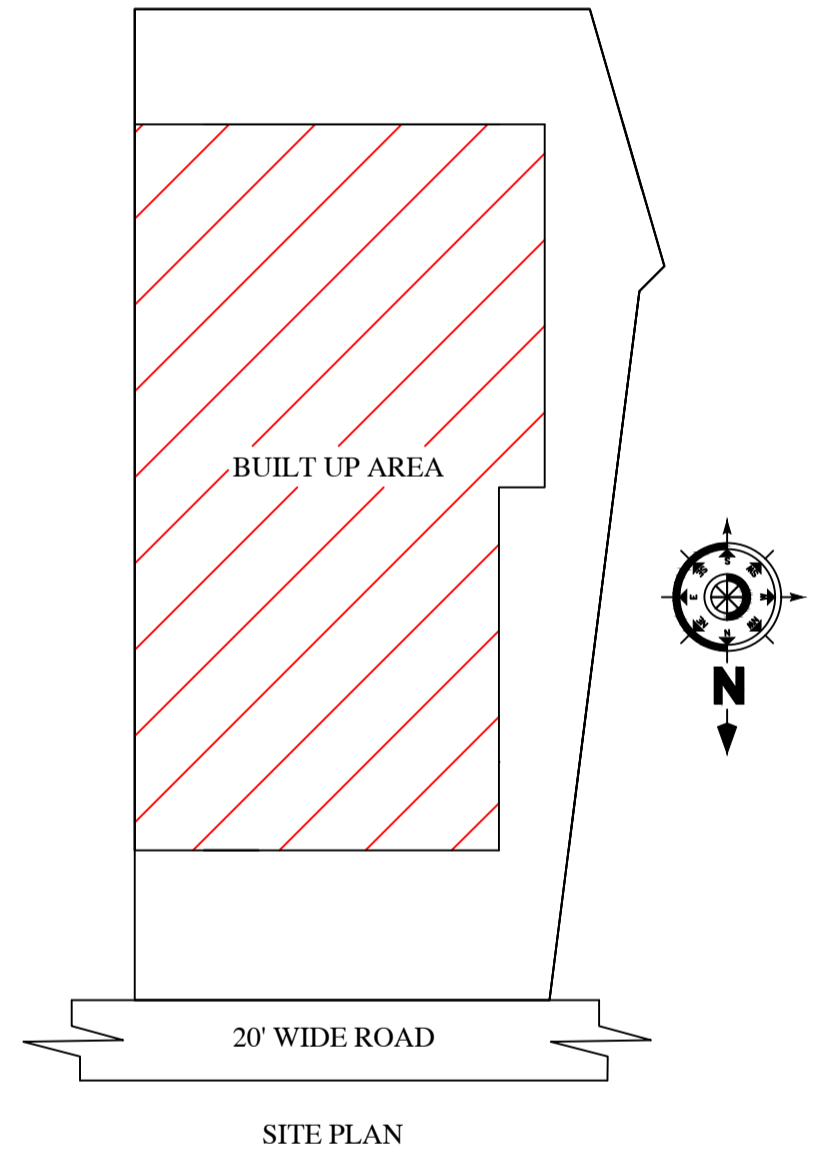
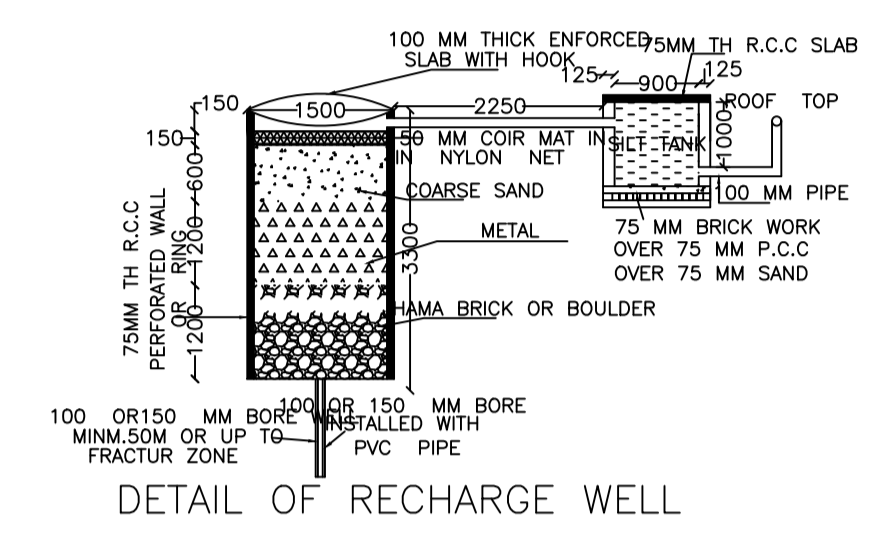

SECTION ON A-A
SCALE= 1:50

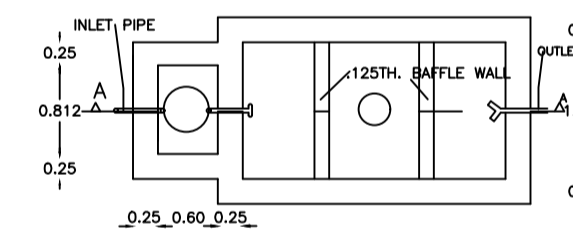

SEPTIC TANK PLAN
SCALE= 1:50

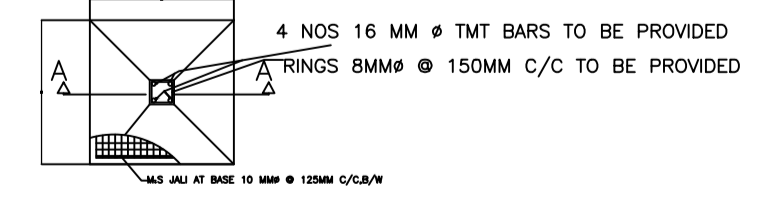
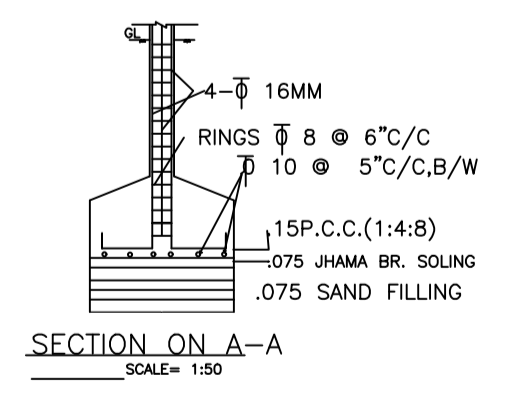
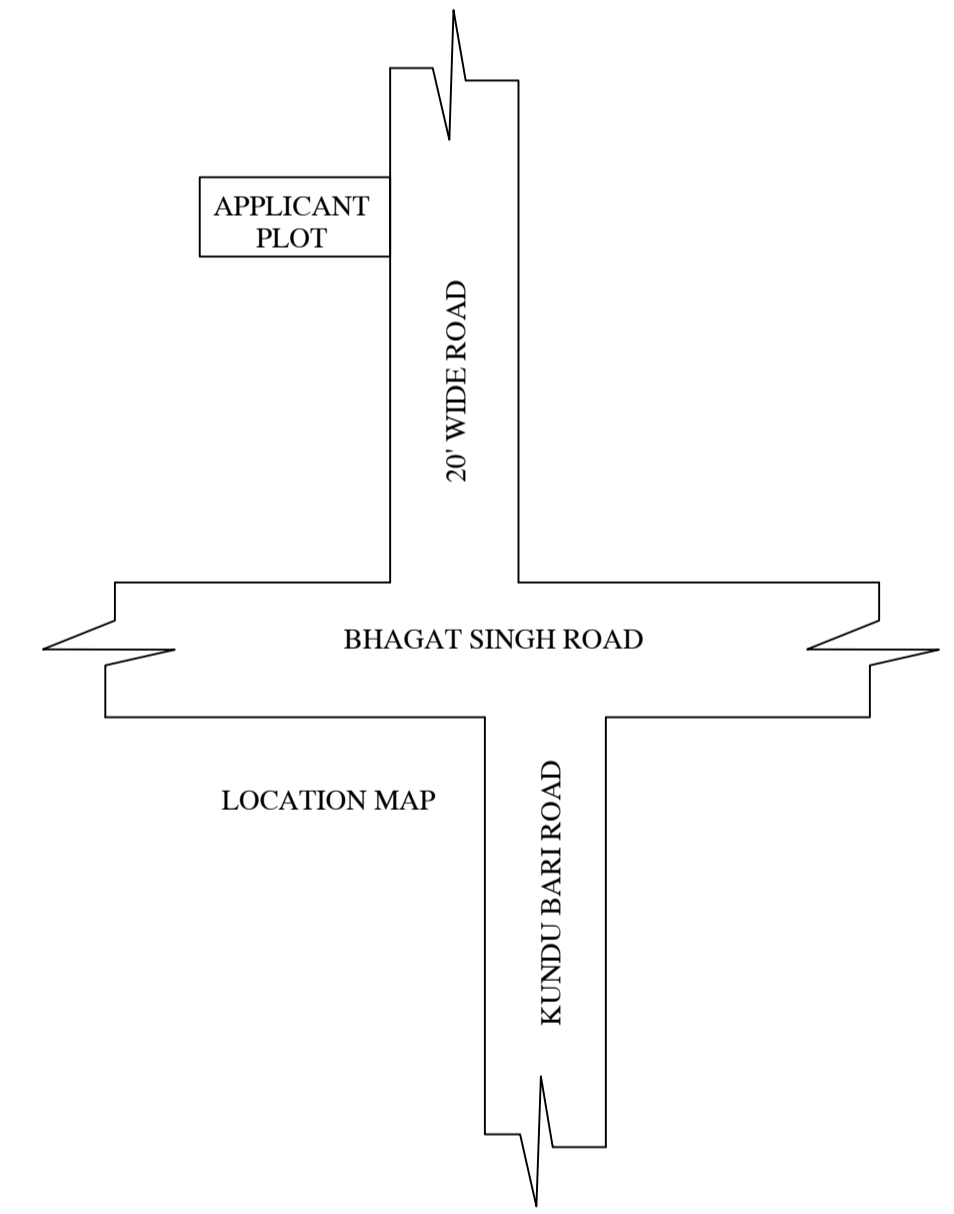

PLAN OF COLUMN FOUNDATION
SCALE= 1:50

This is certify that the structure design is in accordance with the latest I-S code(I-S 875,I-S456-2002, I-S 1893-2000) for design & loading conditions (Sessmic/wind/dead/live) and other all parameters are taken in account for safetyof the structure.

LTP NAME AND SIGNATURE	STRUCTURAL ENG'S NAME AND SIGNATURE	BUILDER NAME AND SIGNATURE	DIGITAL SIGNATURE
RAJKISHOR KUMAR MNP/ENG/0003/2018			