

AREA STATEMENT MADHUPUR NAGAR PARISHAD	VERSION NO.: 1.0.60 VERSION DATE: 16/10/2020		
PROJECT DETAIL:			
Region: JHARKHAND URBAN LOCAL BODIES	Plot Use: Residential		
District: DEOGHAR	Plot SubUse: Bungalow/ Dwelling / Non Apartment		
Authority: MADHUPUR NAGAR PARISHAD	PlotNearby/ReligiousStructure: NA		
Inward No: MNP/BP/0030/W18/2021	Plot/SubPlot No: 814		
Application Type: General Proposal	North: Plot No. - VENDORS LAND		
Project Type: Building Permission	South: Plot No. - VENDORS LAND		
Nature of Development: New	East: Road Width - 3.65		
Location of Development Area: Old Area	West: Plot No. - VENDORS LAND		
AREA DETAILS:			
AREA OF PLOT (Minimum)	(A)	SQ.MT.	154.42
NET AREA OF PLOT(Gross Plot Area - Deduction from Gross Plot area)	(A-Deductions)		154.42
Deduction for Balance Plot Area(from Gross Plot Area)			
Common Plot			16.82
Total			16.82
BALANCE AREA OF PLOT(Net Plot Area - Recreational/Amenity space)	(A-Deductions)		137.61
PLOT AREA FOR COVERAGE(Net Plot Area)	(A-Deductions)		154.42
Plot Area for FAR (Net Plot Area + RoadWidening Area)	(A-Deductions)		154.42
COVERAGE CHECK			
Permissible Coverage area (70.00 %)			108.09
Proposed Coverage Area (62.39 %)			96.34
Total Prop. Coverage Area (62.39 %)			96.34
Balance coverage area (7.61 %)			11.75
FAR CHECK			
Perm. FAR Area (1.50)			231.63
Total Perm. FAR area			231.63
Residential FAR			192.68
Proposed FAR Area			192.68
Total Proposed FAR Area			192.68
Consumed FAR (Factor)			1.25
Balance FAR Area			38.95
BUILT UP AREA CHECK			
Total Proposed BuiltUp Area			192.68
ARCHITECT (Regd)	VISHAL YADAV		
ENGINEER (Regd)			
SUPERVISOR (Regd)			
OWNER (Regd)	FULKUMARI DEVI		
DEVELOPMENT AUTHORITY		LOCAL BODY	

Proposal Basic Information	
Proposal File No.	MNP/BP/0030/W18/2021
Owner Name	FULKUMARI DEVI
Khata No	221
Plot No	814
Village Name	Patharchptti
Use	Residential
SubUse	Bungalow/ Dwelling / Non Apartment

Building USE/SUBUSE Details

Building Name	Building Use	Building SubUse	Building Structure
A (BUILDING)	Residential	Bungalow/ Dwelling / Non Apartment	Non-Highrise

FAR & Tenement Details (Table 4c-1)

Building	No. of Same Bldg	Total Built Up Area (Sq.mt.)	Proposed FAR Area (Sq.mt.) Resi.	Total FAR Area (Sq.mt.)	Total Consumed Additional FAR Area (Sq.mt.)	Tnmt (No.)
A (BUILDING)	1	192.68	192.68	192.68	192.68	01
Grand Total :	1	192.68	192.68	192.68	192.68	01

Buildingwise Floor FAR Details

Floor Name	Building Name A (BUILDING)		Total	
	Proposed Built Up Area (Sq.mt.)	Proposed FAR Area (Sq.mt.)	Total Proposed Built Up Area (Sq.mt.)	Total FAR Area (Sq.mt.)
Ground Floor	96.34	96.34	96.34	96.34
First Floor	96.34	96.34	96.34	96.34
Terrace Floor	0.00	0.00	0.00	0.00
Total :	192.68	192.68	192.68	192.68

COLOR INDEX	
PLOT BOUNDARY	[Red Line]
ABUTTING ROAD	[Green Line]
PROPOSED CONSTRUCTION	[Blue Line]
COMMON PLOT	[Yellow Line]
ROAD WIDENING AREA	[Orange Line]
EXISTING (To be retained)	[Purple Line]
EXISTING (To be demolished)	[Light Blue Line]

LTP NAME AND SIGNATURE	STRUCTURAL ENG'S NAME AND SIGNATURE	BUILDER NAME AND SIGNATURE	DIGITAL SIGNATURE
VISHAL YADAV MNP/ENG/0006/2020			

Proposal Basic Information

Proposal File No.	MNP/BP/0030/W18/2021
Owner Name	FULKUMARI DEVI
Khata No	221
Plot No	814
Village Name	Patharchptti
Use	Residential
SubUse	Bungalow/ Dwelling / Non Apartment

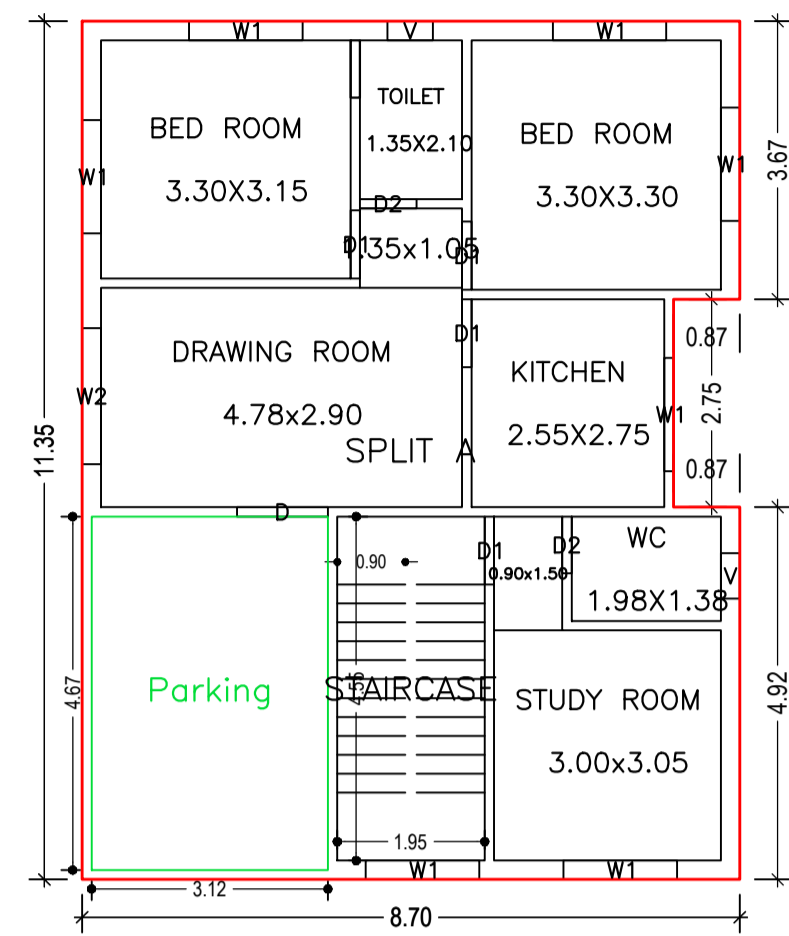

GROUND FLOOR PLAN
(Proposed)
(SCALE 1:100)

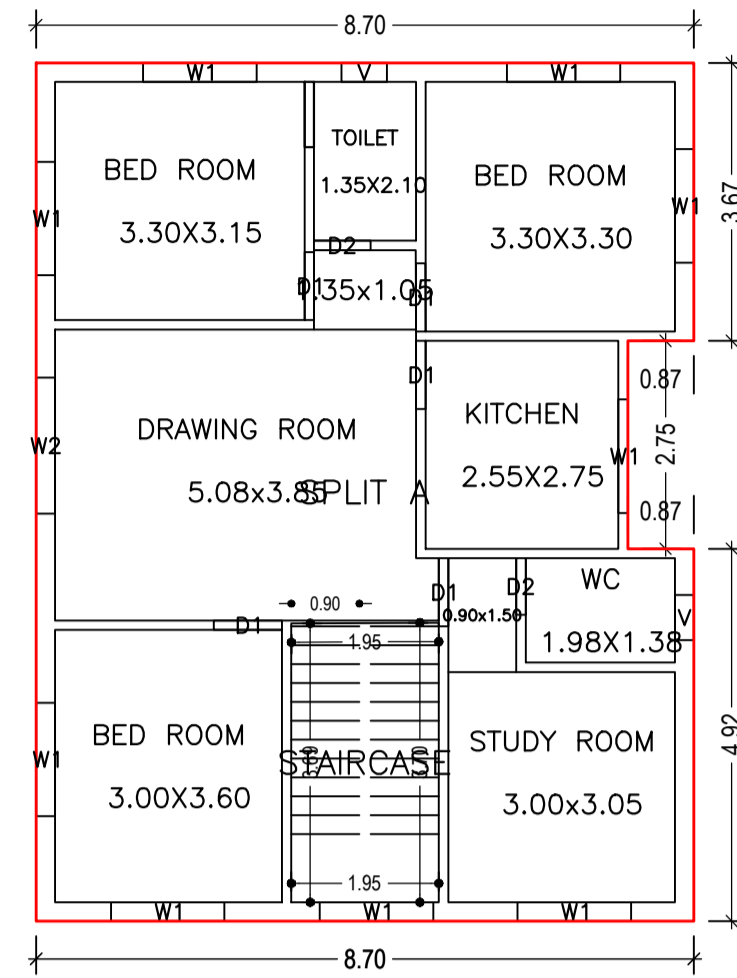

FIRST FLOOR PLAN
(Proposed)
(SCALE 1:100)

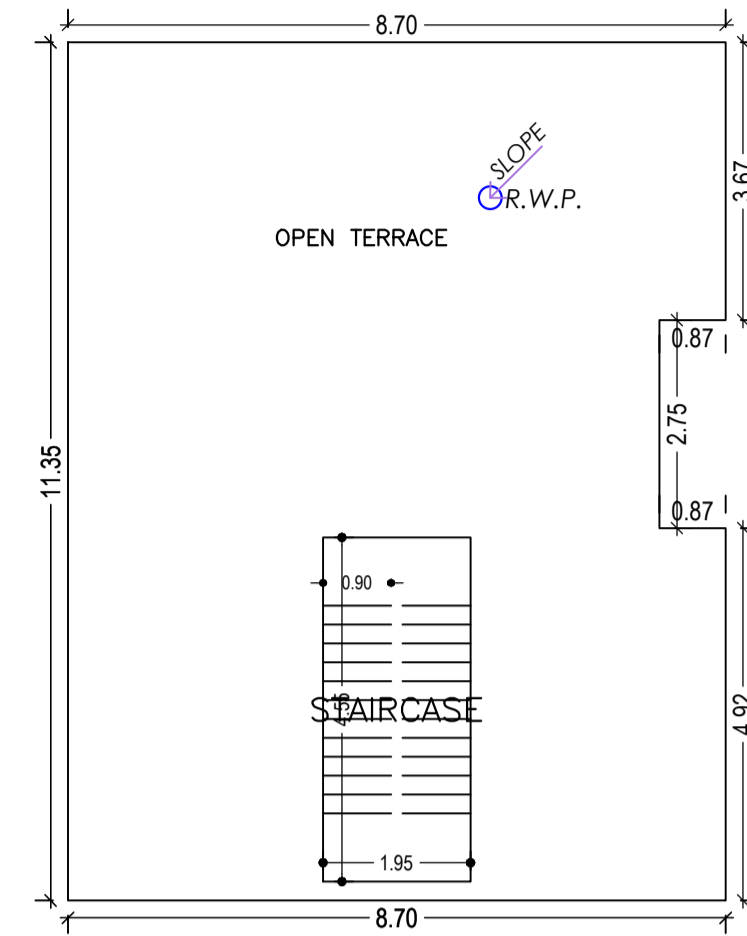

TERRACE FLOOR PLAN
(SCALE 1:100)



FRONT ELEVATION
SCALE :- 1:100

UnitBUA Table for Building :A (BUILDING)

FLOOR	Name	UnitBUA Type	UnitBUA Area	Carpet Area	No. of Rooms	No. of Tenement
GROUND FLOOR PLAN	SPLIT A	FLAT	140.93	140.73	7	1
FIRST FLOOR PLAN	SPLIT A	FLAT	0.00	0.00	8	0
Total:	-	-	140.93	140.73	15	1

SCHEDULE OF DOOR:

BUILDING NAME	NAME	LENGTH	HEIGHT	NOS
A (BUILDING)	D2	0.75	2.10	04
A (BUILDING)	D1	0.90	2.10	09
A (BUILDING)	D	1.20	2.10	01

SCHEDULE OF WINDOW/VENTILATION:

BUILDING NAME	NAME	LENGTH	HEIGHT	NOS
A (BUILDING)	V	0.60	0.60	04
A (BUILDING)	W1	1.50	1.20	16
A (BUILDING)	W2	1.80	1.20	02

Building :A (BUILDING)

Floor Name	Total Built Up Area (Sq.mt.)	Proposed FAR Area (Sq.mt.) Resi.	Total FAR Area (Sq.mt.)	Total Consumed Additional FAR Area (Sq.mt.)	Tnmt (No.)
Ground Floor	96.34	96.34	96.34	96.34	01
First Floor	96.34	96.34	96.34	96.34	00
Terrace Floor	0.00	0.00	0.00	0.00	00
Total :	192.68	192.68	192.68	192.68	01
Total Number of Same Buildings :	1				
Total :	192.68	192.68	192.68	192.68	01

LTP NAME AND SIGNATURE	STRUCTURAL ENG'S NAME AND SIGNATURE	BUILDER NAME AND SIGNATURE	DIGITAL SIGNATURE
VISHAL YADAV MNP/ENG/0006/2020			

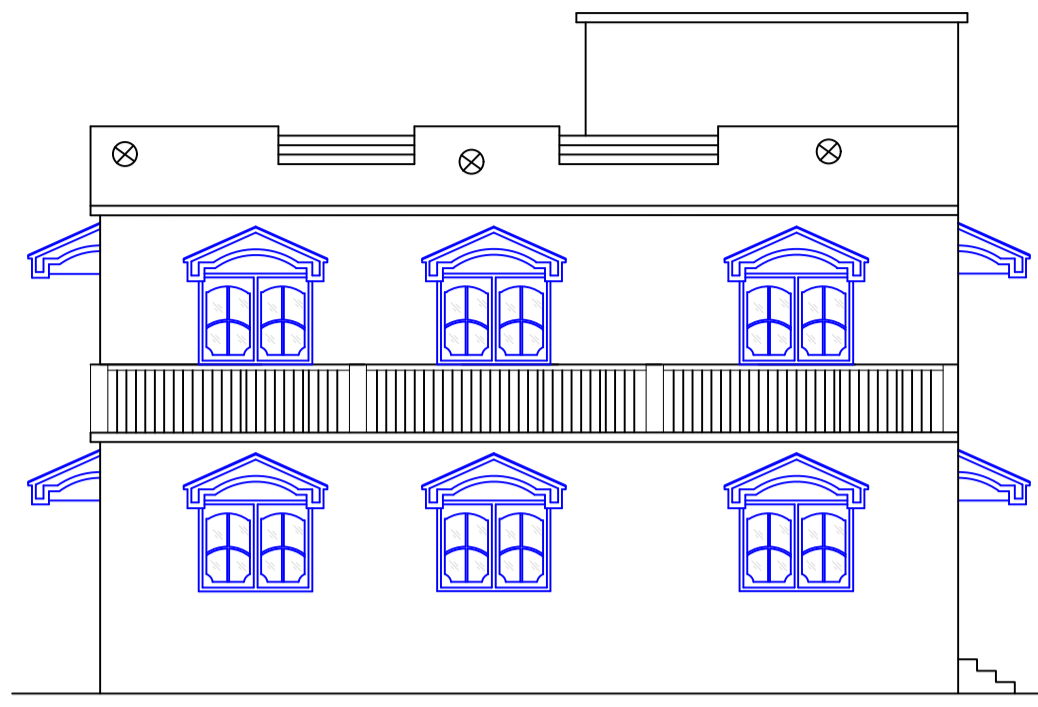

RIGHT SIDE ELEVATION
SCALE :- 1:100

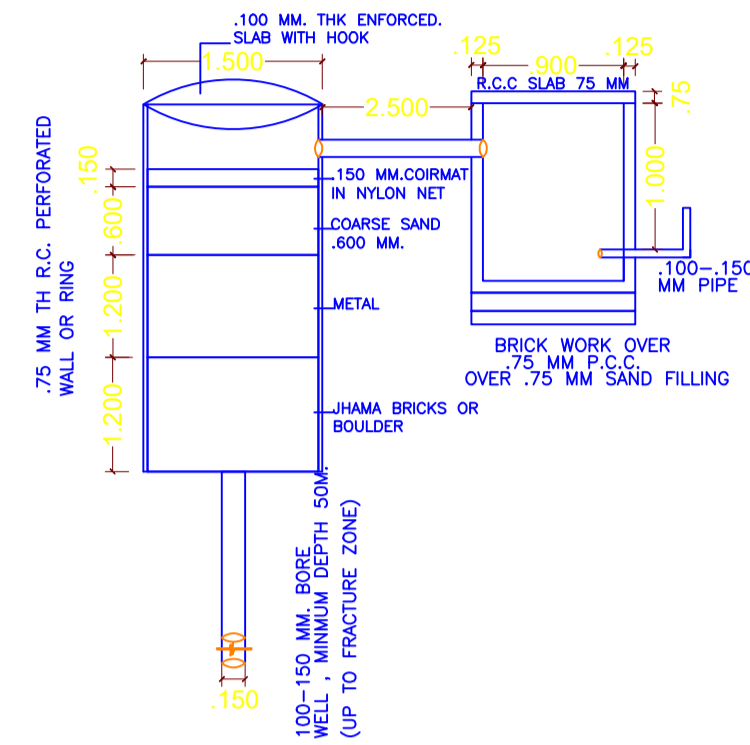

DETAIL OF GROUND WATER RECHAREGING PIT WITH SLIT TANK
(SCALE 1:50)

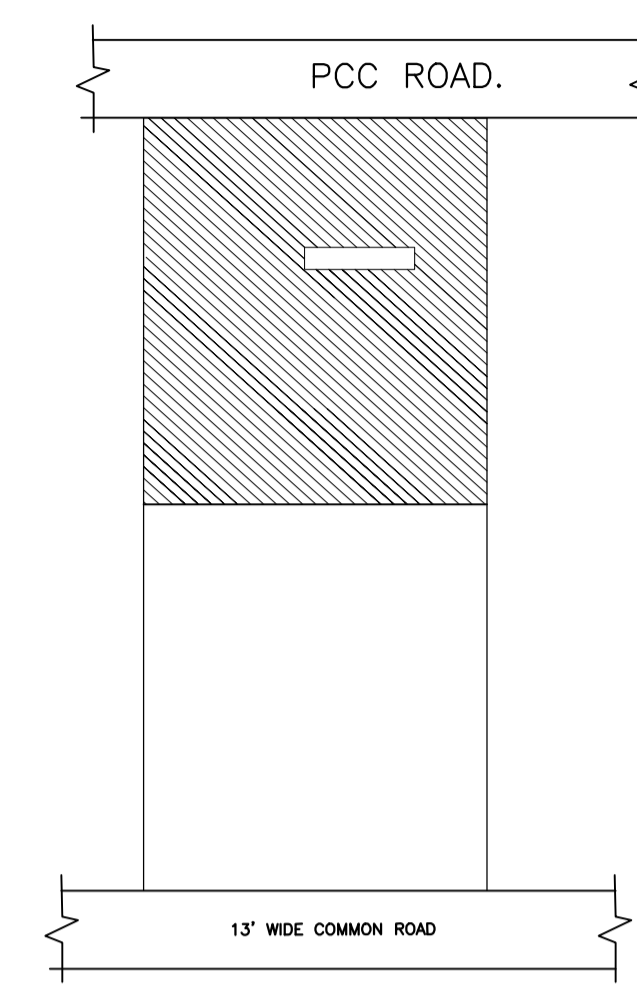

KEY PLAN
SCALE :- 1:100

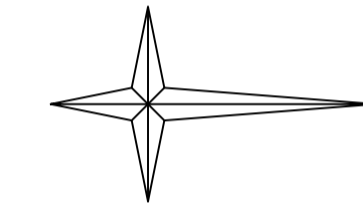

Proposal Basic Information	
Proposal File No.	MNP/BP/0030/W18/2021
Owner Name	FULKUMARI DEVI
Khata No	221
Plot No	814
Village Name	Patharchptti
Use	Residential
SubUse	Bungalow/ Dwelling / Non Apartment

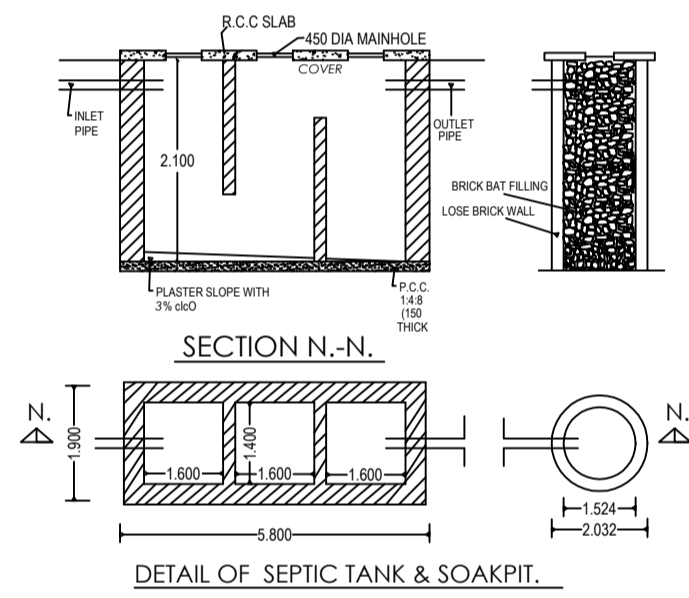

DETAIL OF SEPTIC TANK & SOAKPIT.

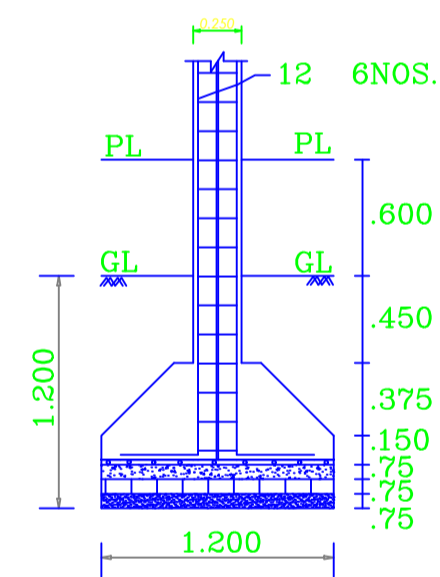

SECTION C-C

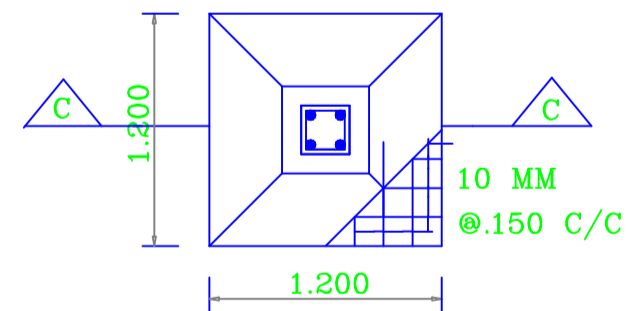

PLAN
R.C.C.COLUMN FOUNDN.
(SCALE- 1:50)

LTP NAME AND SIGNATURE	STRUCTURAL ENG'S NAME AND SIGNATURE	BUILDER NAME AND SIGNATURE	DIGITAL SIGNATURE
VISHAL YADAV MNP/ENG/0006/2020			