

Proposal Basic Information	
Proposal File No.	MNP/BP/0018/W21/2021
Owner Name	RAKIMA KHATOON
Khata No	59/78
Plot No	397
Village Name	Patharchptti
Use	Residential
SubUse	Bungalow/ Dwelling / Non Apartment

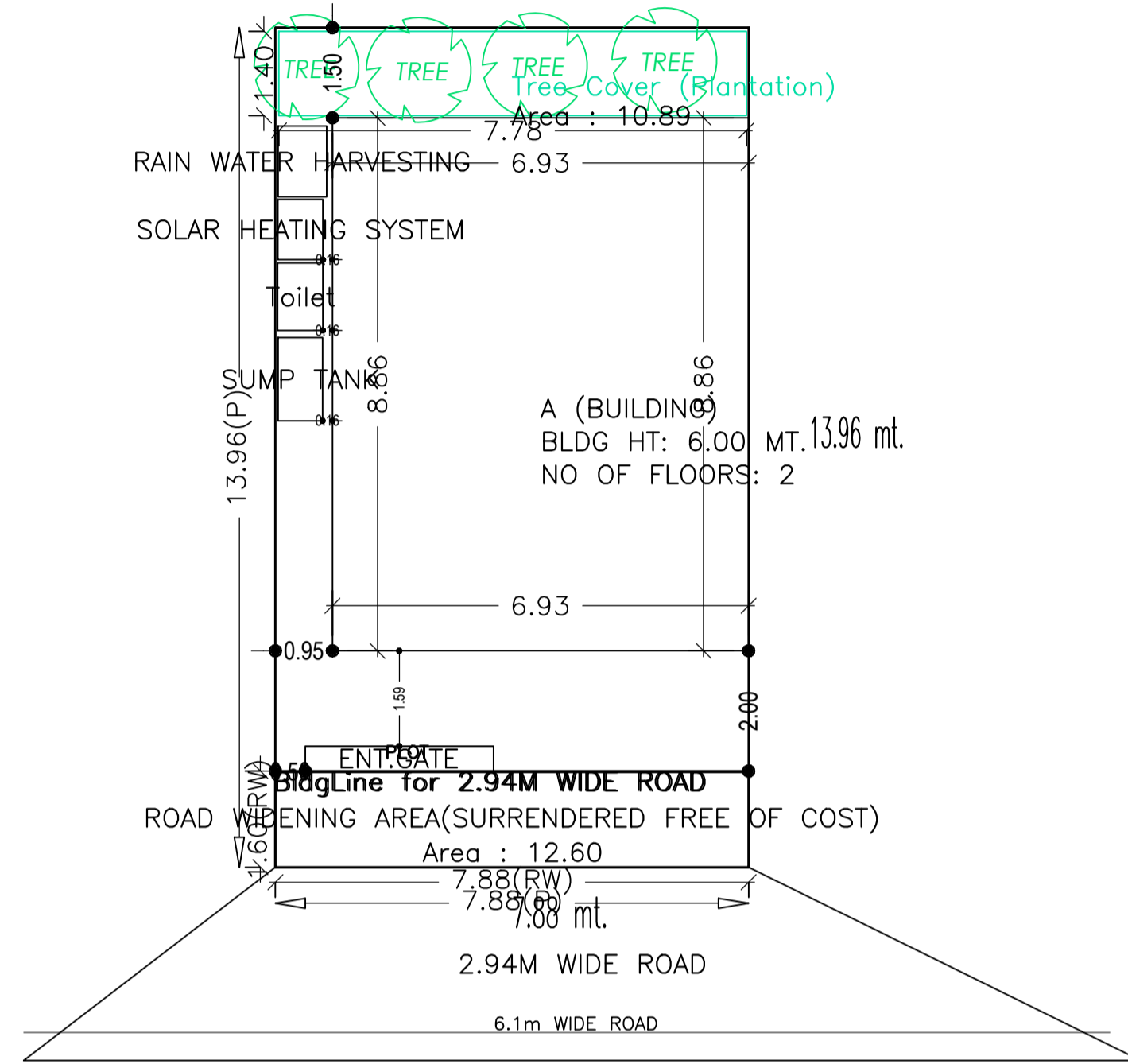

SITE PLAN

AREA STATEMENT		VERSION NO.: 1.0.55
MADHUPUR NAGAR PARISHAD		VERSION DATE: 16/10/2020
PROJECT DETAIL:		
Region - JHARKHAND URBAN LOCAL BODIES	Plot Use: Residential	
District: DEOGHAR	Plot SubUse: Bungalow/ Dwelling / Non Apartment	
Authority: MADHUPUR NAGAR PARISHAD	PlotNearby/ReligiousStructure: NA	
Inward No: MNP/BP/0018/W21/2021	Plot/SubPlot No: 397	
Application Type: General Proposal	North: Plot No. - VENDORS LAND	
Project Type: Building Permission	South: Road Width - 16.2	
Nature of Development: New	East: Plot No. - COMMON GALI	
Location of Development Area: Old Area	West: Plot No. - HOUSE OF SAMYUDDIN	
AREA DETAILS:		
AREA OF PLOT (Minimum)	(A)	SQ.MT. 109.98
Deduction for NetPlot Area		
Surrender Free of Cost		12.60
Total		12.60
NET AREA OF PLOT(Gross Plot Area - Deduction from Gross Plot area)	(A-Deductions)	97.38
Deduction for Balance Plot Area(from Gross Plot Area)		
Surrender Free of Cost		12.60
Common Plot		10.89
Total		23.49
BALANCE AREA OF PLOT(Net Plot Area - Recreational/Amenity space)	(A-Deductions)	86.49
PLOT AREA FOR COVERAGE(Net Plot Area)	(A-Deductions)	97.38
Plot Area for FAR (Net Plot Area + RoadWidening Area)	(A-Deductions)	109.98
COVERAGE CHECK		
Permissible Coverage area ( 70.00 % )		68.17
Proposed Coverage Area ( 63.04 % )		61.39
Total Prop. Coverage Area ( 63.04 % )		61.39
Balance coverage area ( 6.96 % )		6.78
FAR CHECK		
Perm. FAR Area ( 1.20 )		131.98
Total Perm. FAR area		131.98
Residential FAR		122.78
Proposed FAR Area		122.78
Total Proposed FAR Area		122.78
Consumed FAR (Factor)		1.12
Balance FAR Area		9.20
BUILT UP AREA CHECK		
Total Proposed BuiltUp Area		122.78
ARCHITECT (Regd)	VISHAL YADAV	
ENGINEER (Regd)		
SUPERVISOR (Regd)		
OWNER (Regd)	RAKIMA KHATOON	
DEVELOPMENT AUTHORITY		LOCAL BODY

Building USE/SUBUSE Details

Building Name	Building Use	Building SubUse	Building Structure
A (BUILDING)	Residential	Bungalow/ Dwelling / Non Apartment	Non-Highrise

FAR & Tenement Details (Table 4c-1)

Building	No. of Same Bldg	Total Built Up Area (Sq.mt.)	Proposed FAR Area (Sq.mt.) Resi.	Total FAR Area (Sq.mt.)	Total Consumed Additional FAR Area (Sq.mt.)	Tnmt (No.)
A (BUILDING)	1	122.78	122.78	122.78	122.78	01
Grand Total :	1	122.78	122.78	122.78	122.78	01

Buildingwise Floor FAR Details

Floor Name	Building Name A (BUILDING)		Total	
	Proposed Built Up Area (Sq.mt.)	Proposed FAR Area (Sq.mt.)	Total Proposed Built Up Area (Sq.mt.)	Total FAR Area (Sq.mt.)
Ground Floor	61.39	61.39	61.39	61.39
First Floor	61.39	61.39	61.39	61.39
Terrace Floor	0.00	0.00	0.00	0.00
Total :	122.78	122.78	122.78	122.78

COLOR INDEX	
PLOT BOUNDARY	[Red Line]
ABUTTING ROAD	[Green Line]
PROPOSED CONSTRUCTION	[Blue Line]
COMMON PLOT	[Yellow Line]
ROAD WIDENING AREA	[Orange Line]
EXISTING (To be retained)	[Purple Line]
EXISTING (To be demolished)	[Light Blue Line]

LTP NAME AND SIGNATURE	STRUCTURAL ENG'S NAME AND SIGNATURE	BUILDER NAME AND SIGNATURE	DIGITAL SIGNATURE
VISHAL YADAV MNP/ENG/0006/2020			

Proposal Basic Information

Proposal File No.	MNP/BP/0018/W21/2021
Owner Name	RAKIMA KHATOON
Khata No	59/78
Plot No	397
Village Name	Patharchptti
Use	Residential
SubUse	Bungalow/ Dwelling / Non Apartment

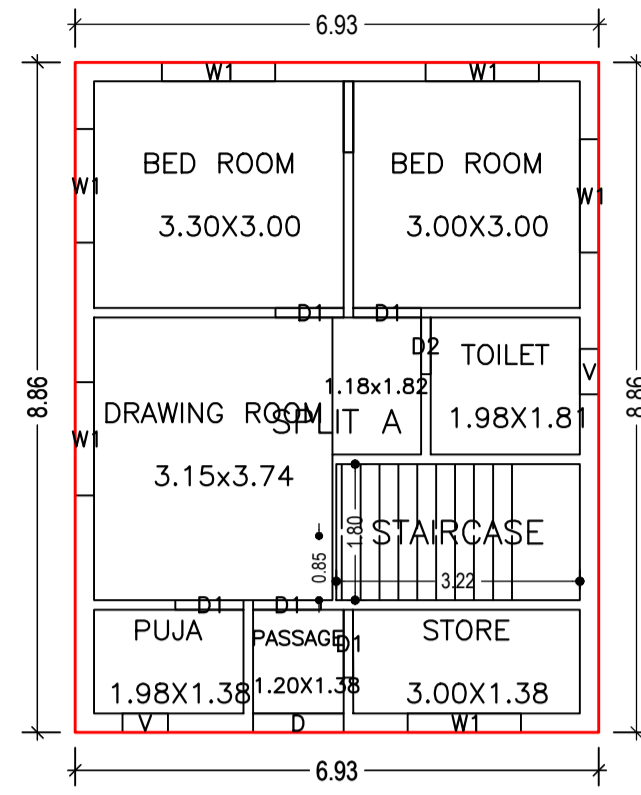

GROUND FLOOR PLAN  
(Proposed)  
(SCALE 1:100)

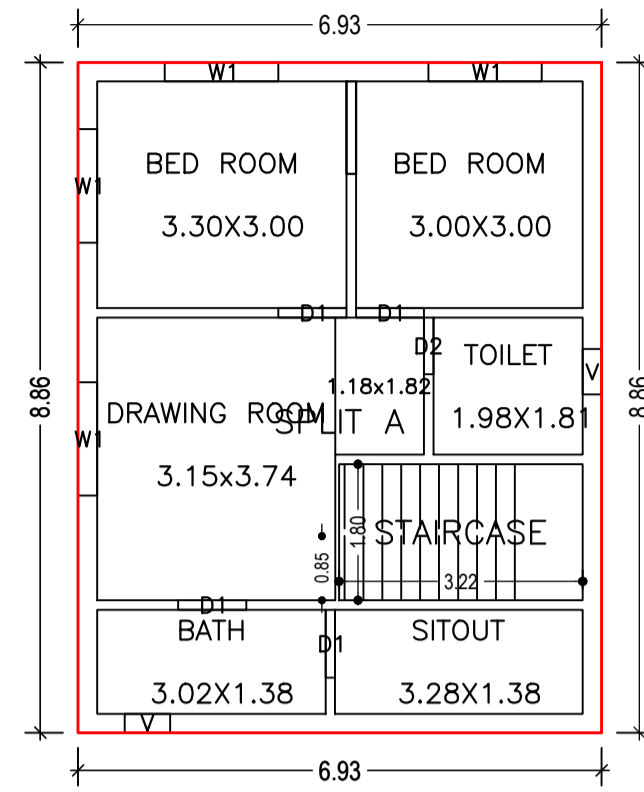

FIRST FLOOR PLAN  
(Proposed)  
(SCALE 1:100)

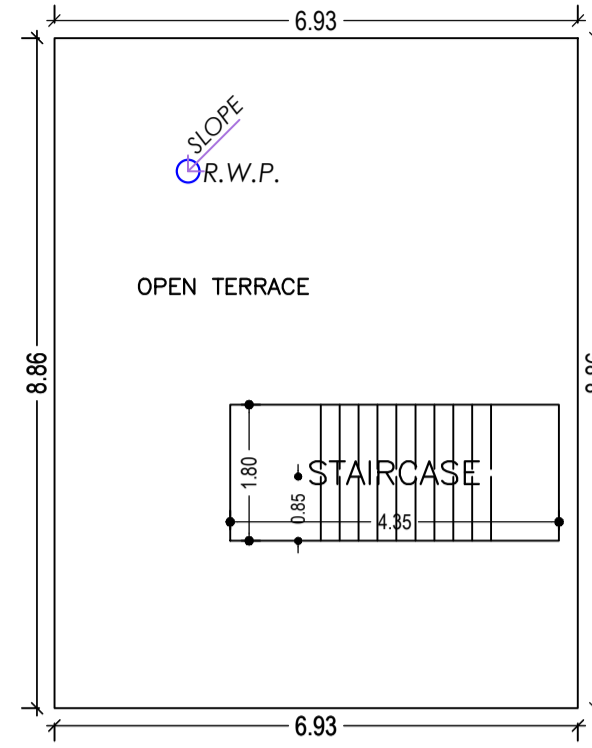

TERRACE FLOOR PLAN  
(Proposed)  
(SCALE 1:100)

UnitBUA Table for Building :A (BUILDING)

FLOOR	Name	UnitBUA Type	UnitBUA Area	Carpet Area	No. of Rooms	No. of Tenement
GROUND FLOOR PLAN	SPLIT A	FLAT	94.06	93.79	7	1
FIRST FLOOR PLAN	SPLIT A	FLAT	0.00	0.00	6	0
Total:	-	-	94.06	93.79	13	1

SCHEDULE OF DOOR:

BUILDING NAME	NAME	LENGTH	HEIGHT	NOS
A (BUILDING)	D2	0.75	2.10	02
A (BUILDING)	D1	0.90	2.10	09
A (BUILDING)	D	1.20	2.10	01

SCHEDULE OF WINDOW/VENTILATION:

BUILDING NAME	NAME	LENGTH	HEIGHT	NOS
A (BUILDING)	V	0.60	0.60	02
A (BUILDING)	V	0.60	1.20	02
A (BUILDING)	W1	1.50	1.20	10

Building :A (BUILDING)

Floor Name	Total Built Up Area (Sq.mt.)	Proposed FAR Area (Sq.mt.) Resi.	Total FAR Area (Sq.mt.)	Total Consumed Additional FAR Area (Sq.mt.)	Tnmt (No.)
Ground Floor	61.39	61.39	61.39	61.39	01
First Floor	61.39	61.39	61.39	61.39	00
Terrace Floor	0.00	0.00	0.00	0.00	00
Total :	122.78	122.78	122.78	122.78	01
Total Number of Same Buildings :	1				
Total :	122.78	122.78	122.78	122.78	01

LTP NAME AND SIGNATURE	STRUCTURAL ENG'S NAME AND SIGNATURE	BUILDER NAME AND SIGNATURE	DIGITAL SIGNATURE
VISHAL YADAV MNP/ENG/0006/2020			

Proposal Basic Information	
Proposal File No.	MNP/BP/0018/W21/2021
Owner Name	RAKIMA KHATOON
Khata No	59/78
Plot No	397
Village Name	Patharchptti
Use	Residential
SubUse	Bungalow/ Dwelling / Non Apartment



**FRONT ELEVATION**  
SCALE :- 1:100

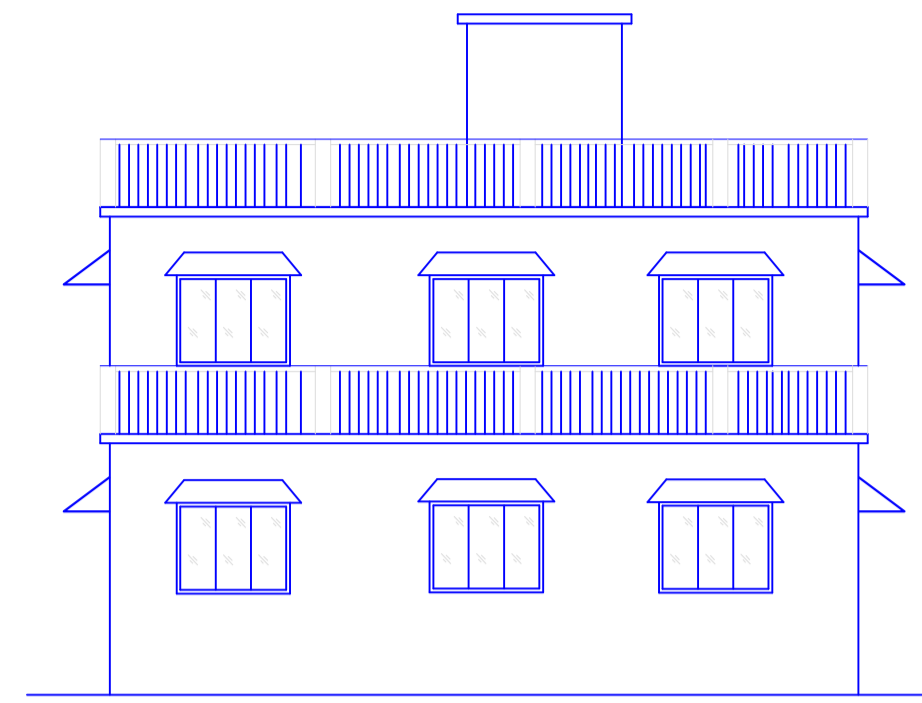

**RIGHT SIDE ELEVATION**  
SCALE :- 1:100

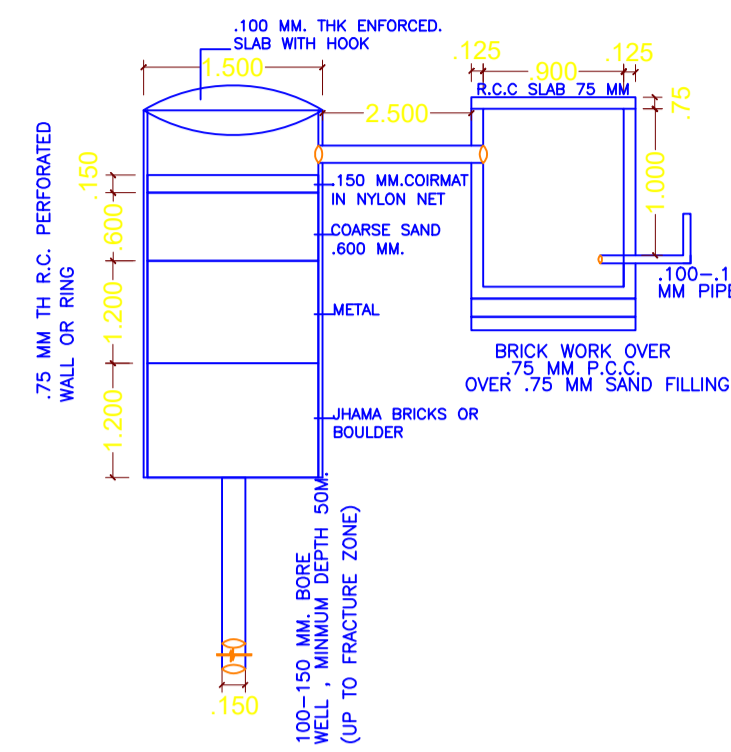

**DETAIL OF GROUND WATER RECHARGING PIT WITH SLIT TANK**  
(SCALE 1:50)

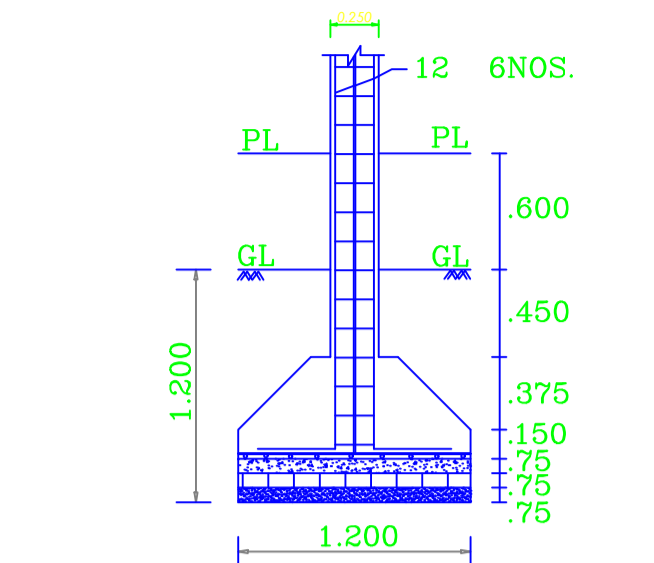

**SECTION C-C**

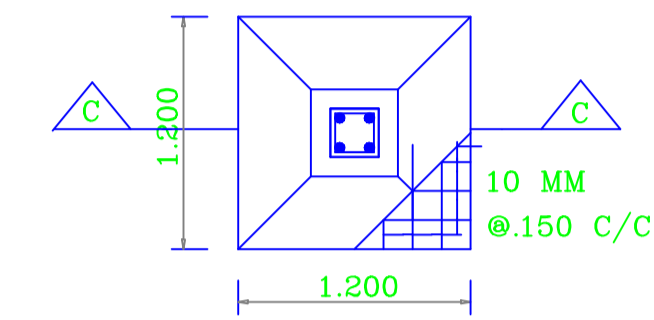

**PLAN**  
**R.C.C.COLUMN FOUNDN.**  
(SCALE- 1:50)

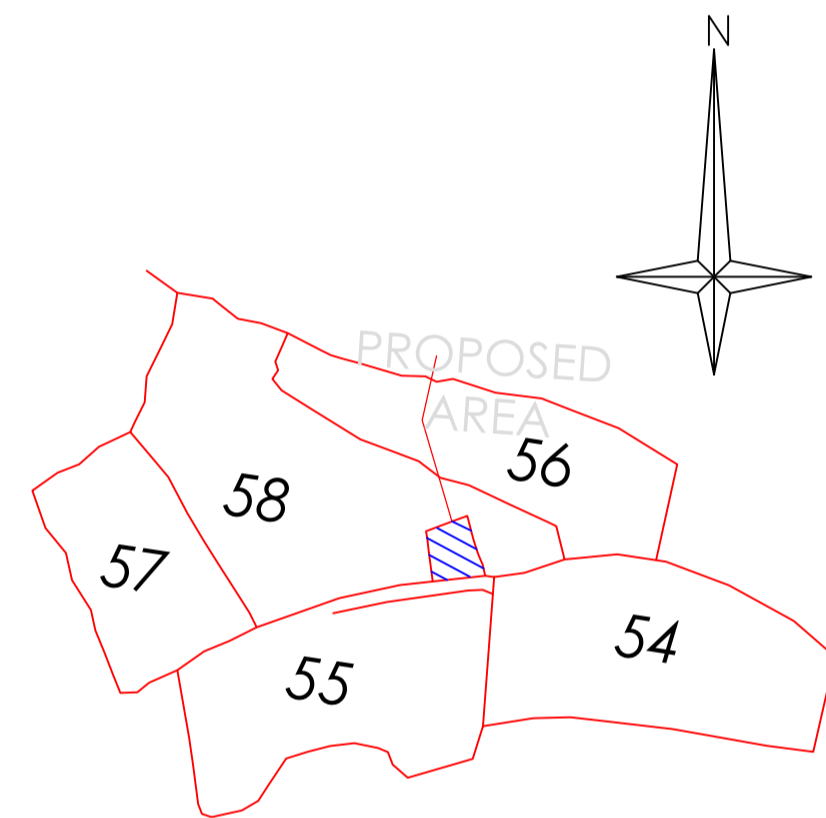

**KEY PLAN**  
SCALE :- N.T.S.

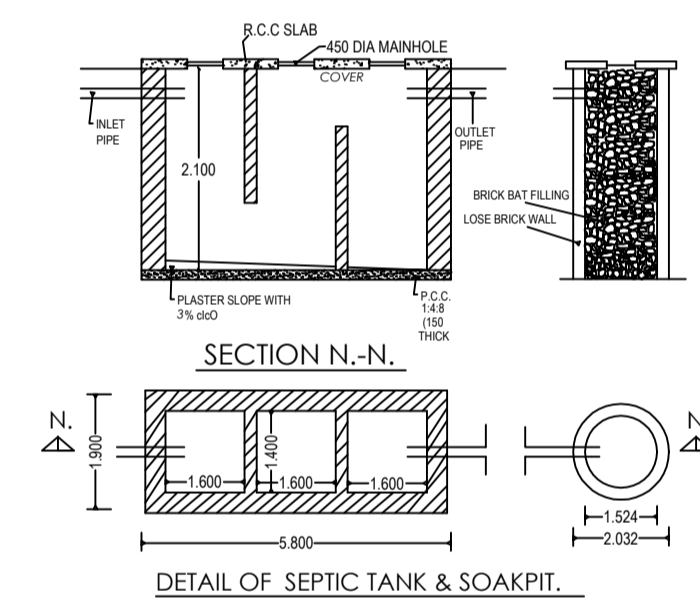

**SECTION N-N.**  
**DETAIL OF SEPTIC TANK & SOAKPIT.**

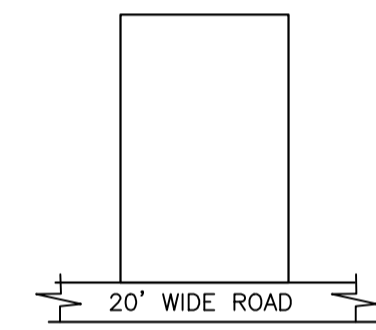

**LOCATION PLAN**  
SCALE :- 1:100

LTP NAME AND SIGNATURE	STRUCTURAL ENG'S NAME AND SIGNATURE	BUILDER NAME AND SIGNATURE	DIGITAL SIGNATURE
VISHAL YADAV MNP/ENG/0006/2020			