

Proposal Basic Information	
Proposal File No.	MNP/BP/0063/W06/2021
Owner Name	SONY ALIAS SHAHEEN PRAWEEEN
Khata No	3/1
Plot No	3
Village Name	Patharchptti
Use	Residential
SubUse	Bungalow/ Dwelling / Non Apartment

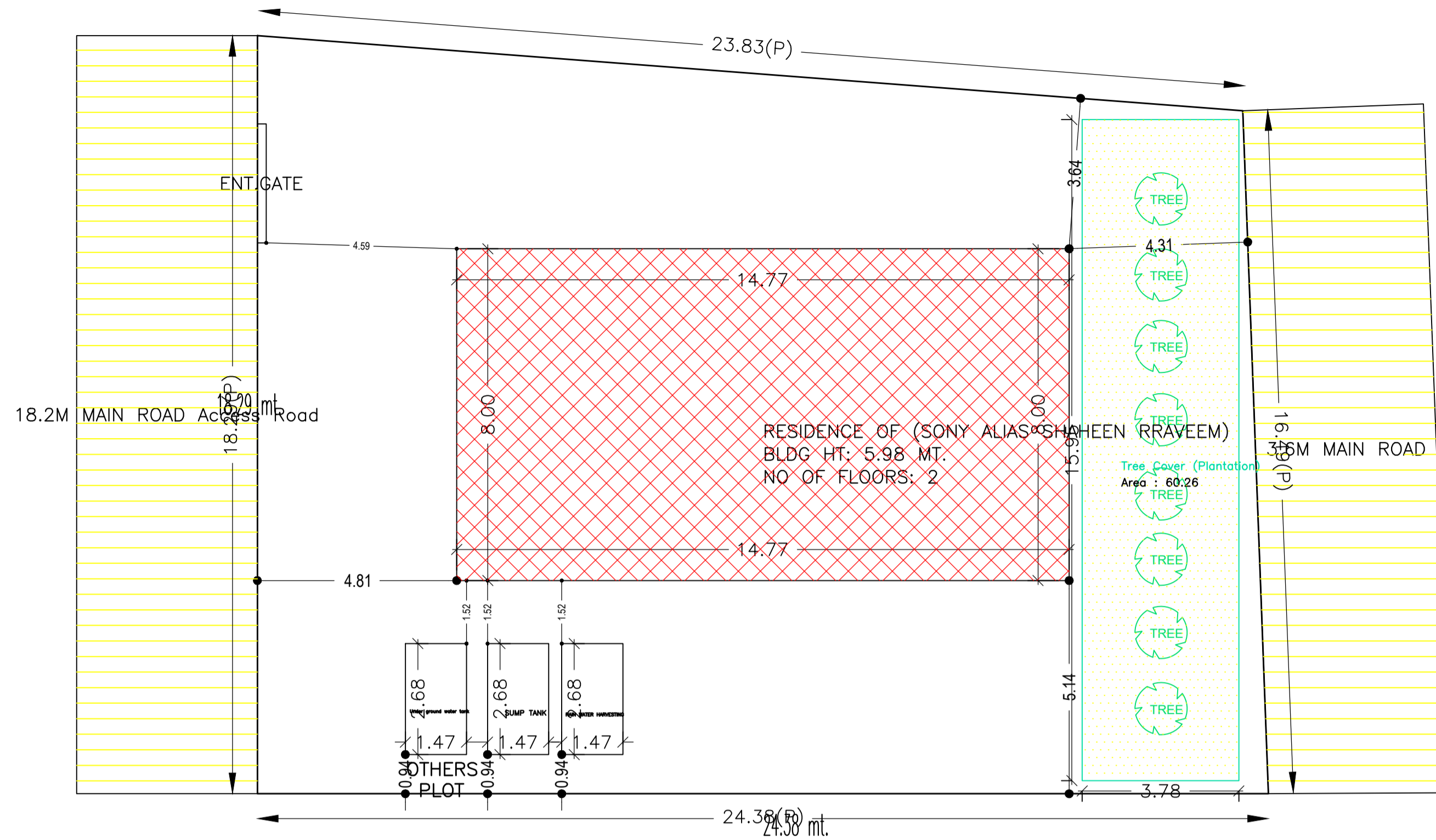

Buildingwise Floor FAR Details

Floor Name	Building Name RESIDENCE OF (SONY ALIAS SHAHEEN RRAVEEM)		Total	
	Proposed Built Up Area (Sq.mt.)	Proposed FAR Area (Sq.mt.)	Total Proposed Built Up Area (Sq.mt.)	Total FAR Area (Sq.mt.)
Ground Floor	118.22	118.22	118.22	118.22
First Floor	159.22	138.72	159.22	138.72
Terrace Floor	0.00	0.00	0.00	0.00
Total :	277.44	256.94	277.44	256.94

Building USE/SUBUSE Details

Building Name	Building Use	Building SubUse	Building Structure
RESIDENCE OF (SONY ALIAS SHAHEEN RRAVEEM)	Residential	Bungalow/ Dwelling / Non Apartment	Non-Highrise

FAR & Tenement Details (Table 4c-1)

Building	No. of Same Bldg	Total Built Up Area (Sq.mt.)	Deductions (Area in Sq.mt.)		Proposed FAR Area (Sq.mt.)	Total FAR Area (Sq.mt.)	Total Consumed Additional FAR Area (Sq.mt.)	Tnmt (No.)
			Balcony	Resi.				
RESIDENCE OF (SONY ALIAS SHAHEEN RRAVEEM)	1	277.44	20.50		256.94	256.94	256.94	01
Grand Total :	1	277.44	20.50		256.94	256.94	256.94	01

SITE PLAN

COLOR INDEX	
PLOT BOUNDARY	Black
ABUTTING ROAD	Green
PROPOSED CONSTRUCTION	Red
COMMON PLOT	Yellow
ROAD WIDENING AREA	Blue
EXISTING (To be retained)	Light Blue
EXISTING (To be demolished)	Light Yellow

AREA STATEMENT		VERSION NO. : 1.0.64
MADHUPUR NAGAR PARISHAD		VERSION DATE: 16/10/2020
PROJECT DETAIL:		
Region : JHARKHAND URBAN LOCAL BODIES	Plot Use: Residential	
District: DEOGHAR	Plot SubUse: Bungalow/ Dwelling / Non Apartment	
Authority: MADHUPUR NAGAR PARISHAD	PlotNearby/ReligiousStructure: NA	
Inward No: MNP/BP/0063/W06/2021	Plot/SubPlot No: 3	
Application Type: General Proposal	North: Plot No. - OTHER'S PLOT	
Project Type: Building Permission	South: Plot No. - OTHER'S PLOT	
Nature of Development: New	East: Road Width - 12' wide road	
Location of Development Area: Old Area	West: Road Width - MUNICIPAL ROAD	
AREA DETAILS:		
AREA OF PLOT (Minimum)	(A)	418.17
NET AREA OF PLOT(Gross Plot Area - Deduction from Gross Plot area)	(A-Deductions)	418.17
Deduction for Balance Plot Area(from Gross Plot Area)		
Common Plot		60.26
Total		60.26
BALANCE AREA OF PLOT(Net Plot Area - Recreational/Amenity space)	(A-Deductions)	357.91
PLOT AREA FOR COVERAGE(Net Plot Area)	(A-Deductions)	418.17
Plot Area for FAR (Net Plot Area + RoadWidening Area)	(A-Deductions)	418.17
COVERAGE CHECK		
Permissible Coverage area (60.00 %)		250.90
Proposed Coverage Area (28.27 %)		118.22
Total Prop. Coverage Area (28.27 %)		118.22
Balance coverage area (31.73 %)		132.68
FAR CHECK		
Perm. FAR Area (2.000)		836.34
Total Perm. FAR area		836.34
Residential FAR		256.93
Proposed FAR Area		256.93
Total Proposed FAR Area		256.93
Consumed FAR (Factor)		0.61
Balance FAR Area		579.41
BUILT UP AREA CHECK		
Total Proposed BuiltUp Area		277.44
ARCHITECT (Regd)	MUKUND PRASAD SHAHI	
ENGINEER (Regd)		
SUPERVISOR (Regd)		
OWNER (Regd)	SONY ALIAS SHAHEEN PRAWEEEN	
DEVELOPMENT AUTHORITY		LOCAL BODY

LTP NAME AND SIGNATURE	STRUCTURAL ENG'S NAME AND SIGNATURE	BUILDER NAME AND SIGNATURE	DIGITAL SIGNATURE
MUKUND PRASAD SHAHI MNP/ENG/0005/2017			

Proposal Basic Information

Proposal File No.	MNP/BP/0063/W06/2021
Owner Name	SONY ALIAS SHAHEEN PRAWEEN
Khata No	3/1
Plot No	3
Village Name	Patharchptti
Use	Residential
SubUse	Bungalow/ Dwelling / Non Apartment

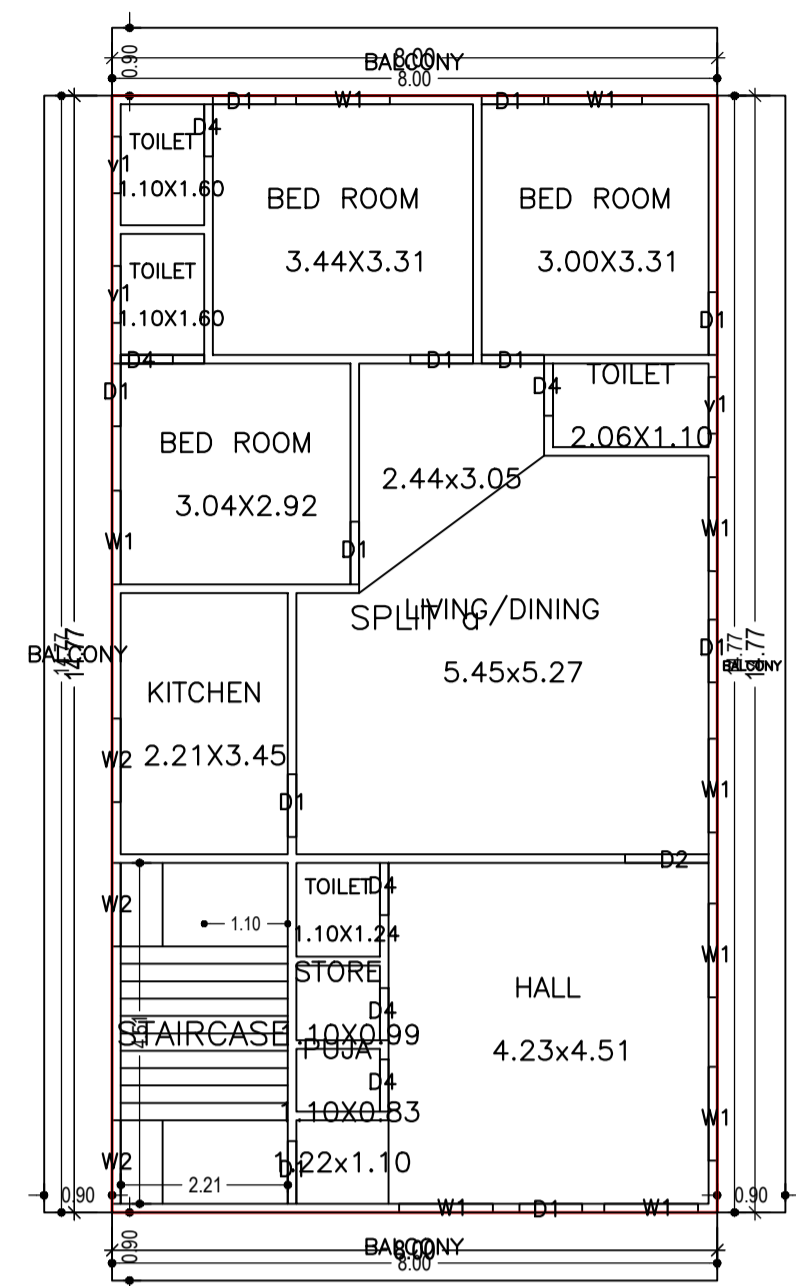

FIRST FLOOR PLAN
(Proposed)
(SCALE 1:100)

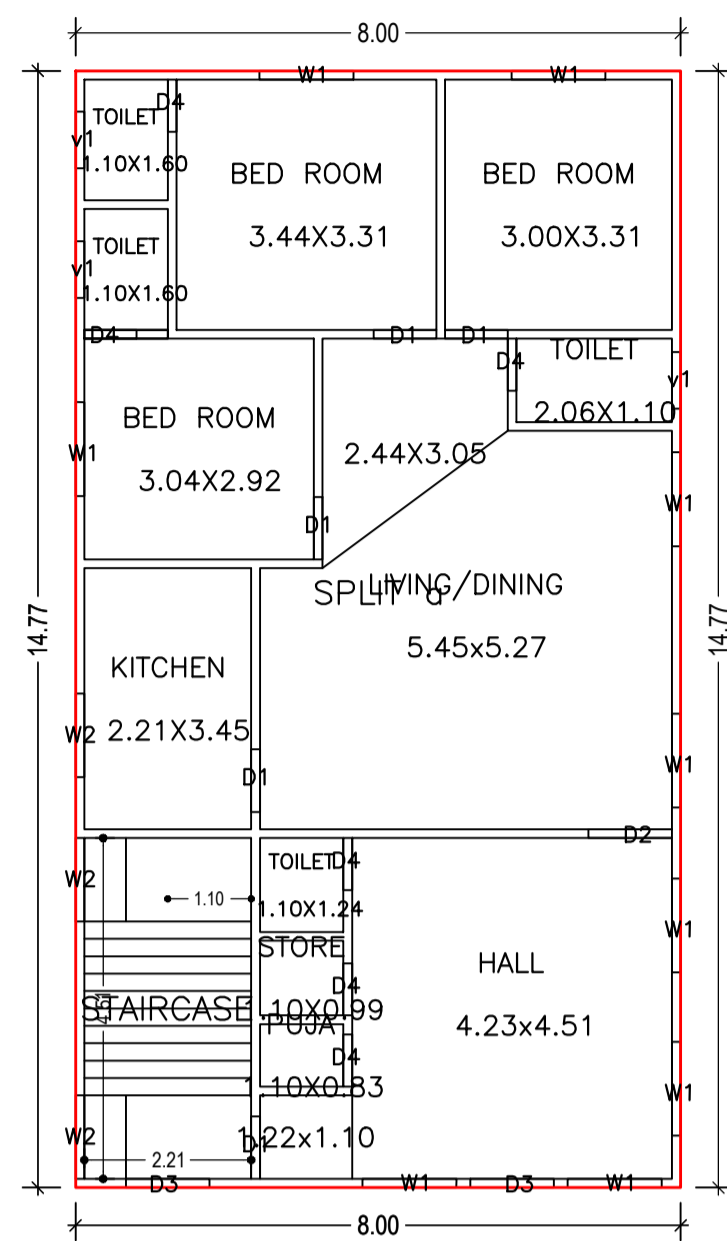

GROUND FLOOR PLAN
(Proposed)
(SCALE 1:100)

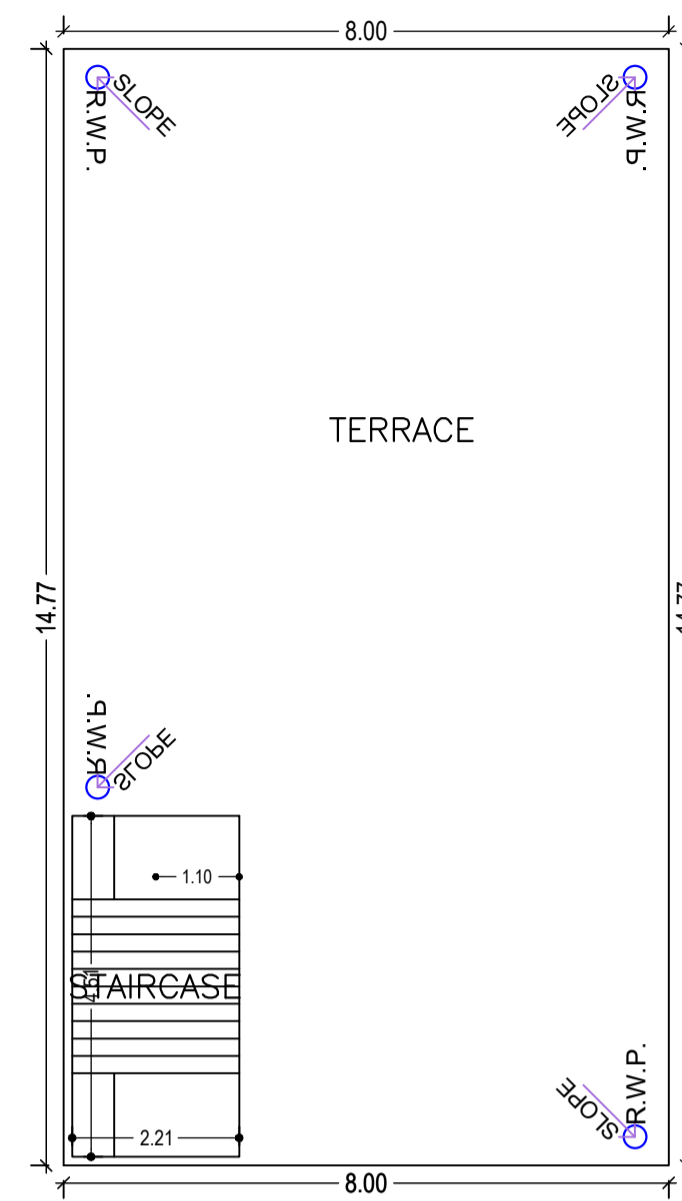

TERRACE FLOOR PLAN
(SCALE 1:100)

Balcony Calculations Table

FLOOR	SIZE	AREA	TOTAL AREA
FIRST FLOOR PLAN	0.90 X 8.00 X 2 X 1	14.40	40.98
	0.90 X 14.77 X 2 X 1	26.58	
Total	-	-	40.98

UnitBUA Table for Building :RESIDENCE OF (SONY ALIAS SHAHEEN RRAVEEM)

FLOOR	Name	UnitBUA Type	UnitBUA Area	Carpet Area	No. of Rooms	No. of Tenement
FIRST FLOOR PLAN	SPLIT a	FLAT	0.00	0.00	12	0
GROUND FLOOR PLAN	SPLIT a	FLAT	226.07	225.81	12	1
Total:	-	-	226.07	225.81	24	1

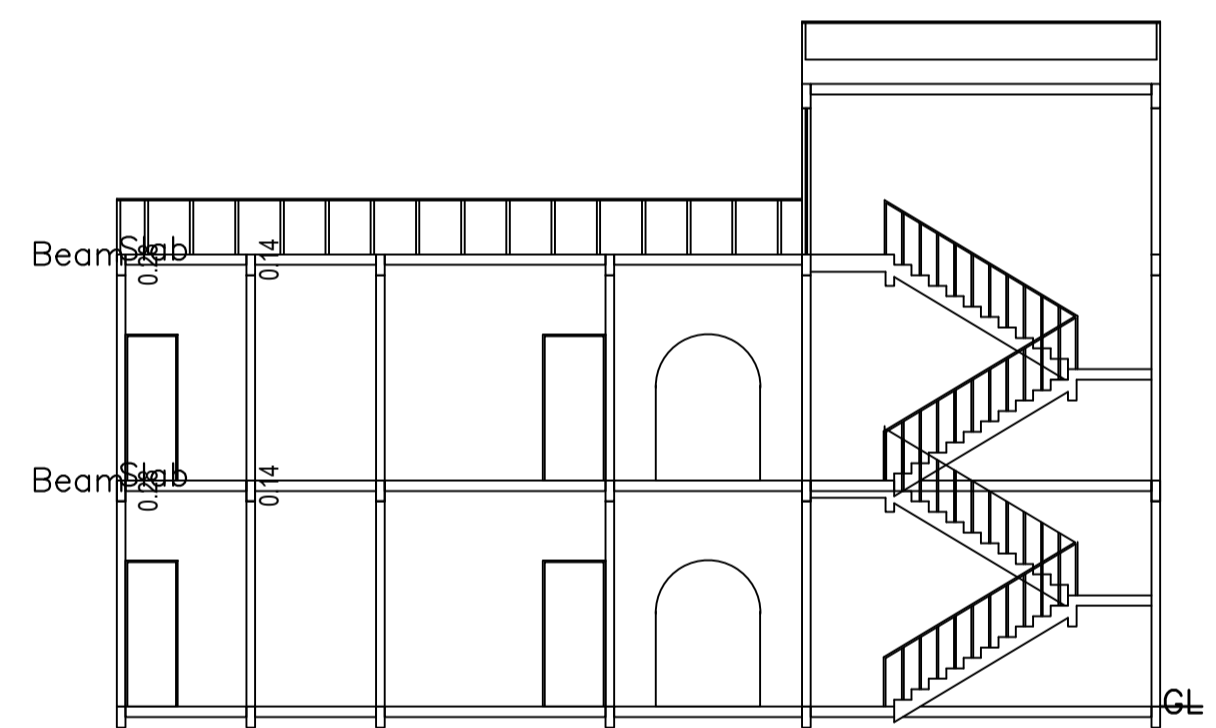
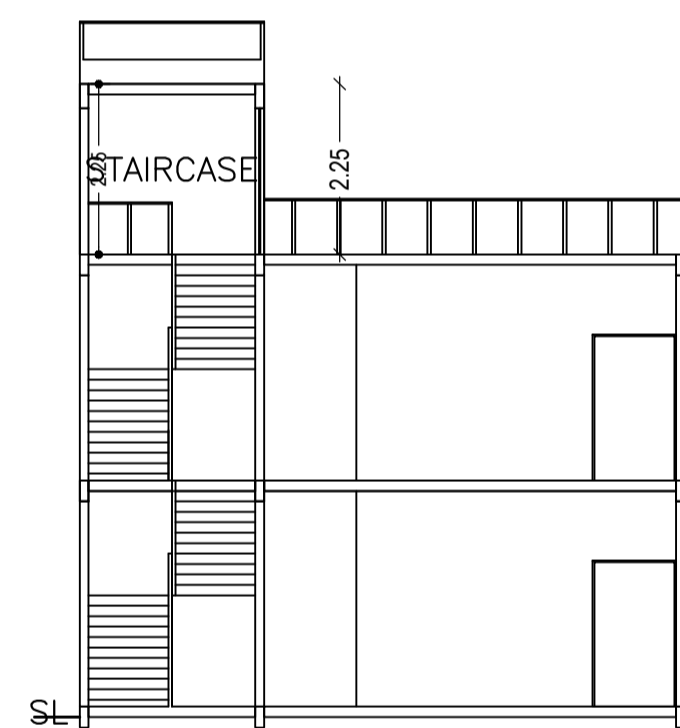

SCHEDULE OF DOOR:

BUILDING NAME	NAME	LENGTH	HEIGHT	NOS
RESIDENCE OF (SONY ALIAS SHAHEEN RRAVEEM)	D4	0.69	2.13	12
RESIDENCE OF (SONY ALIAS SHAHEEN RRAVEEM)	D1	0.83	2.13	16
RESIDENCE OF (SONY ALIAS SHAHEEN RRAVEEM)	D2	1.10	2.13	02
RESIDENCE OF (SONY ALIAS SHAHEEN RRAVEEM)	D3	1.10	2.13	01

SCHEDULE OF WINDOW/VENTILATION:

BUILDING NAME	NAME	LENGTH	HEIGHT	NOS
RESIDENCE OF (SONY ALIAS SHAHEEN RRAVEEM)	v1	0.75	2.70	06
RESIDENCE OF (SONY ALIAS SHAHEEN RRAVEEM)	W2	1.10	2.70	06
RESIDENCE OF (SONY ALIAS SHAHEEN RRAVEEM)	W1	1.24	2.70	18

Building :RESIDENCE OF (SONY ALIAS SHAHEEN RRAVEEM)

Floor Name	Total Built Up Area (Sq.mt.)	Deductions (Area in Sq.mt.) Balcony	Proposed FAR Area (Sq.mt.) Resi.	Total FAR Area (Sq.mt.)	Total Consumed Additional FAR Area (Sq.mt.)	Tnmt (No.)
Ground Floor	118.22	0.00	118.22	118.22	118.22	01
First Floor	159.22	20.50	138.72	138.72	138.72	00
Terrace Floor	0.00	0.00	0.00	0.00	0.00	00
Total :	277.44	20.50	256.94	256.94	256.94	01
Total Number of Same Buildings :	1					
Total :	277.44	20.50	256.94	256.94	256.94	01

LTP NAME AND SIGNATURE	STRUCTURAL ENG'S NAME AND SIGNATURE	BUILDER NAME AND SIGNATURE	DIGITAL SIGNATURE
MUKUND PRASAD SHAHI MNP/ENG/0005/2017			

Proposal Basic Information

Proposal File No.	MNP/BP/0063/W06/2021
Owner Name	SONY ALIAS SHAHEEN PRAWEEEN
Khata No	3/1
Plot No	3
Village Name	Patharchptti
Use	Residential
SubUse	Bungalow/ Dwelling / Non Apartment

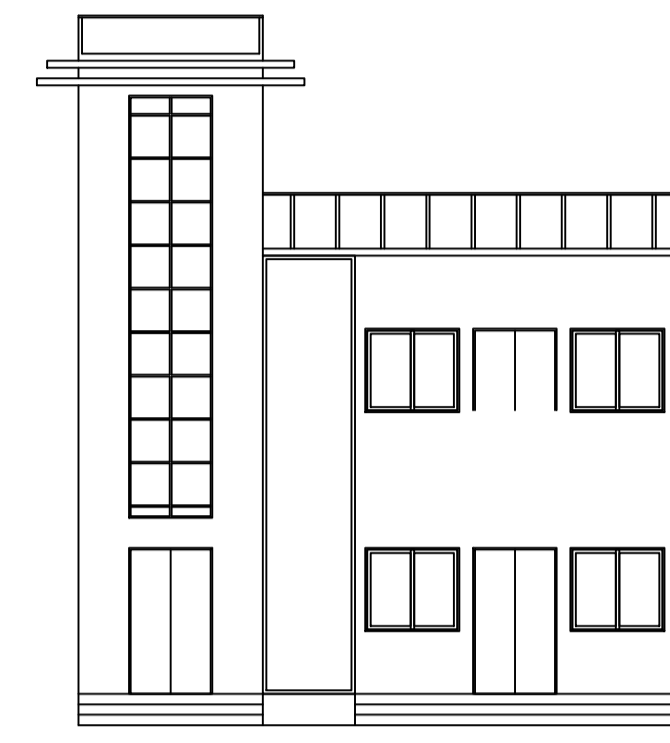
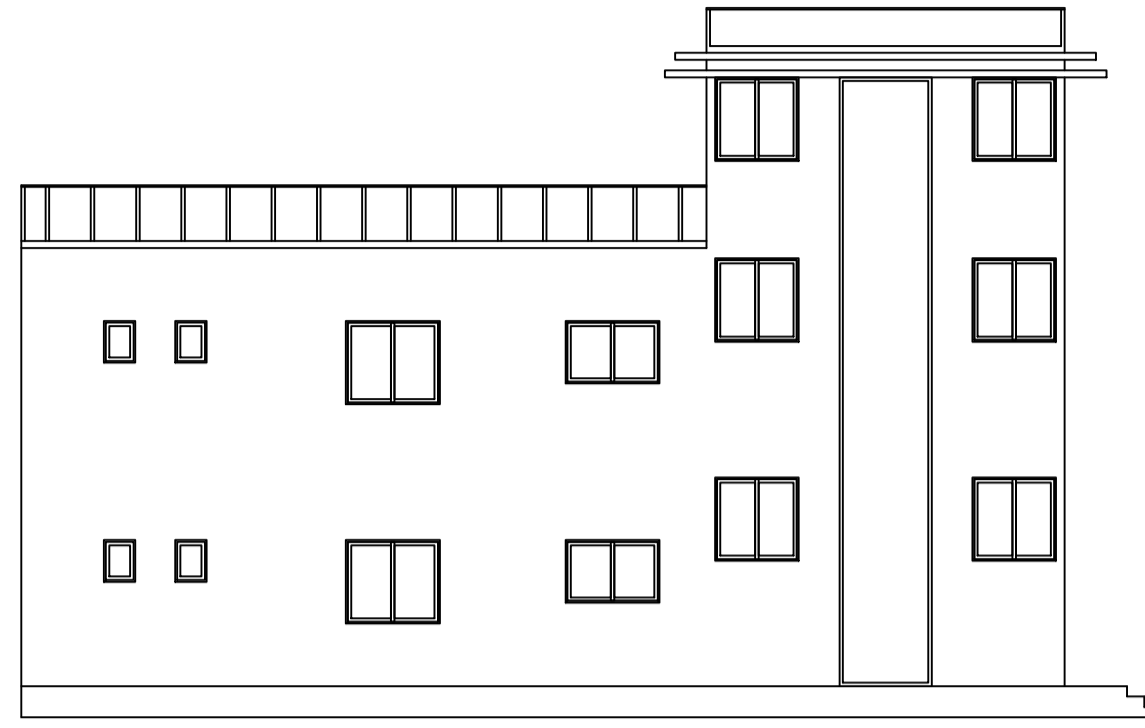
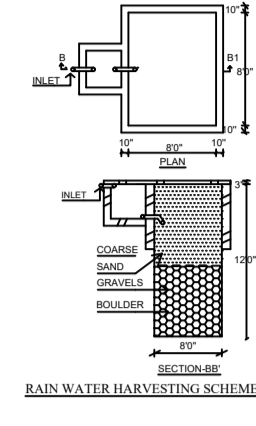
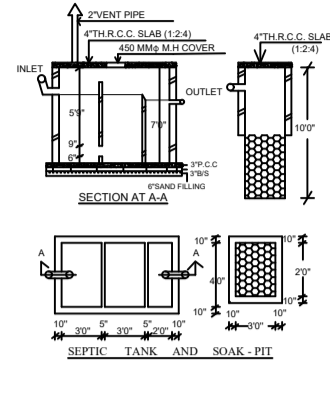
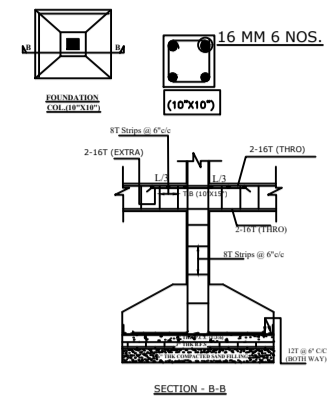

LTP NAME AND SIGNATURE	STRUCTURAL ENG'S NAME AND SIGNATURE	BUILDER NAME AND SIGNATURE	DIGITAL SIGNATURE
MUKUND PRASAD SHAHI MNP/ENG/0005/2017			