

Project Title : Project Title : Proposed Residential Building Plan For Bishnu Prasad Tibrewal

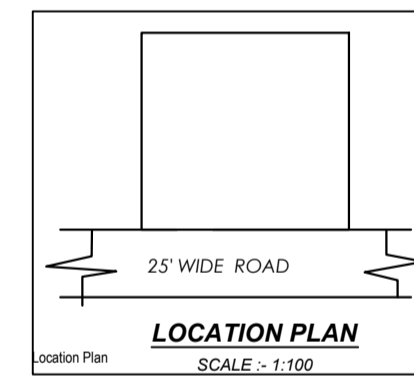
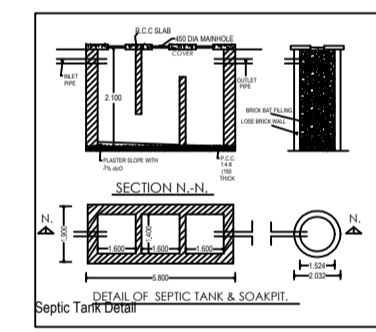
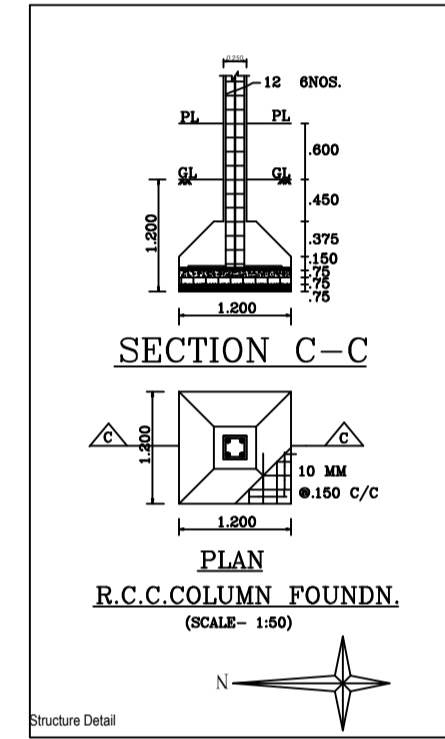
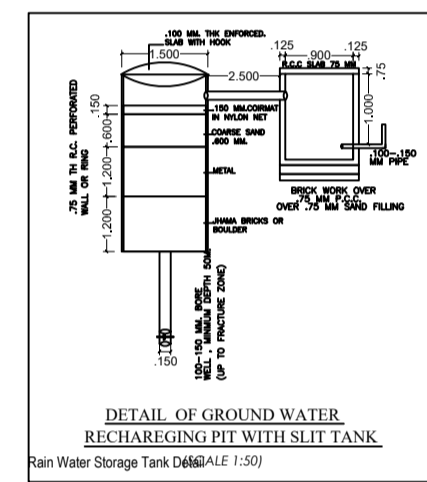
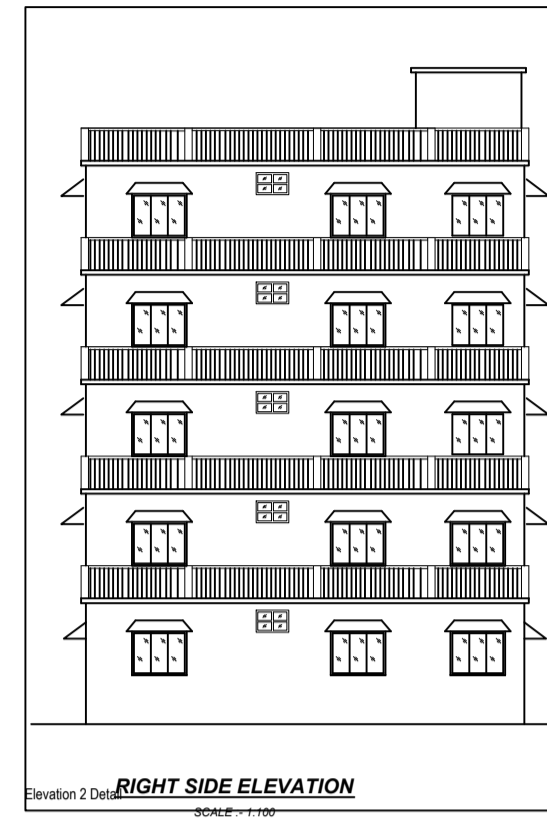
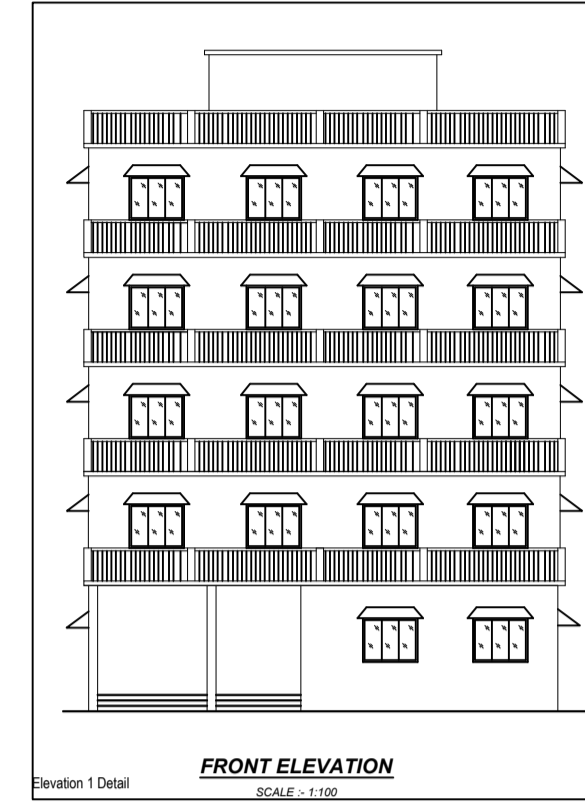
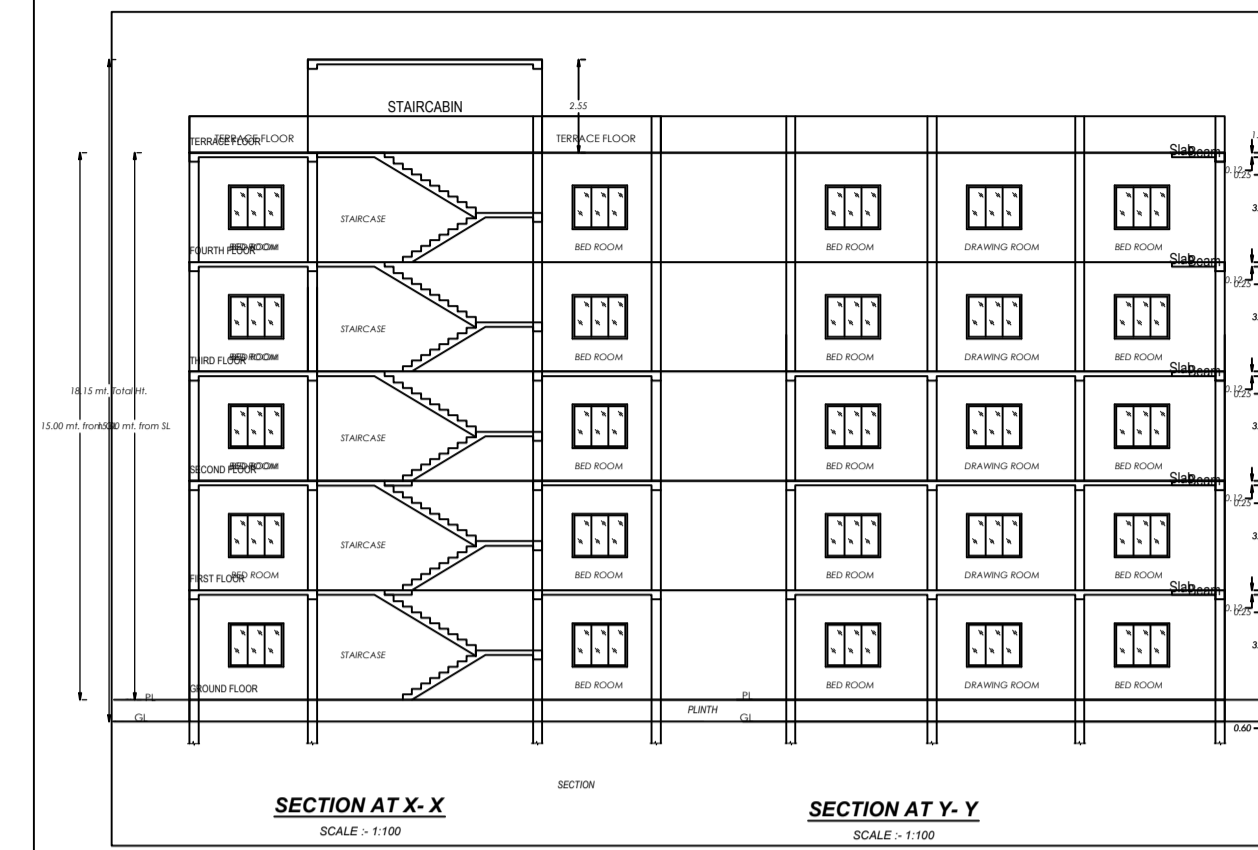

SPECIFICATION

- 1. All work shall be done in accordance with the specifications given in the schedule of materials and workmanship.
- 2. All work shall be done in accordance with the specifications given in the schedule of materials and workmanship.
- 3. All work shall be done in accordance with the specifications given in the schedule of materials and workmanship.
- 4. All work shall be done in accordance with the specifications given in the schedule of materials and workmanship.
- 5. All work shall be done in accordance with the specifications given in the schedule of materials and workmanship.
- 6. All work shall be done in accordance with the specifications given in the schedule of materials and workmanship.
- 7. All work shall be done in accordance with the specifications given in the schedule of materials and workmanship.
- 8. All work shall be done in accordance with the specifications given in the schedule of materials and workmanship.
- 9. All work shall be done in accordance with the specifications given in the schedule of materials and workmanship.
- 10. All work shall be done in accordance with the specifications given in the schedule of materials and workmanship.

S.No.	ITEM	TYPE	WIDTH	DEPTH	HEIGHT	DESCRIPTION
1.	DOORS	1.	1.00	2.00	2.00	WOODEN DOOR WITH GLASS
2.	WINDOWS	1.	1.00	1.50	1.50	WOODEN WINDOW WITH GLASS
3.	VENTILATORS	1.	0.80	0.80	1.00	WOODEN VENTILATOR WITH GLASS

AREA STATEMENT

AREA STATEMENT

AREA OF GROUND FLOOR - 160.44 SMT.

AREA OF FIRST FLOOR - 160.44 SMT.

AREA OF SECOND FLOOR - 160.44 SMT.

TOTAL BUILT UP AREA - 481.32 SMT.

% sq. OF COVERED AREA - 55.75%

TOTAL F.A.R. ACHIEVED - 0.9

PROPOSED RESIDENTIAL BUILDING OF M/s BISHNU PRASAD TIBREWAL, S/O. RADHESHYAM TIBREWAL, AT VILLAGE-PANCH MANDIR ROAD MADHUPUR, R.S. PLOT NO-01, KHATA NO -05, THANA NO-272, THANA -MADHUPUR, DISTT. -DEOGHAR, JHARKHAND-815353

APPLICANT SIGNATURE _____ ENGG. SIGNATURE _____

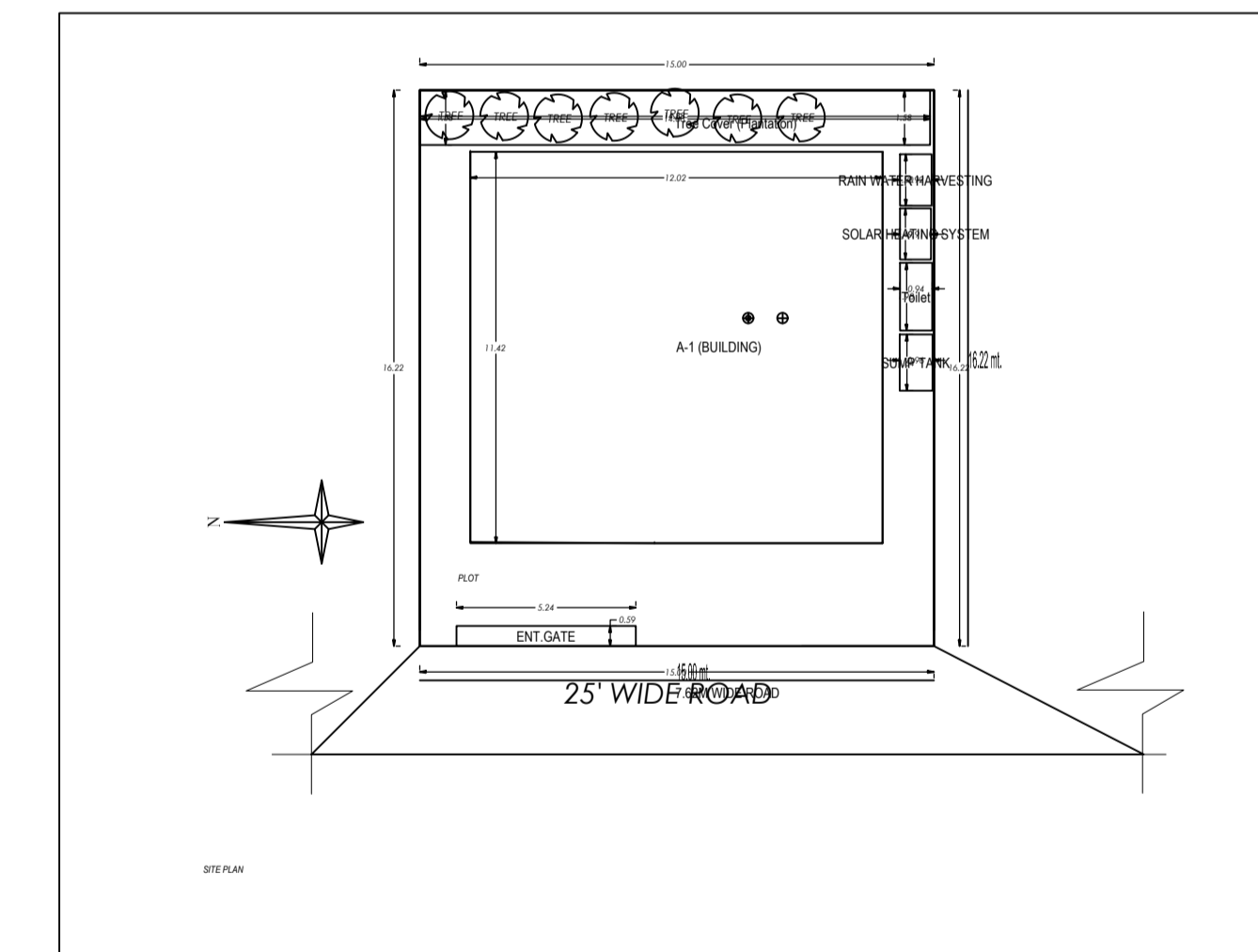

AREA STATEMENT

Sl. No.	Particulars	Area (SMT.)
1.	Plot Area	862.31
2.	Area of Ground Floor	160.44
3.	Area of First Floor	160.44
4.	Area of Second Floor	160.44
5.	Total Built Up Area	481.32
6.	% of Covered Area	55.75%
7.	Total F.A.R. Achieved	0.9

Color Index

Color	Description
White	Plaster
Red	Brickwork
Blue	Paint
Green	Paint
Black	Paint

Table with 10 columns: Building, No. of Storeys, Total Built Up Area (SMT.), Total Plotted Area (SMT.), Total Plotted Area (Sq. Ft.), Total Plotted Area (Acres), Total Plotted Area (Gaj), Total Plotted Area (Aana), Total Plotted Area (Bigha), Total Plotted Area (Mudra).

Building A (BUILDING)

Floor	Total Built Up Area (SMT.)	Total Plotted Area (SMT.)	Total Plotted Area (Sq. Ft.)	Total Plotted Area (Acres)	Total Plotted Area (Gaj)	Total Plotted Area (Aana)	Total Plotted Area (Bigha)	Total Plotted Area (Mudra)
Ground Floor	160.44	160.44	160.44	36.64	160.44	4.12	160.44	160.44
First Floor	160.44	160.44	160.44	36.64	160.44	4.12	160.44	160.44
Second Floor	160.44	160.44	160.44	36.64	160.44	4.12	160.44	160.44
Total	481.32	481.32	481.32	109.92	481.32	12.36	481.32	481.32

SCHEDULE OF JOINTS

Joint No.	Location	Description
1.	At Column <td>Vertical Joint</td>	Vertical Joint
2.	At Wall <td>Vertical Joint</td>	Vertical Joint
3.	At Slab <td>Horizontal Joint</td>	Horizontal Joint
4.	At Beam <td>Horizontal Joint</td>	Horizontal Joint
5.	At Terrace <td>Horizontal Joint</td>	Horizontal Joint

Useful Table for Building A (BUILDING)

Floor	Name	Useful Area (SMT.)	Useful Area (Sq. Ft.)	Useful Area (Acres)	No. of Rooms	% of Covered Area
Ground Floor	FLAT	160.44	160.44	36.64	1	55.75%
First Floor	FLAT	160.44	160.44	36.64	1	55.75%
Second Floor	FLAT	160.44	160.44	36.64	1	55.75%
Total		481.32	481.32	109.92	3	55.75%