

Proposal Basic Information	
Proposal File No.	MNP/BP/0040/W07/2021
Owner Name	BISHNU PRASAD TIBREWAL
Khata No	05
Plot No	0/1
Village Name	Bara Shekhpura
Use	Residential
SubUse	Bungalow/ Dwelling / Non Apartment

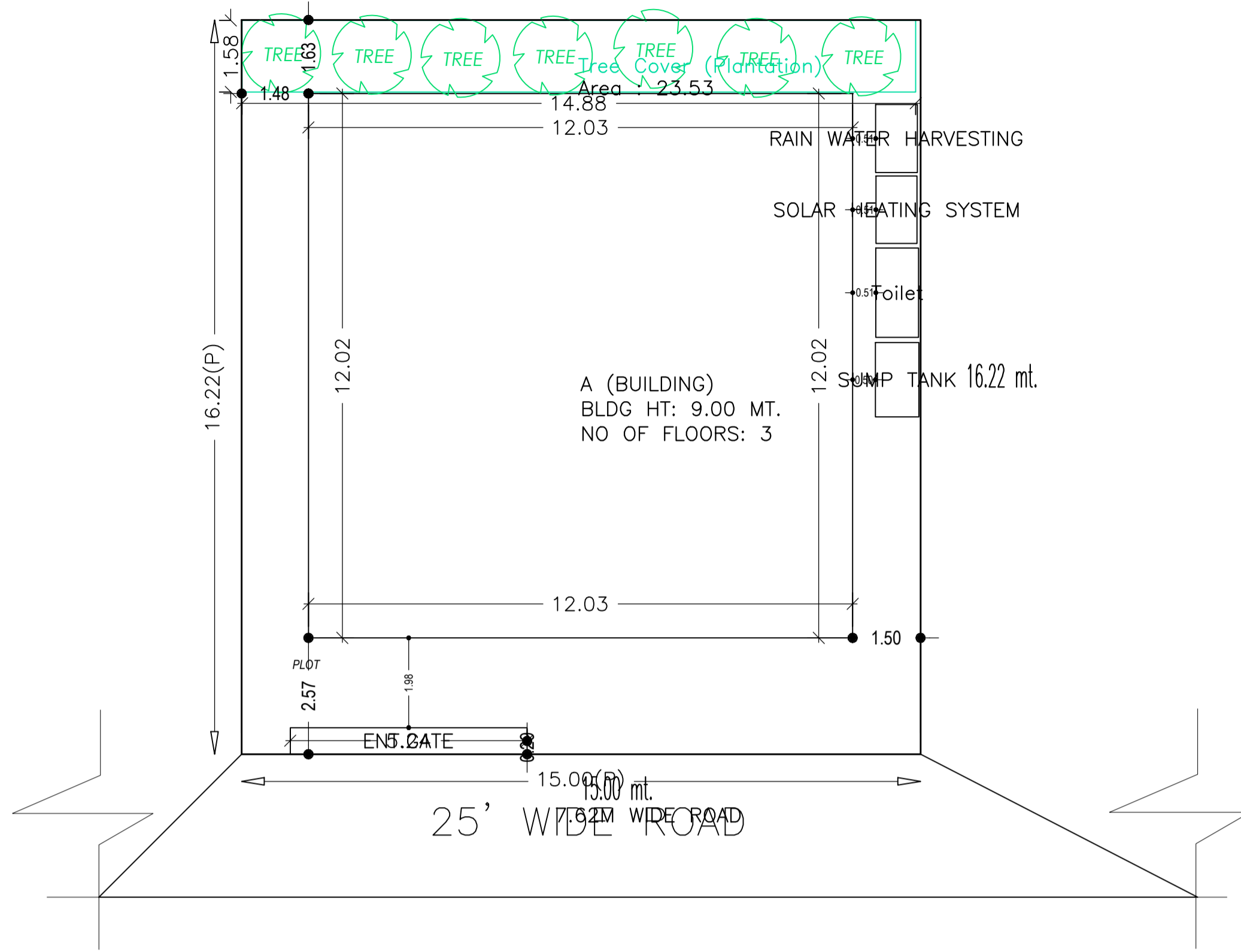

Buildingwise Floor FAR Details

Floor Name	Building Name A (BUILDING)		Total	
	Proposed Built Up Area (Sq.mt.)	Proposed FAR Area (Sq.mt.)	Total Proposed Built Up Area (Sq.mt.)	Total FAR Area (Sq.mt.)
Ground Floor	144.60	144.60	144.60	144.60
First Floor	144.60	144.60	144.60	144.60
Second Floor	144.60	144.60	144.60	144.60
Terrace Floor	0.00	0.00	0.00	0.00
Total :	433.80	433.80	433.80	433.80

Building USE/SUBUSE Details

Building Name	Building Use	Building SubUse	Building Structure
A (BUILDING)	Residential	Bungalow/ Dwelling / Non Apartment	Non-Highrise

COLOR INDEX	
PLOT BOUNDARY	[Red Line]
ABUTTING ROAD	[Green Line]
PROPOSED CONSTRUCTION	[Blue Area]
COMMON PLOT	[Yellow Area]
ROAD WIDENING AREA	[Orange Area]
EXISTING (To be retained)	[Light Blue Area]
EXISTING (To be demolished)	[Light Yellow Area]

FAR & Tenement Details (Table 4c-1)

Building	No. of Same Bldg	Total Built Up Area (Sq.mt.)	Proposed FAR Area (Sq.mt.) Resi.	Total FAR Area (Sq.mt.)	Total Consumed Additional FAR Area (Sq.mt.)	Tnmt (No.)
A (BUILDING)	1	433.80	433.80	433.80	433.80	01
Grand Total :	1	433.80	433.80	433.80	433.80	01

AREA STATEMENT		VERSION NO.: 1.0.61
MADHUPUR NAGAR PARISHAD		VERSION DATE: 16/10/2020
PROJECT DETAIL:		
Region: JHARKHAND URBAN LOCAL BODIES	Plot Use: Residential	
District: DEOGHAR	Plot SubUse: Bungalow/ Dwelling / Non Apartment	
Authority: MADHUPUR NAGAR PARISHAD	Plot/Nearby/Religious/Structure: NA	
Inward No: MNP/BP/0040/W07/2021	Plot/SubPlot No: 0/1	
Application Type: General Proposal	North: Plot No. - PROPOSED GALI	
Project Type: Building Permission	South: Plot No. - PARTITION WALL IN GARDEN LAND OF LESSOR	
Nature of Development: New	East: Plot No. - LESSORS BANGALOW NO 1	
Location of Development Area: Old Area	West: Road Width - 7.62	
AREA DETAILS:		
AREA OF PLOT (Minimum)	(A)	243.30
NET AREA OF PLOT(Gross Plot Area - Deduction from Gross Plot area)	(A-Deductions)	243.30
Deduction for Balance Plot Area(from Gross Plot Area)		
Common Plot		23.53
Total		23.53
BALANCE AREA OF PLOT(Net Plot Area - Recreational/Armenity space)	(A-Deductions)	219.77
PLOT AREA FOR COVERAGE(Net Plot Area)	(A-Deductions)	243.30
Plot Area for FAR (Net Plot Area + RoadWidening Area)	(A-Deductions)	243.30
COVERAGE CHECK		
Permissible Coverage area (60.00 %)		145.98
Proposed Coverage Area (59.43 %)		144.60
Total Prop. Coverage Area (59.43 %)		144.60
Balance coverage area (0.57 %)		1.38
FAR CHECK		
Perm. FAR Area (2.00)		486.60
Total Perm. FAR area		486.60
Residential FAR		433.80
Proposed FAR Area		433.80
Total Proposed FAR Area		433.80
Consumed FAR (Factor)		1.78
Balance FAR Area		52.80
BUILT UP AREA CHECK		
Total Proposed BuiltUp Area		433.80
ARCHITECT (Regd)	VISHAL YADAV	
ENGINEER (Regd)		
SUPERVISOR (Regd)		
OWNER (Regd)	BISHNU PRASAD TIBREWAL	
DEVELOPMENT AUTHORITY		LOCAL BODY

LTP NAME AND SIGNATURE	STRUCTURAL ENG'S NAME AND SIGNATURE	BUILDER NAME AND SIGNATURE	DIGITAL SIGNATURE
VISHAL YADAV MNP/ENG/0006/2020			

SITE PLAN

Proposal Basic Information	
Proposal File No	MNP/IBP/0040/W07/2021
Owner Name	BISHNU PRASAD TIBREWAL
Khata No	05
Plot No	0/1
Village Name	Bara Shekhpura
Use	Residential
SubUse	Bungalow/ Dwelling / Non Apartment

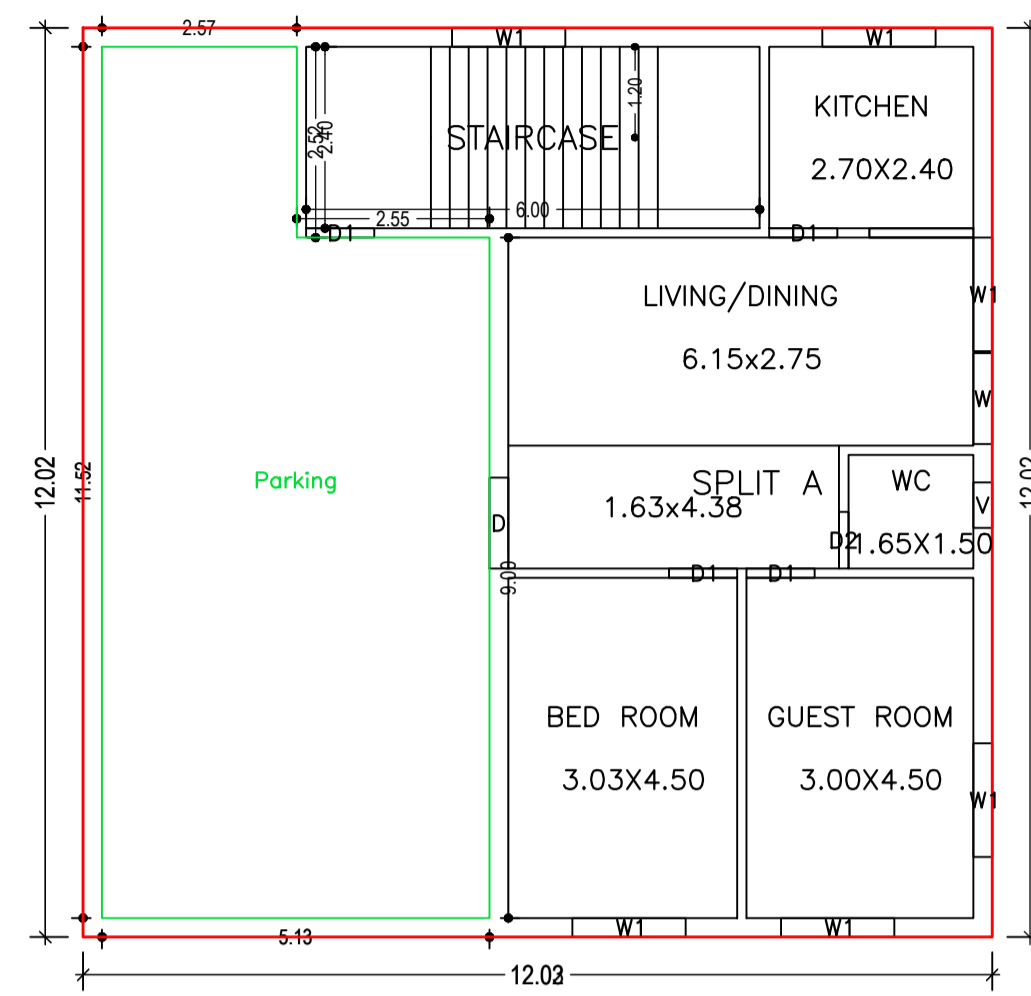

GROUND FLOOR PLAN
(Proposed)
(SCALE 1:100)

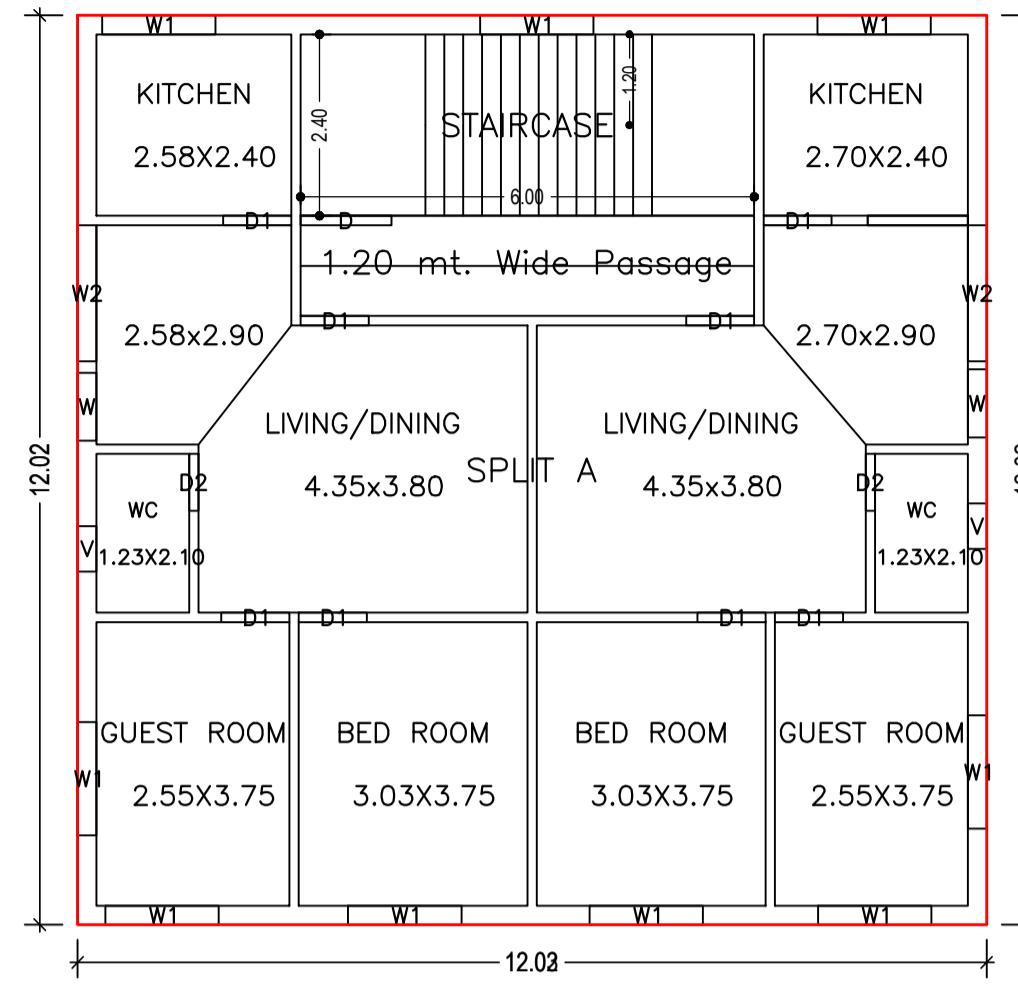

FIRST FLOOR PLAN
(Proposed)
(SCALE 1:100)

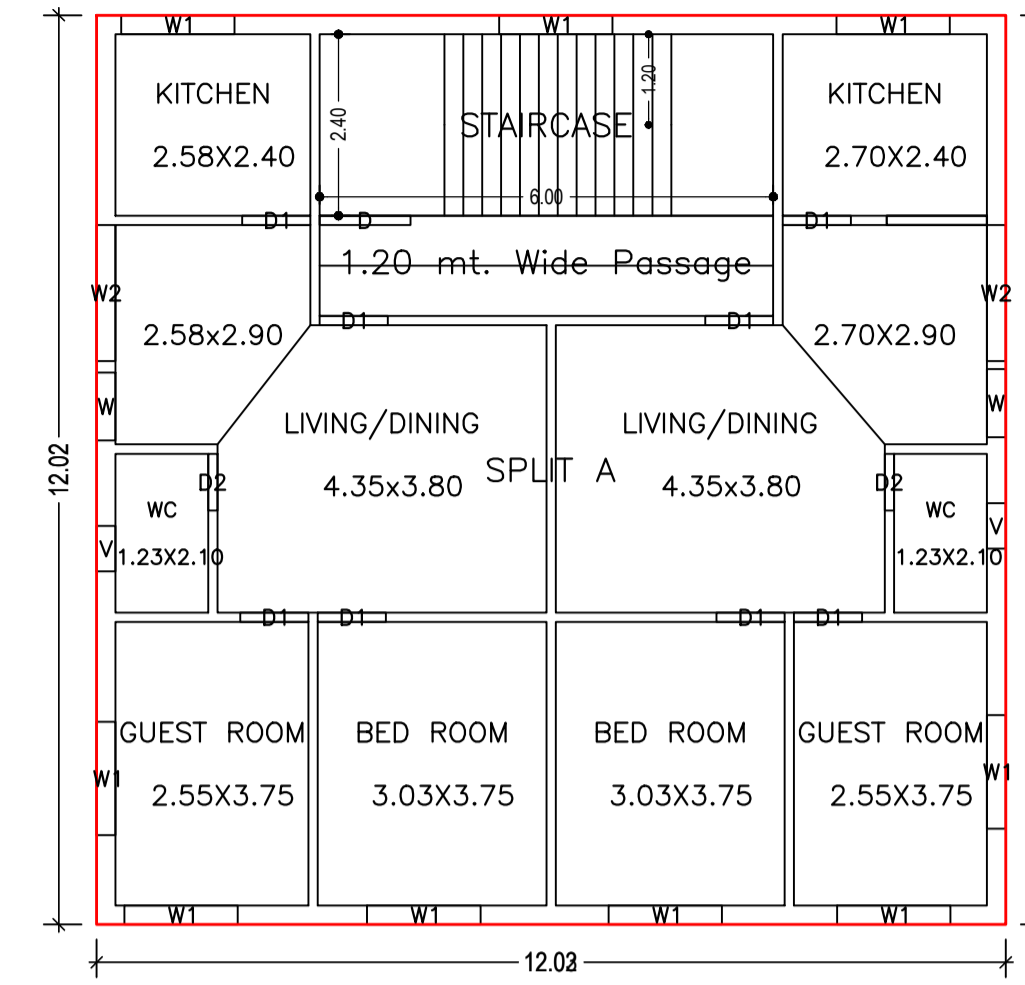

SECOND FLOOR PLAN
(Proposed)
(SCALE 1:100)

SCHEDULE OF DOOR:

BUILDING NAME	NAME	LENGTH	HEIGHT	NOS
A (BUILDING)	D2	0.75	2.10	05
A (BUILDING)	D1	0.90	2.10	19
A (BUILDING)	D	1.20	2.10	01

SCHEDULE OF WINDOW/VENTILATION:

BUILDING NAME	NAME	LENGTH	HEIGHT	NOS
A (BUILDING)	V	0.60	0.60	05
A (BUILDING)	W	0.90	1.20	04
A (BUILDING)	W	1.20	1.20	01
A (BUILDING)	W1	1.50	1.20	24
A (BUILDING)	W2	1.80	1.20	04

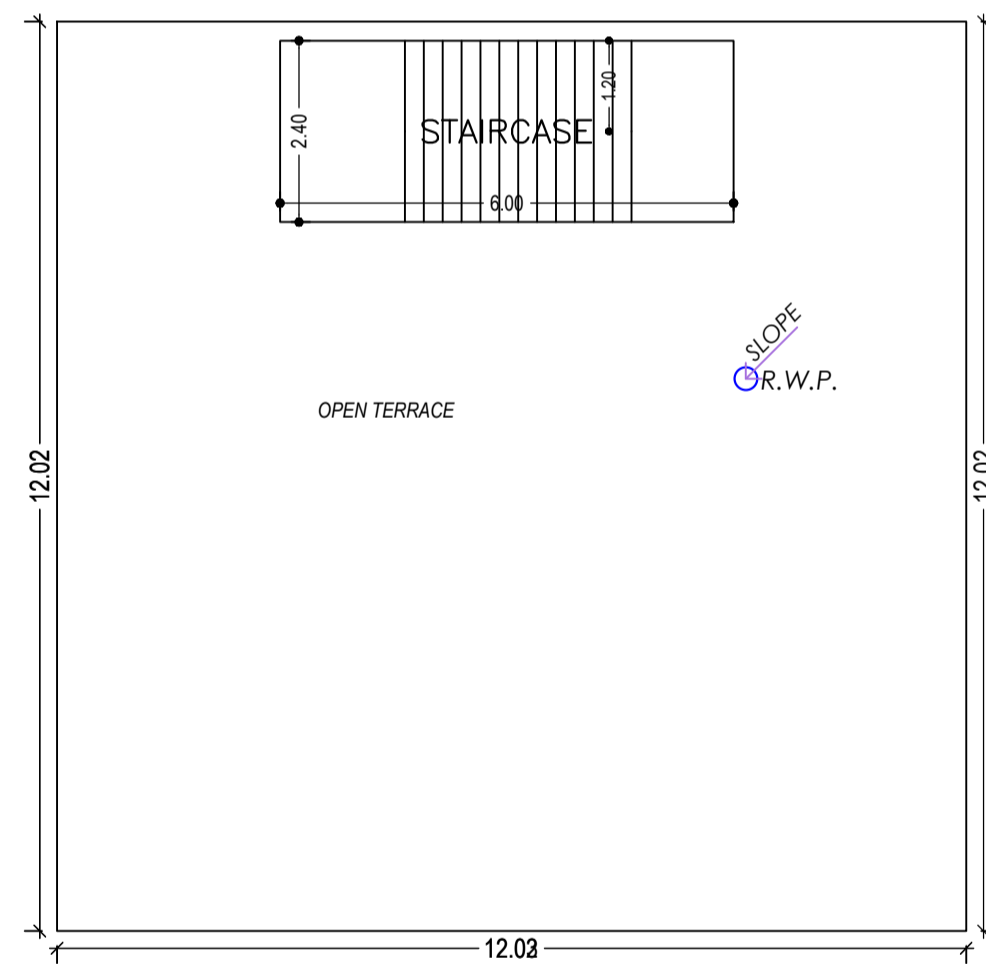

TERRACE FLOOR PLAN
(SCALE 1:100)

UnitBUA Table for Building :A (BUILDING)

FLOOR	Name	UnitBUA Type	UnitBUA Area	Carpet Area	No. of Rooms	No. of Tenement
GROUND FLOOR PLAN	SPLIT A	FLAT	279.69	279.19	5	1
FIRST FLOOR PLAN	SPLIT A	FLAT	0.00	0.00	10	0
SECOND FLOOR PLAN	SPLIT A	FLAT	0.00	0.00	10	0
Total:	-	-	279.69	279.19	25	1

Building :A (BUILDING)

Floor Name	Total Built Up Area (Sq.mt.)	Proposed FAR Area (Sq.mt.)		Total Consumed Additional FAR Area (Sq.mt.)	Trmt (No.)
		Resi.	Resi.		
Ground Floor	144.60	144.60	144.60	144.60	01
First Floor	144.60	144.60	144.60	144.60	00
Second Floor	144.60	144.60	144.60	144.60	00
Terrace Floor	0.00	0.00	0.00	0.00	00
Total :	433.80	433.80	433.80	433.80	01
Total Number of Same Buildings :	1				
Total :	433.80	433.80	433.80	433.80	01

LTP NAME AND SIGNATURE	STRUCTURAL ENG'S NAME AND SIGNATURE	BUILDER NAME AND SIGNATURE	DIGITAL SIGNATURE
VISHAL YADAV MNP/ENG/0006/2020			

Proposal Basic Information	
Proposal File No	MNP/0040/W07/2021
Owner Name	BISHNU PRASAD TIBREWAL
Khata No	05
Plot No	0/1
Village Name	Bara Shekhpura
Use	Residential
SubUse	Bungalow/ Dwelling / Non Apartment

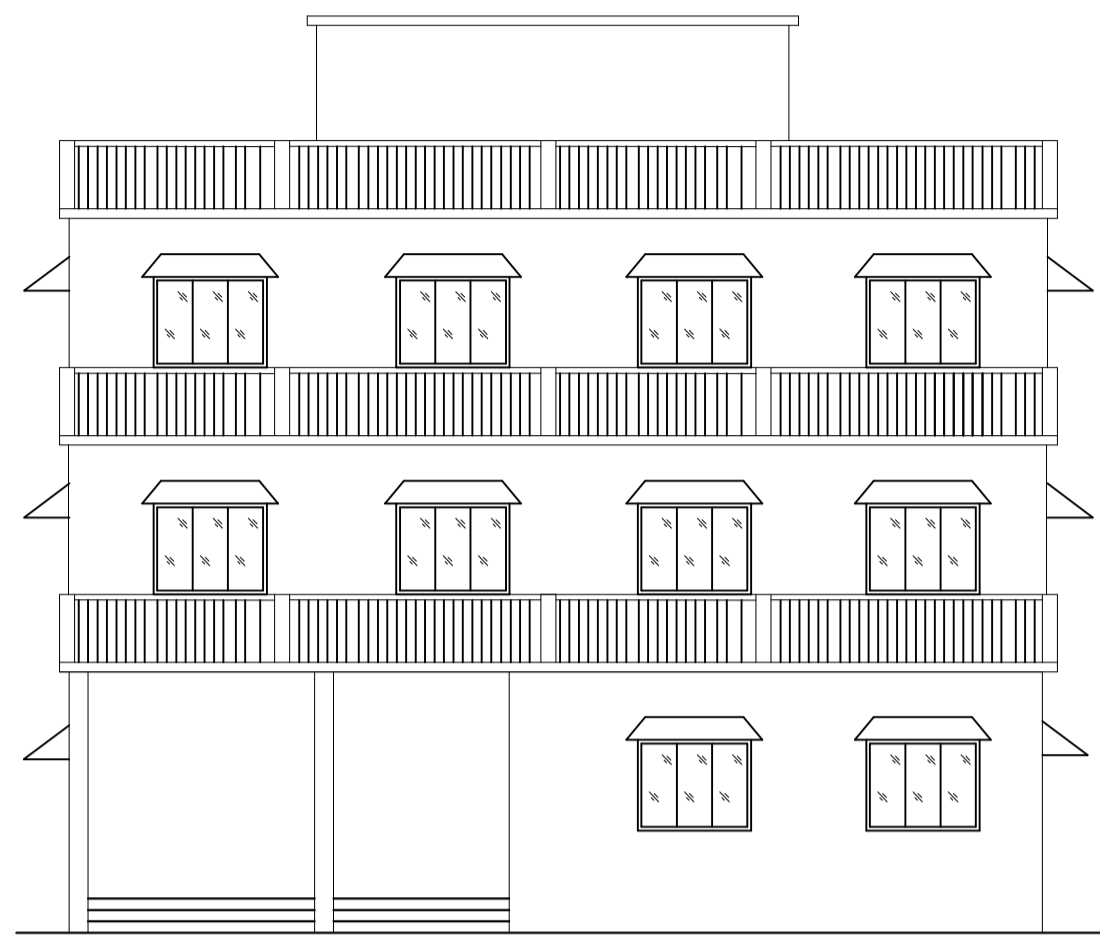

FRONT ELEVATION
SCALE :- 1:100



RIGHT SIDE ELEVATION
SCALE :- 1:100

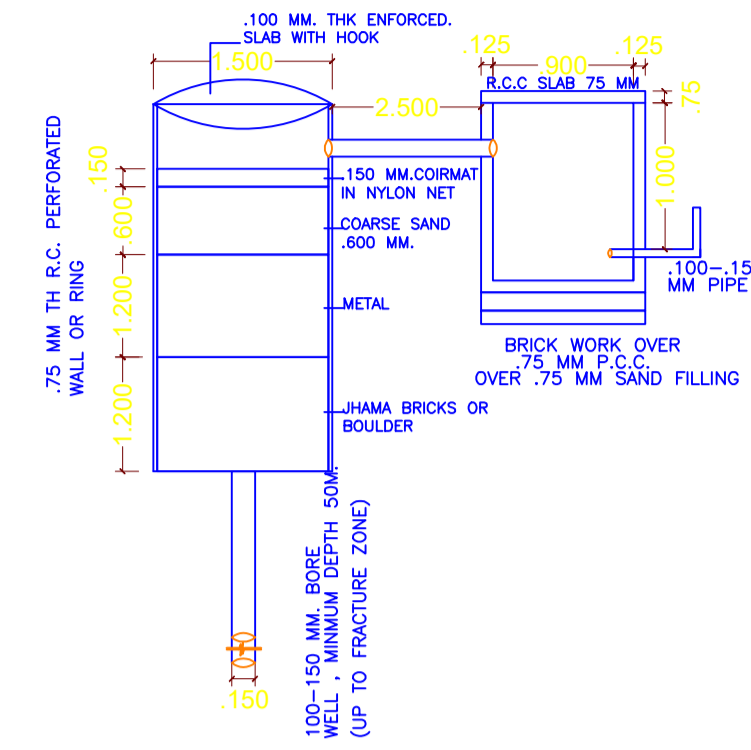

DETAIL OF GROUND WATER RECHAREGING PIT WITH SLIT TANK
(SCALE 1:50)

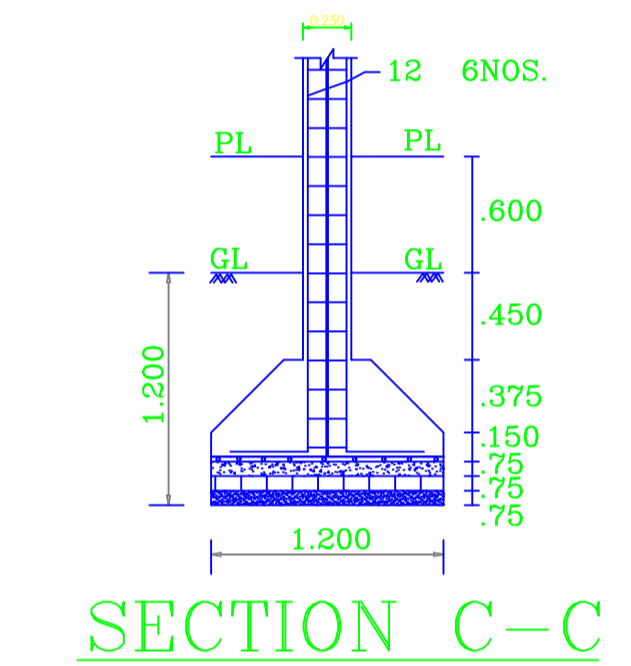

SECTION C-C

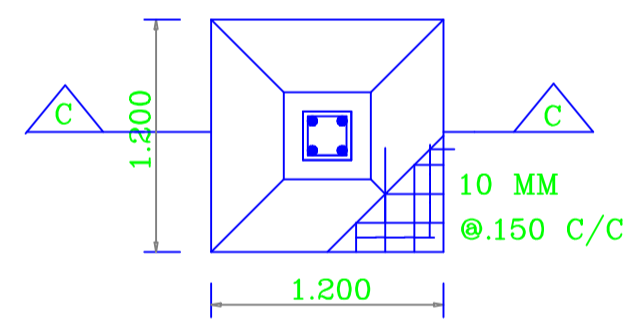

PLAN R.C.C.COLUMN FOUNDN.
(SCALE- 1:50)

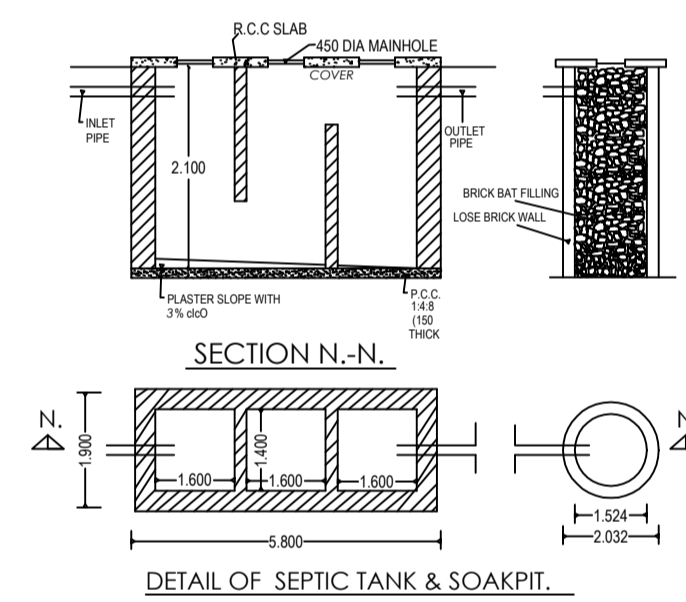
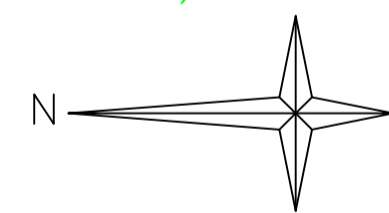

SECTION N-N.

DETAIL OF SEPTIC TANK & SOAKPIT.

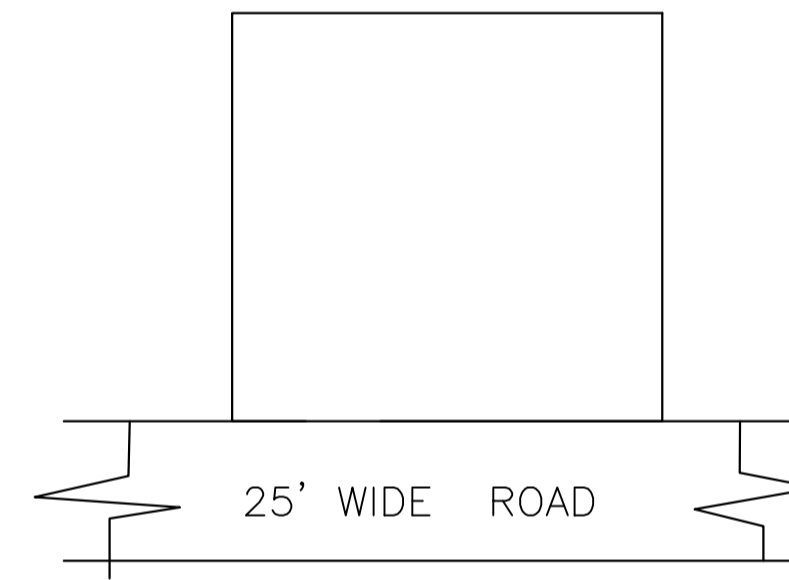

LOCATION PLAN
SCALE :- 1:100

LTP NAME AND SIGNATURE	STRUCTURAL ENG'S NAME AND SIGNATURE	BUILDER NAME AND SIGNATURE	DIGITAL SIGNATURE
VISHAL YADAV MNP/ENG/0006/2020			