

AREA STATEMENT MADHUPUR NAGAR PARISHAD	VERSION NO. : 1.0.65 VERSION DATE: 16/10/2020		
PROJECT DETAIL:			
Region : JHARKHAND URBAN LOCAL BODIES	Plot Use: Residential		
District: DEOGHAR	Plot SubUse: Bungalow/ Dwelling / Non Apartment		
Authority: MADHUPUR NAGAR PARISHAD	Plot/Nearby/Religious/Structure: NA		
Inward No: MNP/BP/0069/W02/2022	Plot/SubPlot No: 0/1		
Application Type: General Proposal	North: Plot No. - land of mityunjay banerjee		
Project Type: Building Permission	South: Plot No. - vendors land		
Nature of Development: New	East: Road Width - 3.0		
Location of Development Area: Old Area	West: Plot No. - wood house		
AREA DETAILS:			
AREA OF PLOT (Minimum)	(A)	SQ.MT.	103.64
Deduction for NetPlot Area			
Surrender Free of Cost			2.29
Total			2.29
NET AREA OF PLOT(Gross Plot Area - Deduction from Gross Plot area)			
(A-Deductions)			101.35
Deduction for Balance Plot Area(from Gross Plot Area)			
Surrender Free of Cost			2.29
Common Plot			14.70
Total			16.99
BALANCE AREA OF PLOT(Net Plot Area - Recreational/Amenity space)			
(A-Deductions)			86.65
PLOT AREA FOR COVERAGE(Net Plot Area)			
(A-Deductions)			101.35
Plot Area for FAR (Net Plot Area + RoadWidening Area)			
(A-Deductions)			103.64
COVERAGE CHECK			
Permissible Coverage area (70.00 %)			70.94
Proposed Coverage Area (64.61 %)			65.48
Total Prop. Coverage Area (64.61 %)			65.48
Balance coverage area (5.39 %)			5.46
FAR CHECK			
Perm. FAR Area (1.200)			124.37
Total Perm. FAR area			124.37
Residential FAR			65.48
Proposed FAR Area			65.48
Total Proposed FAR Area			65.48
Consumed FAR (Factor)			0.63
Balance FAR Area			58.89
BUILT UP AREA CHECK			
Total Proposed BuiltUp Area			65.48
ARCHITECT (Regd)		VISHAL YADAV	
ENGINEER (Regd)			
SUPERVISOR (Regd)			
OWNER (Regd)		KAMLA DEVI	
DEVELOPMENT AUTHORITY		LOCAL BODY	

Building USE/SUBUSE Details

Building Name	Building Use	Building SubUse	Building Structure
A (RESIDENTIAL)	Residential	Bungalow/ Dwelling / Non Apartment	Non-Highrise

Proposal Basic Information

Proposal File No.	MNP/BP/0069/W02/2022
Owner Name	KAMLA DEVI
Khata No	7
Plot No	0/1
Village Name	Sapha
Use	Residential
SubUse	Bungalow/ Dwelling / Non Apartment

FAR & Tenement Details (Table 4c-1)

Building	No. of Same Bldg	Total Built Up Area (Sq.mt.)	Proposed FAR Area (Sq.mt.) Resi.	Total FAR Area (Sq.mt.)	Total Consumed Additional FAR Area (Sq.mt.)	Trmt (No.)
A (RESIDENTIAL)	1	65.48	65.48	65.48	65.48	01
Grand Total :	1	65.48	65.48	65.48	65.48	01

Buildingwise Floor FAR Details

Floor Name	Building Name A (RESIDENTIAL)		Total	
	Proposed Built Up Area (Sq.mt.)	Proposed FAR Area (Sq.mt.)	Total Proposed Built Up Area (Sq.mt.)	Total FAR Area (Sq.mt.)
Ground Floor	65.48	65.48	65.48	65.48
Terrace Floor	0.00	0.00	0.00	0.00
Total :	65.48	65.48	65.48	65.48

COLOR INDEX

PLOT BOUNDARY	[Red Line]
ABUTTING ROAD	[Green Line]
PROPOSED CONSTRUCTION	[Blue Line]
COMMON PLOT	[Yellow Line]
ROAD WIDENING AREA	[Orange Line]
EXISTING (To be retained)	[Purple Line]
EXISTING (To be demolished)	[Light Blue Line]

SITE

LTP NAME AND SIGNATURE	STRUCTURAL ENG'S NAME AND SIGNATURE	BUILDER NAME AND SIGNATURE	DIGITAL SIGNATURE
VISHAL YADAV MNP/ENG/0006/2020			

Proposal Basic Information

Proposal File No.	MNP/EP/0069/W02/2022
Owner Name	KAMLA DEVI
Khata No	7
Plot No	0/1
Village Name	Sapha
Use	Residential
SubUse	Bungalow/ Dwelling / Non Apartment

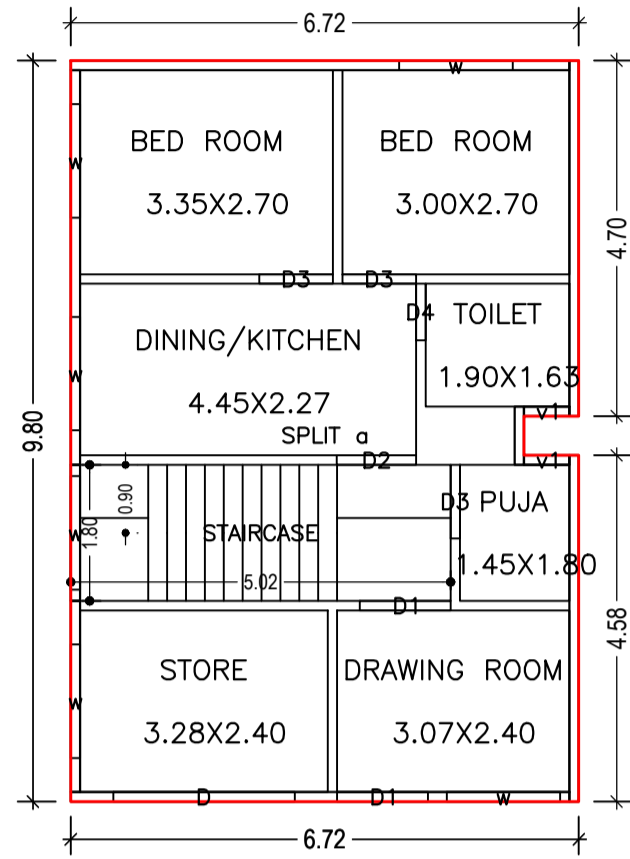

GROUND FLOOR PLAN
(Proposed)
(SCALE 1:100)

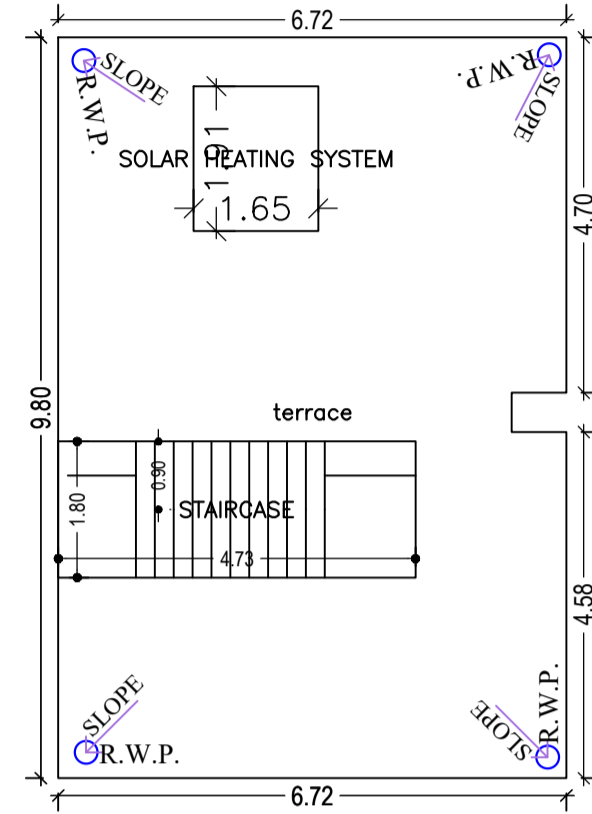

TERRACE FLOOR PLAN
(SCALE 1:100)

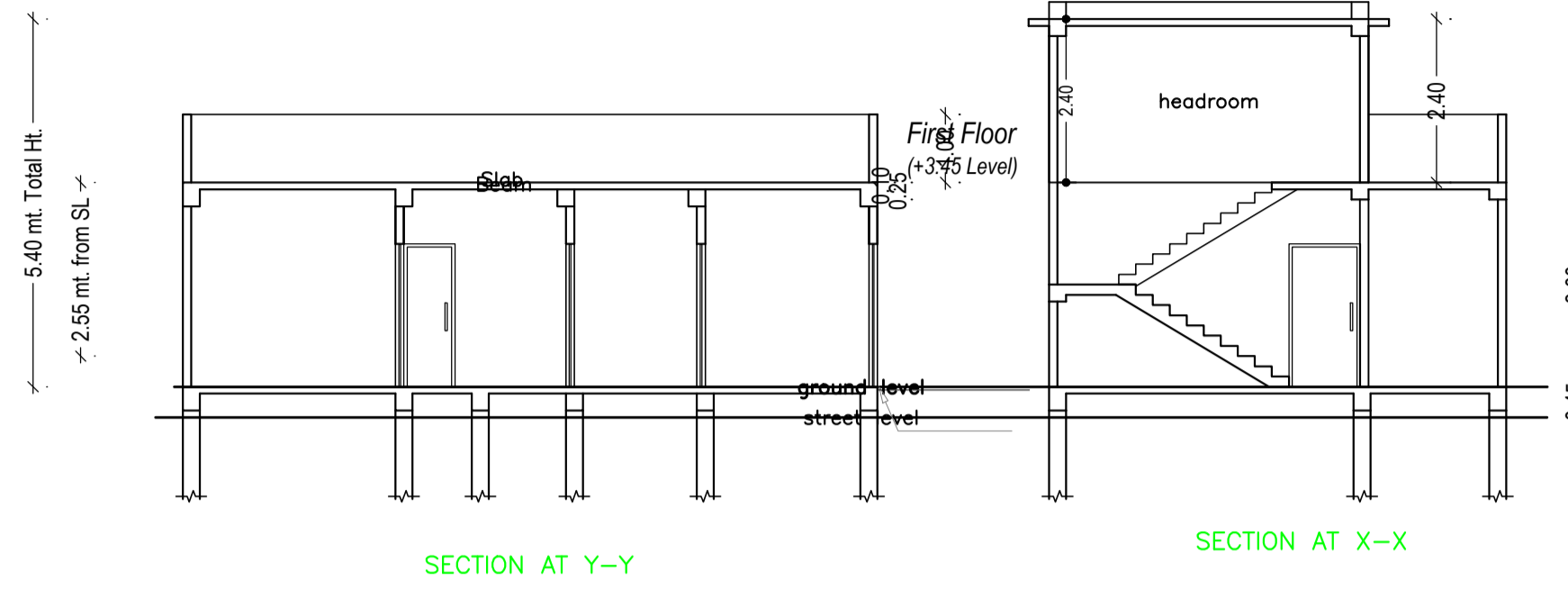

UnitBUA Table for Building :A (RESIDENTIAL)

FLOOR	Name	UnitBUA Type	UnitBUA Area	Carpet Area	No. of Rooms	No. of Tenement
GROUND FLOOR PLAN	SPLIT a	FLAT	56.44	52.41	7	1
Total:	-	-	56.44	52.41	7	1

SCHEDULE OF DOOR:

BUILDING NAME	NAME	LENGTH	HEIGHT	NOS
A (RESIDENTIAL)	D4	0.75	2.10	01
A (RESIDENTIAL)	D3	0.98	2.10	03
A (RESIDENTIAL)	D2	1.05	2.10	01
A (RESIDENTIAL)	D1	1.20	2.10	02
A (RESIDENTIAL)	D	2.40	2.10	01

SCHEDULE OF WINDOW/VENTILATION:

BUILDING NAME	NAME	LENGTH	HEIGHT	NOS
A (RESIDENTIAL)	v1	0.60	0.60	02
A (RESIDENTIAL)	w	1.50	1.20	06

Building :A (RESIDENTIAL)

Floor Name	Total Built Up Area (Sq.mt.)	Proposed FAR Area (Sq.mt.) Resi.	Total FAR Area (Sq.mt.)	Total Consumed Additional FAR Area (Sq.mt.)	Tnmt (No.)
Ground Floor	65.48	65.48	65.48	65.48	01
Terrace Floor	0.00	0.00	0.00	0.00	00
Total :	65.48	65.48	65.48	65.48	01
Total Number of Same Buildings :	1				
Total :	65.48	65.48	65.48	65.48	01

LTP NAME AND SIGNATURE	STRUCTURAL ENG'S NAME AND SIGNATURE	BUILDER NAME AND SIGNATURE	DIGITAL SIGNATURE
VISHAL YADAV MNP/ENG/0006/2020			

Proposal Basic Information

Proposal File No.	MNP/EP/0069/W02/2022
Owner Name	KAMLA DEVI
Khata No	7
Plot No	0/1
Village Name	Sapha
Use	Residential
SubUse	Bungalow/ Dwelling / Non Apartment

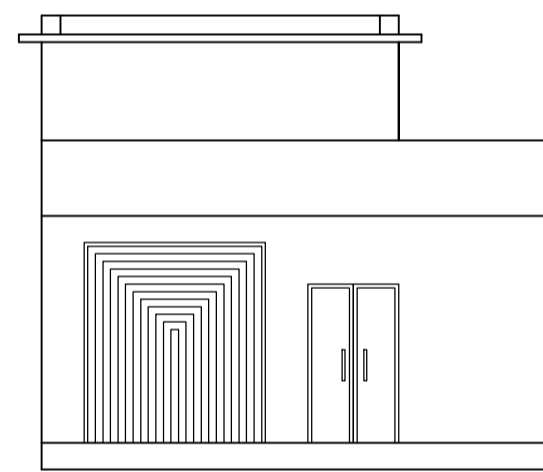
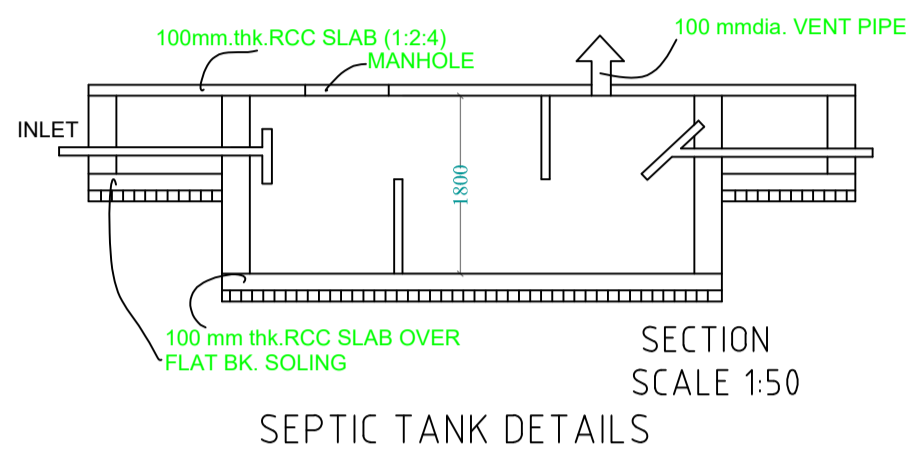
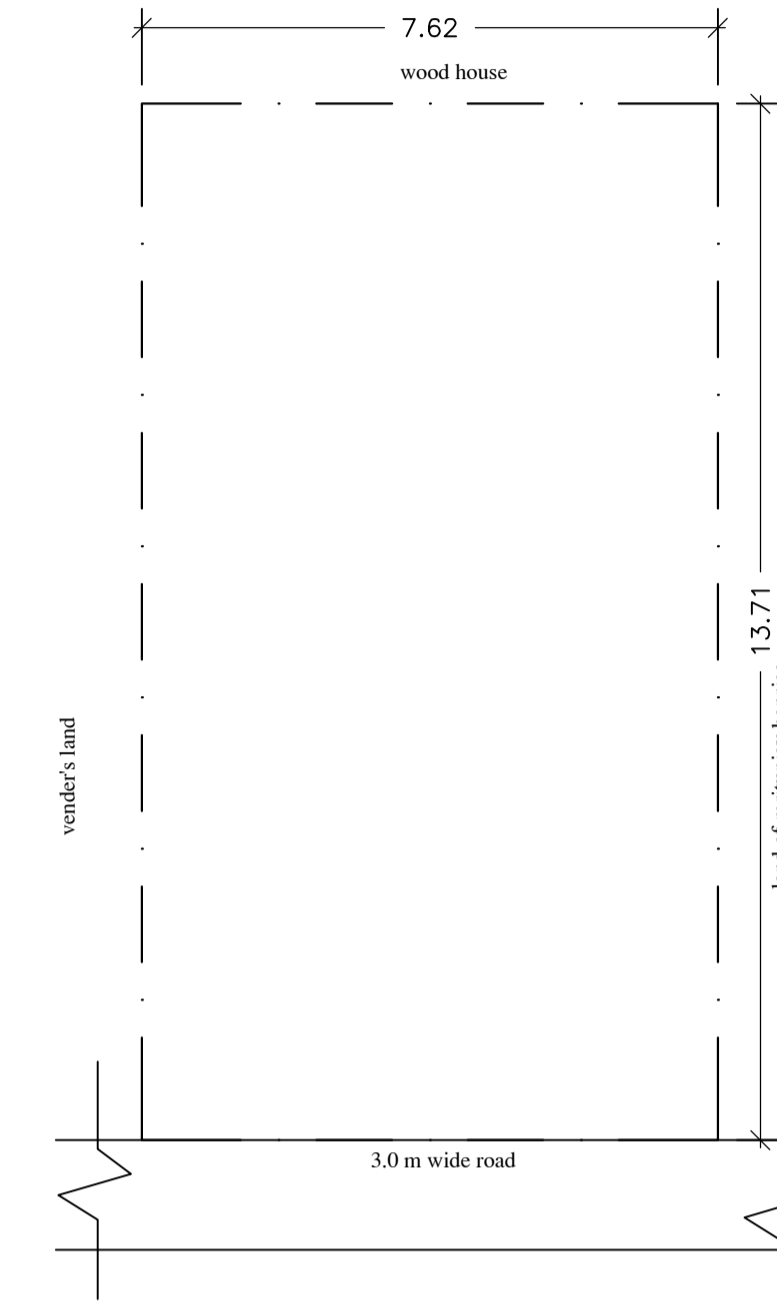
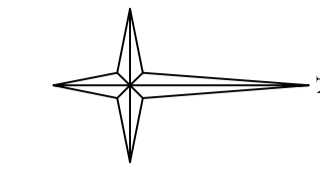
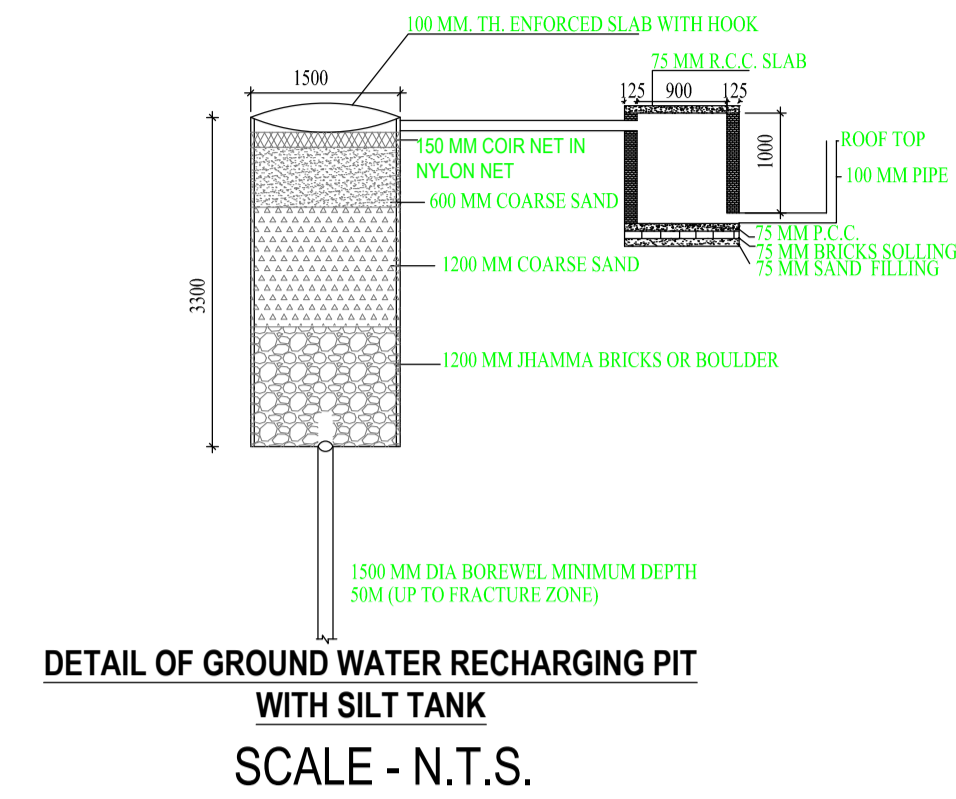
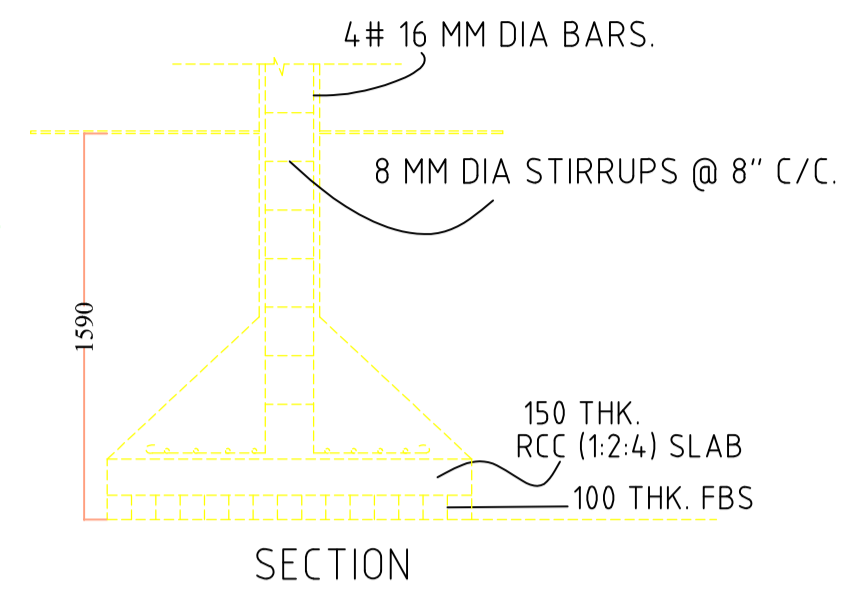
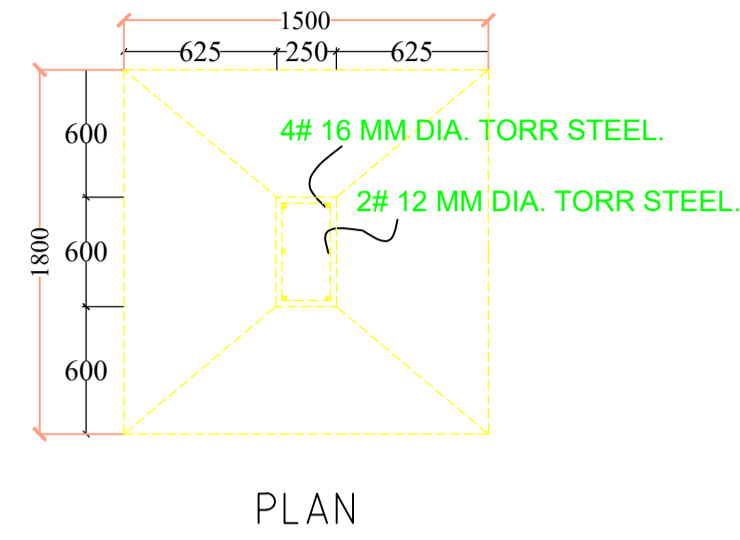
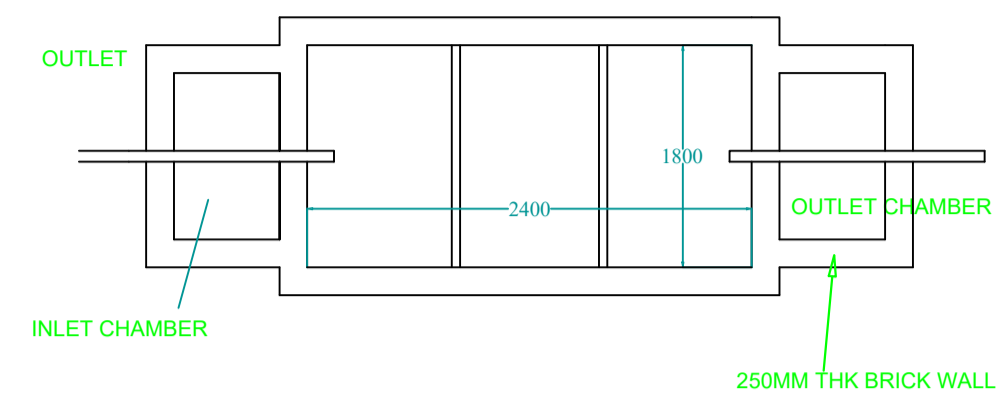

CERTIFICATE:
THIS IS CERTIFY THAT THE STRUCTURAL DESIGN OF THIS BUILDING IS AS PER IS CODE 189-1884-& 1993 TO MAKE THE SAME.

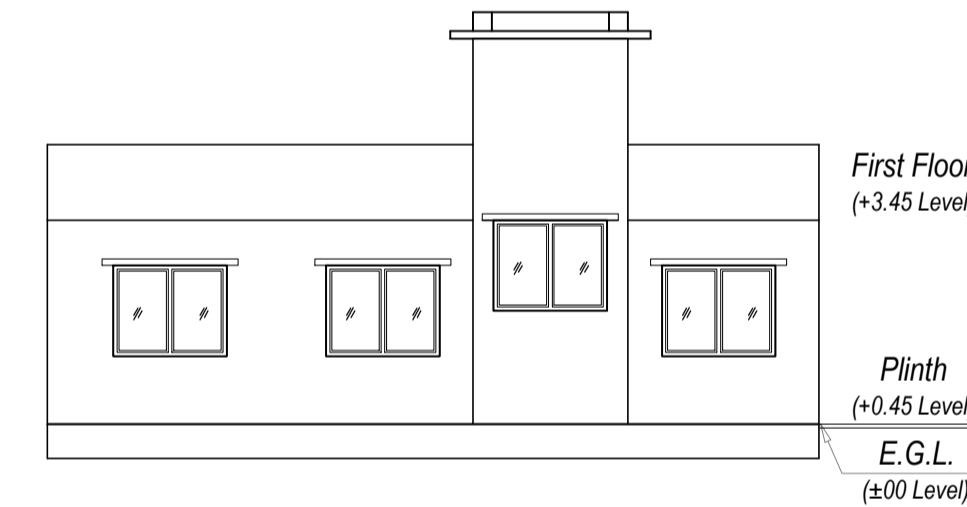

LTP NAME AND SIGNATURE	STRUCTURAL ENG'S NAME AND SIGNATURE	BUILDER NAME AND SIGNATURE	DIGITAL SIGNATURE
VISHAL YADAV MNP/ENG/0006/2020			