

Proposal Basic Information	
Proposal File No.	MNP/BI/0016/W07/2022
Owner Name	SHAKUNTALA DEVI SINGHANIA
Khata No	33/20
Plot No	NA
Village Name	Bara Shekhpura
Use	Residential
SubUse	Bungalow/ Dwelling / Non Apartment

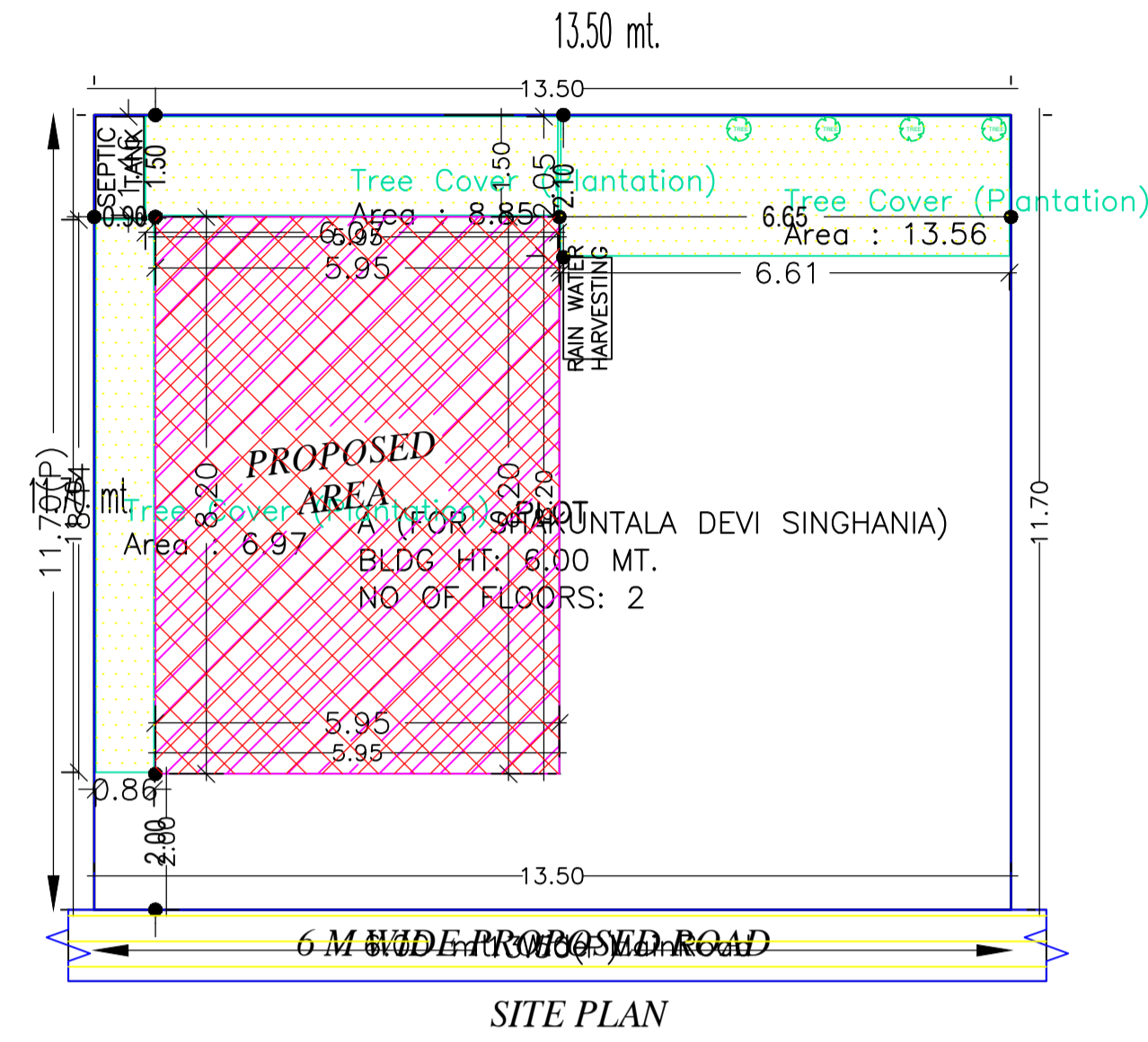

SITE PLAN

AREA STATEMENT	VERSION NO.: 1.0.62		
MADHUPUR NAGAR PARISHAD	VERSION DATE: 16/10/2020		
PROJECT DETAIL			
Region: JHARKHAND URBAN LOCAL BODIES	Plot Use: Residential		
District: DEOGHAR	Plot SubUse: Bungalow/ Dwelling / Non Apartment		
Authority: MADHUPUR NAGAR PARISHAD	PlotNearbyReligiousStructure: NA		
Inward No: MNP/BI/0016/W07/2022	PlotSubPlot No: NA		
Application Type: General Proposal	North: Plot No. - VENDORS LAND		
Project Type: Building Permission	South: Road Width - 6.0		
Nature of Development: New	East: Plot No. - VENDORS LAND		
Location of Development Area: Old Area	West: Plot No. - VENDORS LAND		
AREA DETAILS:			
AREA OF PLOT (Minimum)	(A)	SQ.MT.	154.36
NET AREA OF PLOT(Gross Plot Area - Deduction from Gross Plot area)	(A-Deductions)		154.36
Deduction for Balance Plot Area(from Gross Plot Area)			
Common Plot			29.38
Total			29.38
BALANCE AREA OF PLOT(Net Plot Area - Recreational/Amenity space)	(A-Deductions)		124.98
PLOT AREA FOR COVERAGE(Net Plot Area)	(A-Deductions)		154.36
Plot Area for FAR (Net Plot Area + Road/Widening Area)	(A-Deductions)		154.36
COVERAGE CHECK			
Permissible Coverage area (70.00 %)			108.05
Proposed Coverage Area (31.61 %)			48.79
Total Prop. Coverage Area (31.61 %)			48.79
Balance coverage area (38.39 %)			59.26
FAR CHECK			
Perm. FAR Area (1.80)			277.85
Total Perm. FAR area			277.85
Residential FAR			97.58
Proposed FAR Area			97.58
Total Proposed FAR Area			97.58
Consumed FAR (Factor)			0.63
Balance FAR Area			180.27
BUILT UP AREA CHECK			
Total Proposed BuiltUp Area			97.58
ARCHITECT (Regd)			RAJKISHOR KUMAR
ENGINEER (Regd)			
SUPERVISOR (Regd)			
OWNER (Regd)			SHAKUNTALA DEVI SINGHANIA
DEVELOPMENT AUTHORITY		LOCAL BODY	

Building USE/SUBUSE Details

Building Name	Building Use	Building SubUse	Building Structure
A (FOR SHAKUNTALA DEVI SINGHANIA)	Residential	Bungalow/ Dwelling / Non Apartment	Non-Highrise

Buildingwise Floor FAR Details

Floor Name	Building Name		Total	
	Proposed Built Up Area (Sq.mt.)	Proposed FAR Area (Sq.mt.)	Total Proposed Built Up Area (Sq.mt.)	Total FAR Area (Sq.mt.)
Ground Floor	48.79	48.79	48.79	48.79
First Floor	48.79	48.79	48.79	48.79
Terrace Floor	0.00	0.00	0.00	0.00
Total :	97.58	97.58	97.58	97.58

FAR & Tenement Details (Table 4c-1)

Building	No. of Same Bldg	Total Built Up Area (Sq.mt.)	Proposed FAR Area (Sq.mt.) Resi.	Total FAR Area (Sq.mt.)	Total Consumed Additional FAR Area (Sq.mt.)	Tnmt (No.)
A (FOR SHAKUNTALA DEVI SINGHANIA)	1	97.58	97.58	97.58	97.58	01
Grand Total :	1	97.58	97.58	97.58	97.58	01

COLOR INDEX	
PLOT BOUNDARY	Black
ABUTTING ROAD	Green
PROPOSED CONSTRUCTION	Red
COMMON PLOT	Yellow
ROAD WIDENING AREA	Blue
EXISTING (To be retained)	Light Blue
EXISTING (To be demolished)	Light Yellow

LTP NAME AND SIGNATURE	STRUCTURAL ENG'S NAME AND SIGNATURE	BUILDER NAME AND SIGNATURE	DIGITAL SIGNATURE
RAJKISHOR KUMAR MNP/ENG/0003/2018			

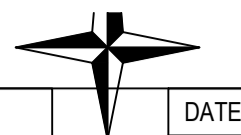

Proposal Basic Information

Proposal File No.	MNP/BI/0016/W07/2022
Owner Name	SHAKUNTALA DEVI SINGHANIA
Khata No	33/20
Plot No	NA
Village Name	Bara Shekhpura
Use	Residential
SubUse	Bungalow/ Dwelling / Non Apartment

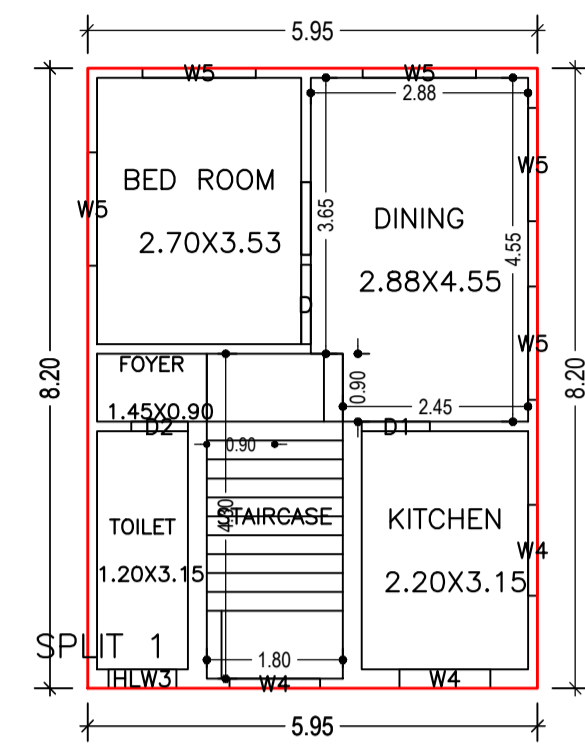

GROUND FLOOR PLAN
(Proposed)
(SCALE 1:100)

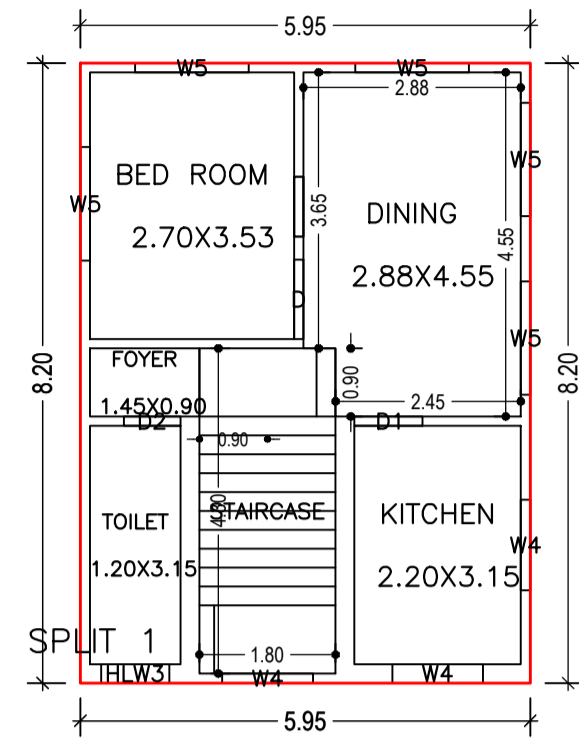

FIRST FLOOR PLAN
(Proposed)
(SCALE 1:100)

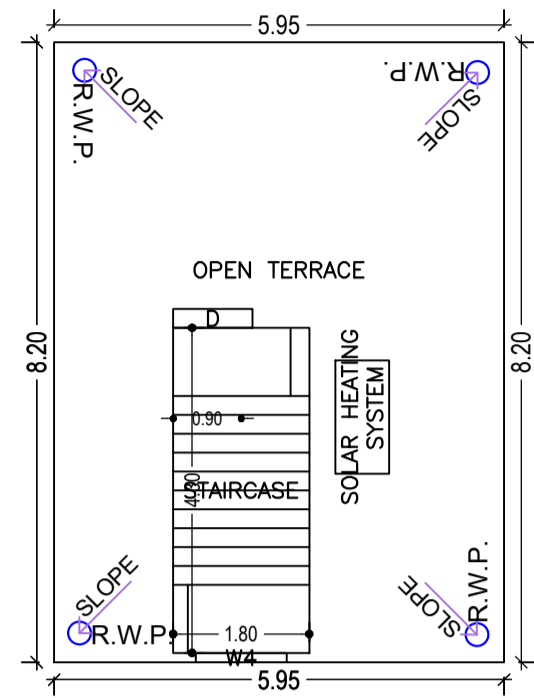

TERRACE FLOOR PLAN
(SCALE 1:100)

UnitBUA Table for Building :A (FOR SHAKUNTALA DEVI SINGHANIA)

FLOOR	Name	UnitBUA Type	UnitBUA Area	Carpet Area	No. of Rooms	No. of Tenement
GROUND FLOOR PLAN	SPLIT 1	FLAT	74.18	73.96	5	1
FIRST FLOOR PLAN	SPLIT 1	FLAT	0.00	0.00	5	0
Total:	-	-	74.18	73.96	10	1

SCHEDULE OF DOOR:

BUILDING NAME	NAME	LENGTH	HEIGHT	NOS
A (FOR SHAKUNTALA DEVI SINGHANIA)	D2	0.75	2.10	02
A (FOR SHAKUNTALA DEVI SINGHANIA)	D1	0.90	2.10	02
A (FOR SHAKUNTALA DEVI SINGHANIA)	D	1.05	2.10	02

SCHEDULE OF WINDOW/VENTILATION:

BUILDING NAME	NAME	LENGTH	HEIGHT	NOS
A (FOR SHAKUNTALA DEVI SINGHANIA)	HLW3	0.90	0.60	02
A (FOR SHAKUNTALA DEVI SINGHANIA)	W4	1.20	1.35	07
A (FOR SHAKUNTALA DEVI SINGHANIA)	W5	1.50	1.35	10

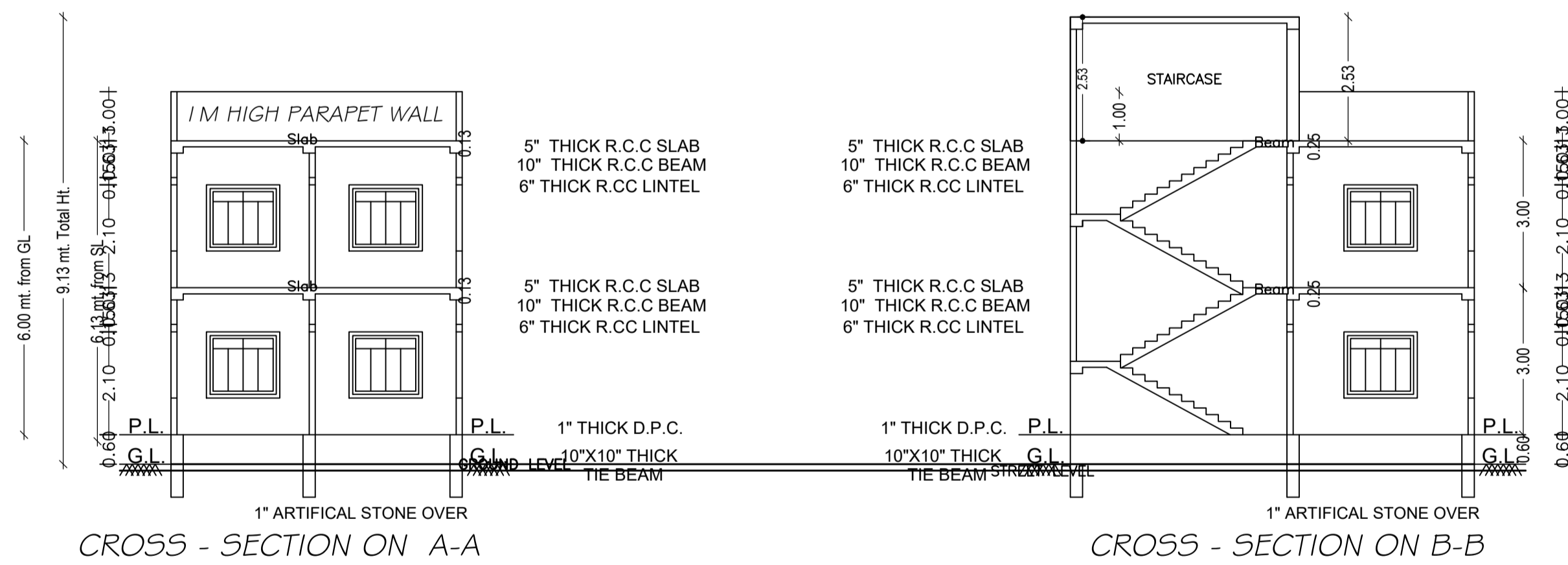

CROSS - SECTION ON A-A

CROSS - SECTION ON B-B

Building :A (FOR SHAKUNTALA DEVI SINGHANIA)

Floor Name	Total Built Up Area (Sq.mt.)	Proposed FAR Area (Sq.mt.) Resi.	Total FAR Area (Sq.mt.)	Total Consumed Additional FAR Area (Sq.mt.)	Trmt (No.)
Ground Floor	48.79	48.79	48.79	48.79	01
First Floor	48.79	48.79	48.79	48.79	00
Terrace Floor	0.00	0.00	0.00	0.00	00
Total	97.58	97.58	97.58	97.58	01
Total Number of Same Buildings	1				
Total :	97.58	97.58	97.58	97.58	01

LTP NAME AND SIGNATURE	STRUCTURAL ENG'S NAME AND SIGNATURE	BUILDER NAME AND SIGNATURE	DIGITAL SIGNATURE
RAJKISHOR KUMAR MNP/ENG/0003/2018			

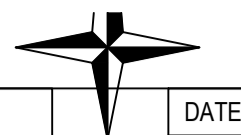

DATE	07-03-2022
SHEET NO.	3

Proposal Basic Information	
Proposal File No.	MNP/BI/0016/W07/2022
Owner Name	SHAKUNTALA DEVI SINGHANIA
Khata No	33/20
Plot No	NA
Village Name	Bara Shekhpura
Use	Residential
SubUse	Bungalow/ Dwelling / Non Apartment

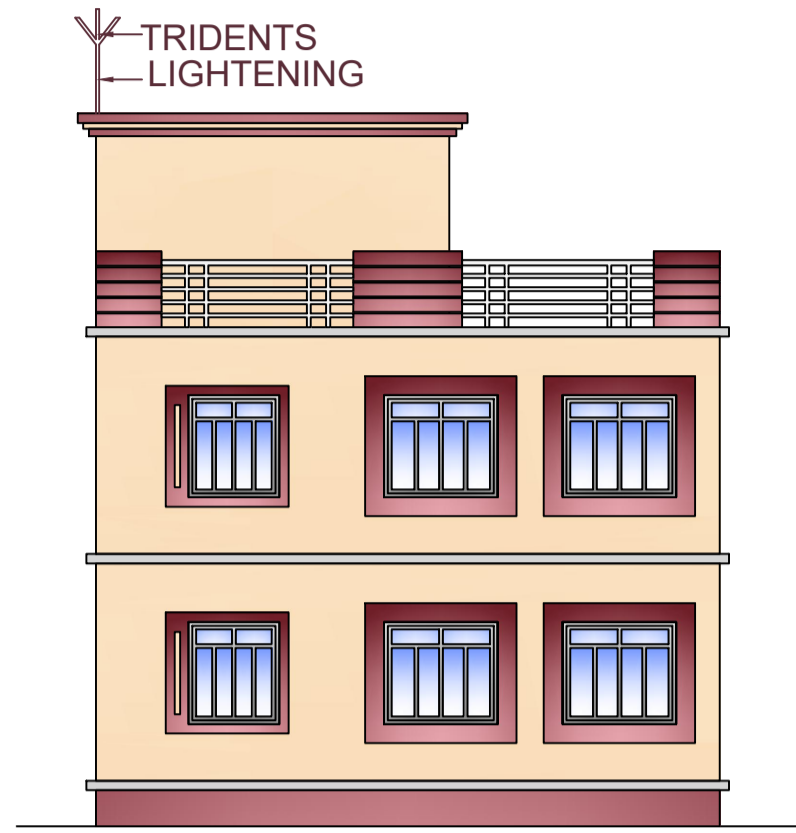

RIGHT SIDE ELEVATION

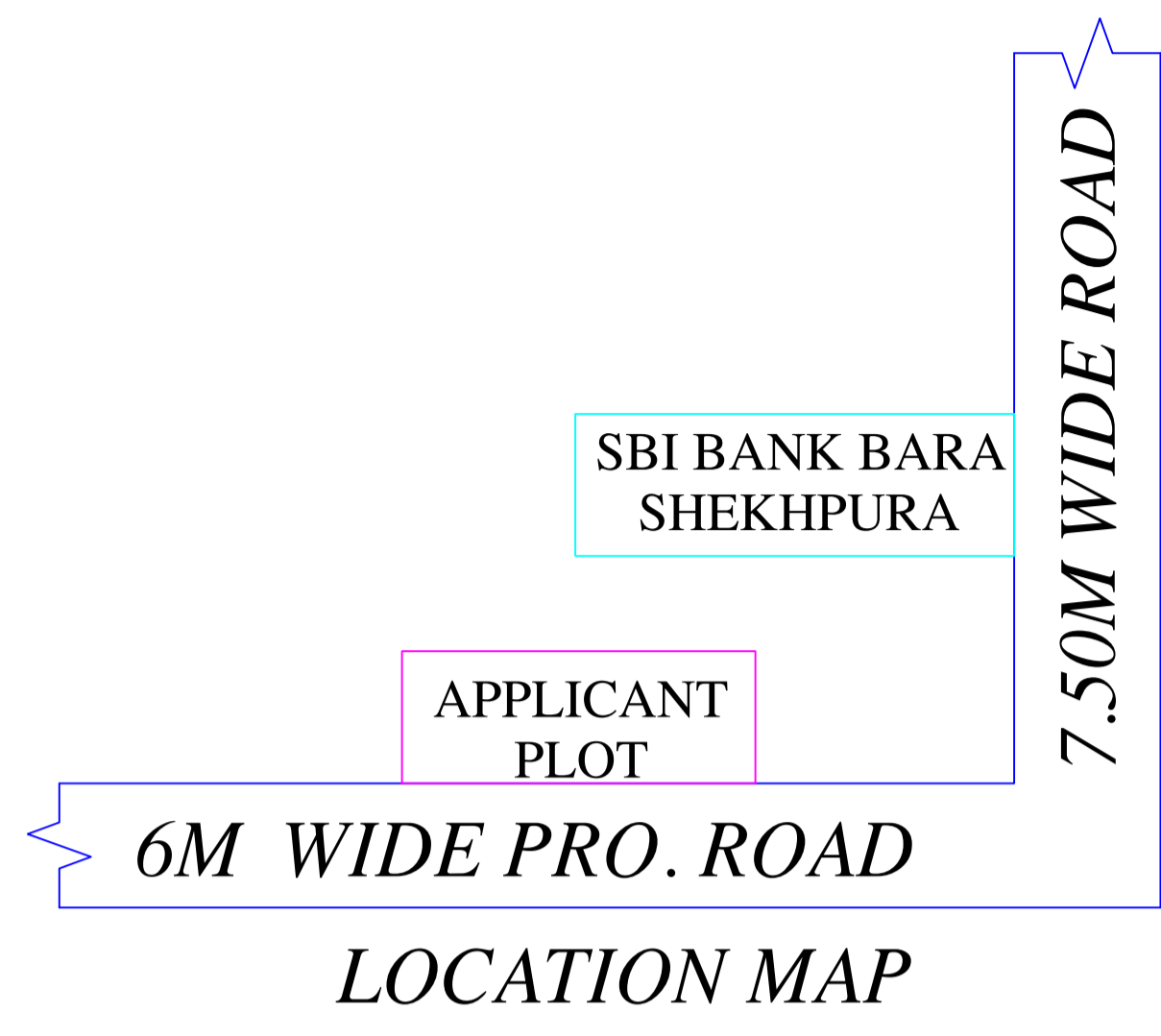

LOCATION MAP

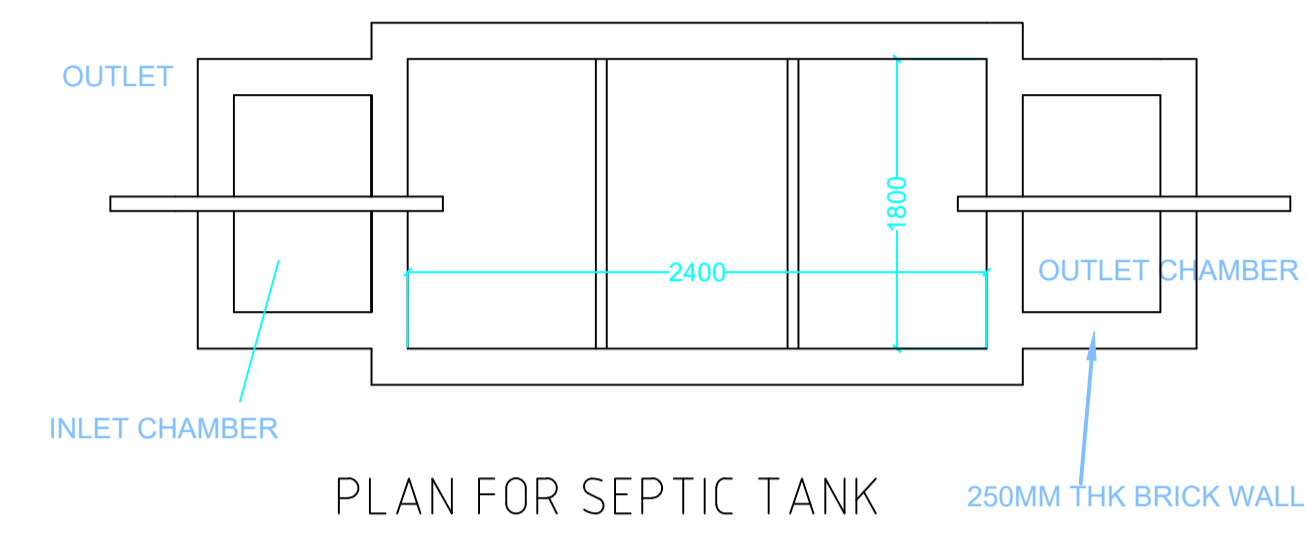

PLAN FOR SEPTIC TANK

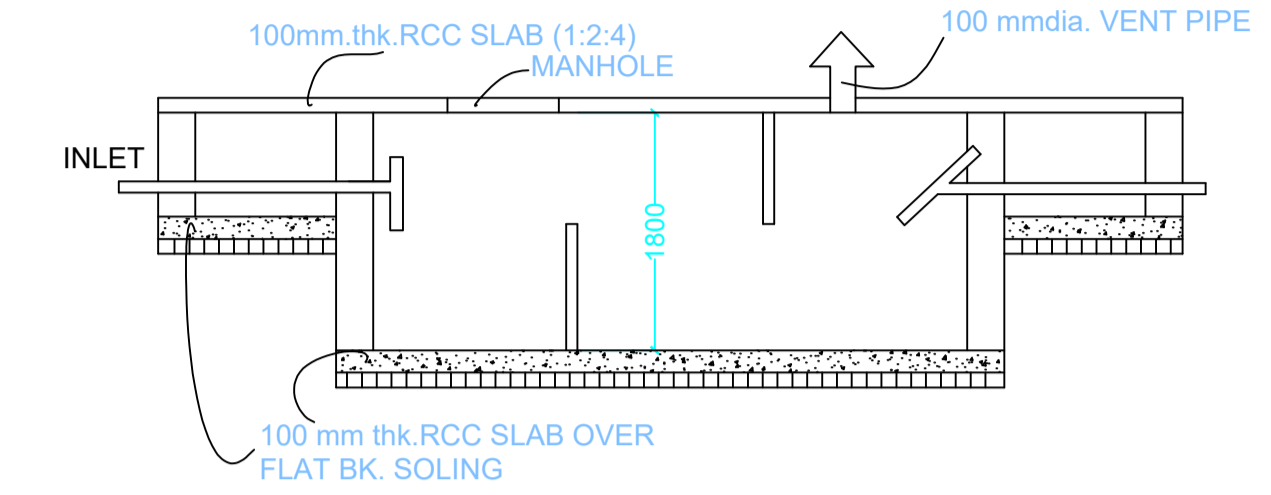

SECTION SCALE 1:50 SEPTIC TANK DETAILS

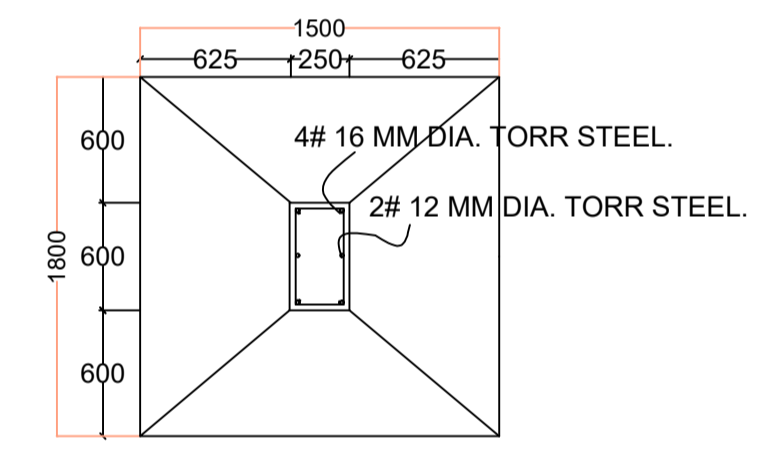

PLAN

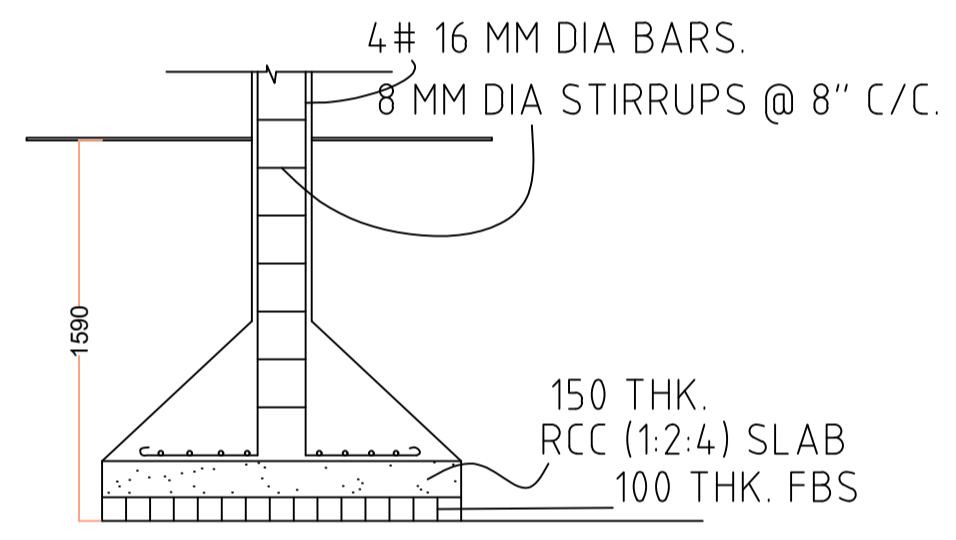

SECTION

FOUNDATION DETAILS (ISOLATED R.C.C FOOTING)

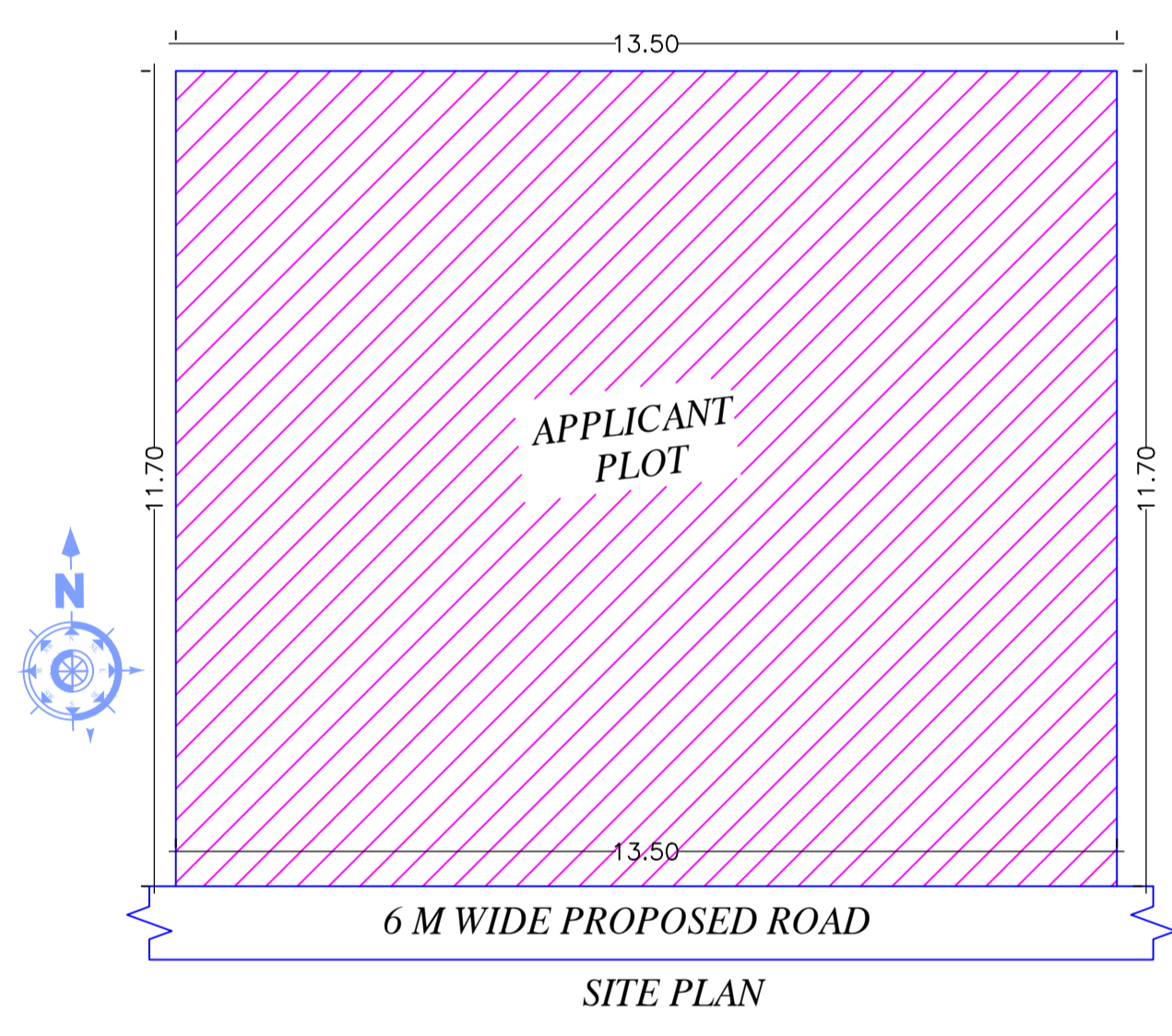

SITE PLAN

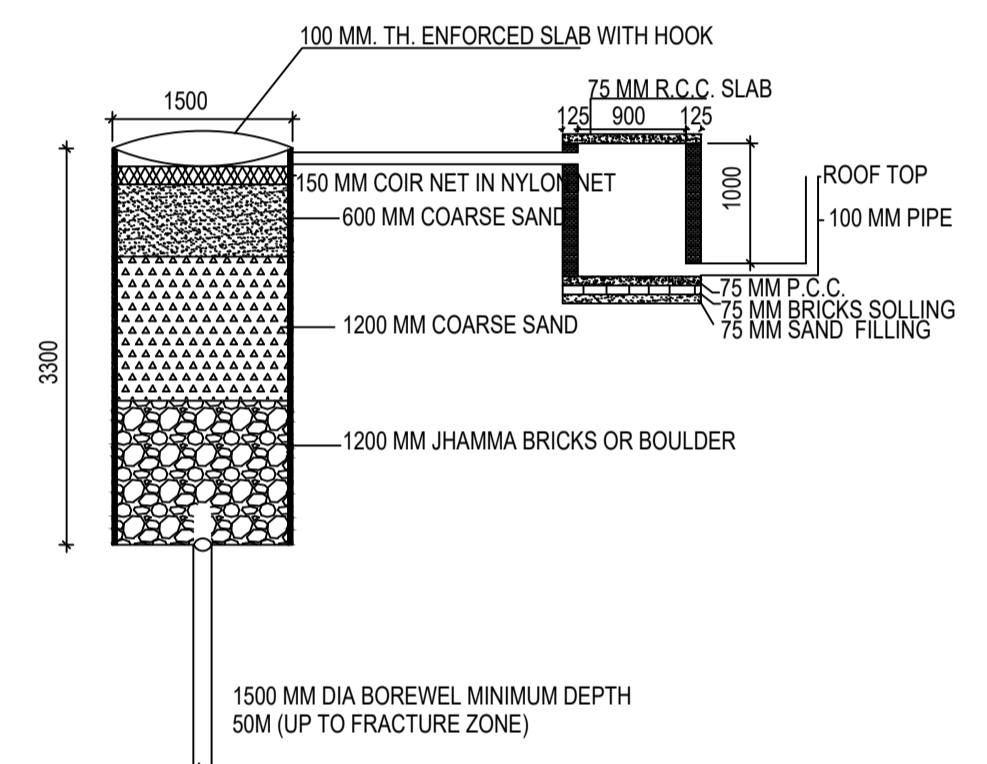

DETAIL OF GROUND WATER RECHARGING PIT WITH SILT TANK SCALE - N.T.S.



FRONT ELEVATION

This is certify that the structure design is in accordance with the latest I-S code(I-S 875,I-S456-2002, I-S 1893-2000) for design & loading conditions (Seismic/wind/dead/live) and other all parameters are taken in account for safetyof the structure.

LTP NAME AND SIGNATURE	STRUCTURAL ENG'S NAME AND SIGNATURE	BUILDER NAME AND SIGNATURE	DIGITAL SIGNATURE
RAJKISHOR KUMAR MNP/ENG/0003/2018			