

Proposal Basic Information	
Proposal File No.	MNP/IBP/0009/W06/2022
Owner Name	SAHJAHAN BIBI
Khata No	95/B
Plot No	05
Village Name	Patharchptti
Use	Residential
SubUse	Bungalow/ Dwelling / Non Apartment

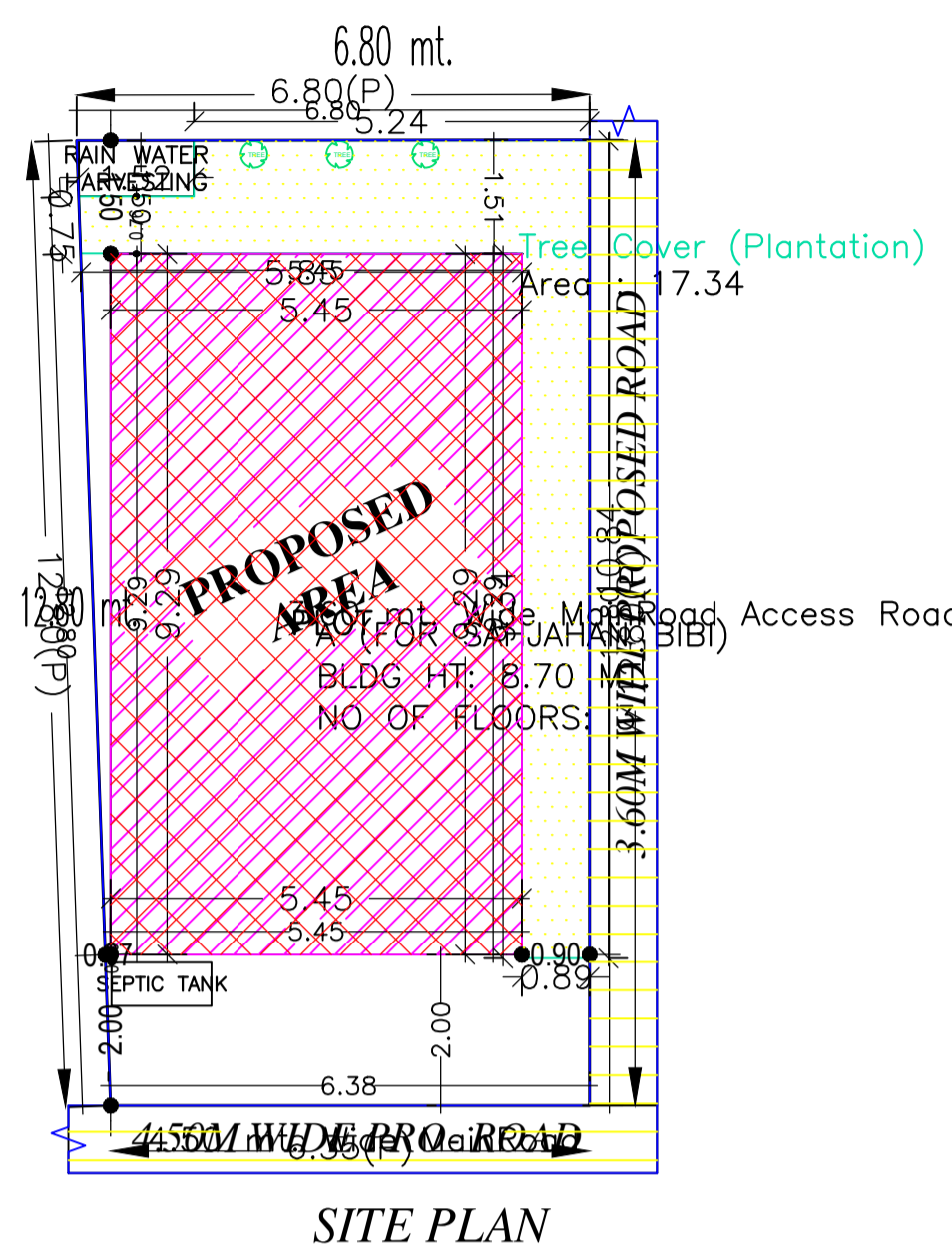

SITE PLAN

SITE PLAN

AREA STATEMENT	VERSION NO.: 1.0.62
MADHUPUR NAGAR	VERSION DATE: 16/10/2020
PARISHAD	
PROJECT DETAIL:	
Region: JHARKHAND URBAN LOCAL BODIES	Plot Use: Residential
District: DEOGHAR	Plot SubUse: Bungalow/ Dwelling / Non Apartment
Authority: MADHUPUR NAGAR PARISHAD	PlotNearby/ReligiousStructure: NA
Inward No: MNP/IBP/0009/W06/2022	Plot/SubPlot No: 05
Application Type: General Proposal	North: Road Width - 4.50
Project Type: Building Permission	South: Plot No. - LAND OF MADRSA ISLAMIYA BUILDING
Nature of Development: New	East: Plot No. - LAND ABDUL ALIM AND BROTHER
Location of Development Area: Old Area	West: Plot No. - LAND OF JMIL AKHTER
AREA DETAILS:	
AREA OF PLOT (Minimum)	(A) 84.13
NET AREA OF PLOT(Gross Plot Area - Deduction from Gross Plot area)	(A-Deductions) 84.13
Deduction for Balance Plot Area(from Gross Plot Area)	
Common Plot	17.34
Total	17.34
BALANCE AREA OF PLOT(Net Plot Area - Recreational/Amenity space)	(A-Deductions) 66.79
PLOT AREA FOR COVERAGE(Net Plot Area)	(A-Deductions) 84.13
Plot Area for FAR (Net Plot Area + RoadWidening Area)	(A-Deductions) 84.13
COVERAGE CHECK	
Permissible Coverage area ( 70.00 % )	58.89
Proposed Coverage Area ( 60.19 % )	50.64
Total Prop. Coverage Area ( 60.19 % )	50.64
Balance coverage area ( 9.81 % )	8.25
FAR CHECK	
Perm. FAR Area ( 1.50 )	126.19
Total Perm. FAR area	126.19
Residential FAR	101.28
Proposed FAR Area	110.63
Total Proposed FAR Area	110.63
Consumed FAR (Factor)	1.31
Balance FAR Area	15.56
BUILT UP AREA CHECK	
Total Proposed BuiltUp Area	151.92
ARCHITECT (Regd)	RAKISHOR KUMAR
ENGINEER (Regd)	
SUPERVISOR (Regd)	
OWNER (Regd)	SAHJAHAN BIBI
DEVELOPMENT AUTHORITY	LOCAL BODY

FAR & Tenement Details (Table 4c-1)

Building	No. of Same Bldg	Total Built Up Area (Sq.mt.)	Deductions (Area in Sq.mt.)	Proposed FAR Area (Sq.mt.)	Add Area In FAR (Sq.mt.)	Total FAR Area (Sq.mt.)	Total Consumed Additional FAR Area (Sq.mt.)	Tnmt (No.)
A (FOR SAHJAHAN BIBI)	1	151.92	41.29	101.28	9.35	110.63	110.63	01
Grand Total :	1	151.92	41.29	101.28	9.35	110.63	110.63	01

Buildingwise Floor FAR Details

Floor Name	Building Name A (FOR SAHJAHAN BIBI)		Total	
	Proposed Built Up Area (Sq.mt.)	Proposed FAR Area (Sq.mt.)	Total Proposed Built Up Area (Sq.mt.)	Total FAR Area (Sq.mt.)
Ground Floor	50.64	9.35	50.64	9.35
First Floor	50.64	50.64	50.64	50.64
Second Floor	50.64	50.64	50.64	50.64
Terrace Floor	0.00	0.00	0.00	0.00
Total :	151.92	110.63	151.92	110.63

Building USE/SUBUSE Details

Building Name	Building Use	Building SubUse	Building Structure
A (FOR SAHJAHAN BIBI)	Residential	Bungalow/ Dwelling / Non Apartment	Non-Highrise

COLOR INDEX	
PLOT BOUNDARY	
ABUTTING ROAD	
PROPOSED CONSTRUCTION	
COMMON PLOT	
ROAD WIDENING AREA	
EXISTING (To be retained)	
EXISTING (To be demolished)	

LTP NAME AND SIGNATURE	STRUCTURAL ENG'S NAME AND SIGNATURE	BUILDER NAME AND SIGNATURE	DIGITAL SIGNATURE
RAKISHOR KUMAR MNP/ENG/0003/2018			

Proposal Basic Information	
Proposal File No.	MNP/IB/0009/W06/2022
Owner Name	SAHJAHAN BIBI
Khata No	95/B
Plot No	05
Village Name	Patharchptti
Use	Residential
SubUse	Bungalow/ Dwelling / Non Apartment

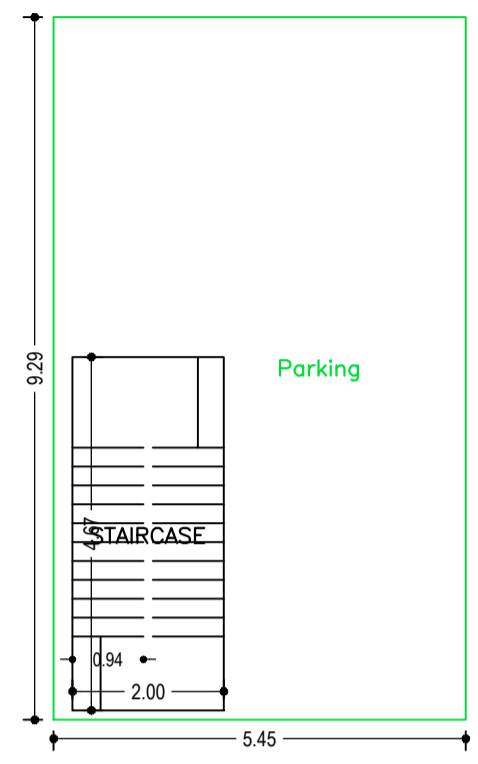

GROUND FLOOR PLAN  
(SCALE 1:100)

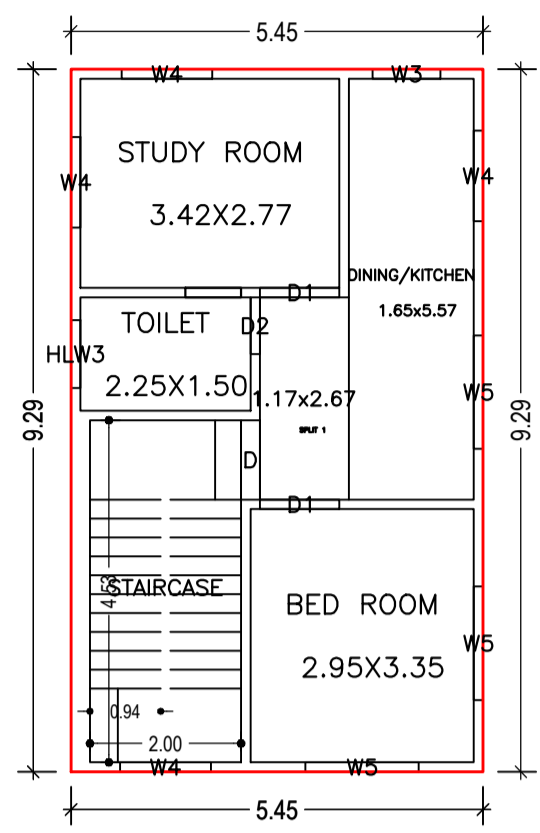

FIRST FLOOR PLAN  
(Proposed)  
(SCALE 1:100)

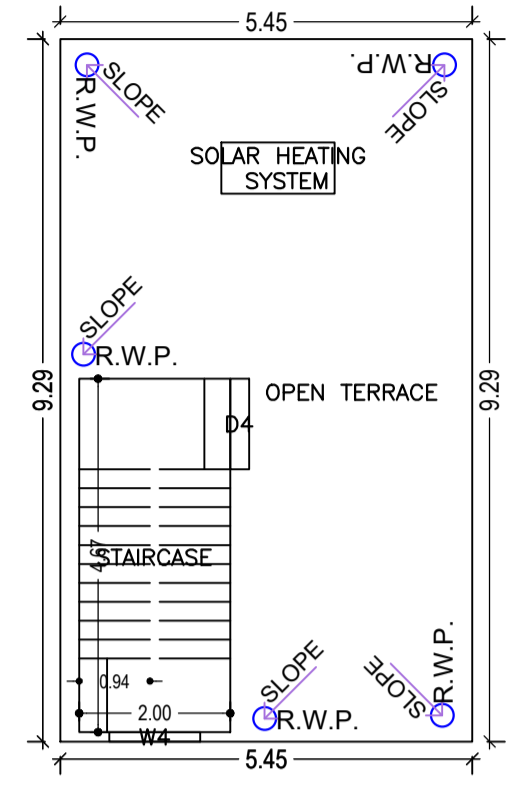

TERRACE FLOOR PLAN  
(SCALE 1:100)

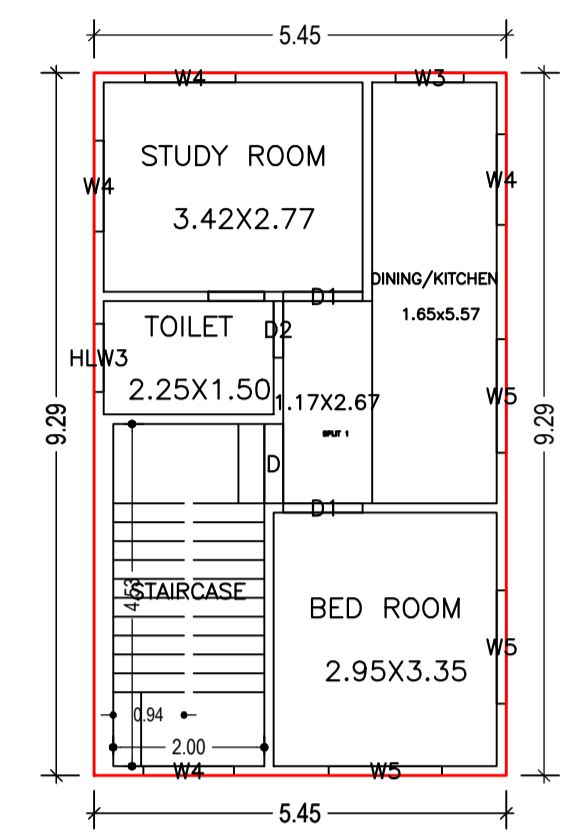

SECOND FLOOR PLAN  
(Proposed)  
(SCALE 1:100)

UnitBUA Table for Building :A (FOR SAHJAHAN BIBI)

FLOOR	Name	UnitBUA Type	UnitBUA Area	Carpet Area	No. of Rooms	No. of Tenement
FIRST FLOOR PLAN	SPLIT 1	FLAT	74.81	74.62	4	1
SECOND FLOOR PLAN	SPLIT 1	FLAT	0.00	0.00	4	0
Total:	-	-	74.81	74.62	8	1

SCHEDULE OF DOOR:

BUILDING NAME	NAME	LENGTH	HEIGHT	NOS
A (FOR SAHJAHAN BIBI)	D2	0.75	2.10	02
A (FOR SAHJAHAN BIBI)	D1	1.05	2.10	04
A (FOR SAHJAHAN BIBI)	D	1.05	2.10	02

SCHEDULE OF WINDOW/VENTILATION:

BUILDING NAME	NAME	LENGTH	HEIGHT	NOS
A (FOR SAHJAHAN BIBI)	HLW3	0.90	0.80	02
A (FOR SAHJAHAN BIBI)	W3	0.90	1.35	02
A (FOR SAHJAHAN BIBI)	W4	1.20	1.35	09
A (FOR SAHJAHAN BIBI)	W5	1.50	1.35	06

Building :A (FOR SAHJAHAN BIBI)

Floor Name	Total Built Up Area (Sq.mt.)	Deductions (Area in Sq.mt.)	Proposed FAR Area (Sq.mt.)		Add Area In FAR (Sq.mt.)	Total FAR Area (Sq.mt.)	Total Consumed Additional FAR Area (Sq.mt.)	Tnmt (No.)
			Parking	Resi.				
Ground Floor	50.64	41.29	0.00	9.35	9.35	9.35	9.35	00
First Floor	50.64	0.00	50.64	0.00	50.64	50.64	50.64	01
Second Floor	50.64	0.00	50.64	0.00	50.64	50.64	50.64	00
Terrace Floor	0.00	0.00	0.00	0.00	0.00	0.00	0.00	00
Total :	151.92	41.29	101.28	9.35	110.63	110.63	110.63	01
Total Number of Same Buildings :	1							
Total :	151.92	41.29	101.28	9.35	110.63	110.63	110.63	01

LTP NAME AND SIGNATURE	STRUCTURAL ENG'S NAME AND SIGNATURE	BUILDER NAME AND SIGNATURE	DIGITAL SIGNATURE
RAJKISHOR KUMAR MNP/ENG/0003/2018			

		DATE	12-03-2022
Proposal Basic Information		SHEET NO.	3
Proposal File No.	MNP/IB/0009/W06/2022		
Owner Name	SAHJAHAN BIBI		
Khata No	95/B		
Plot No	05		
Village Name	Patharchpotti		
Use	Residential		
SubUse	Bungalow/ Dwelling / Non Apartment		

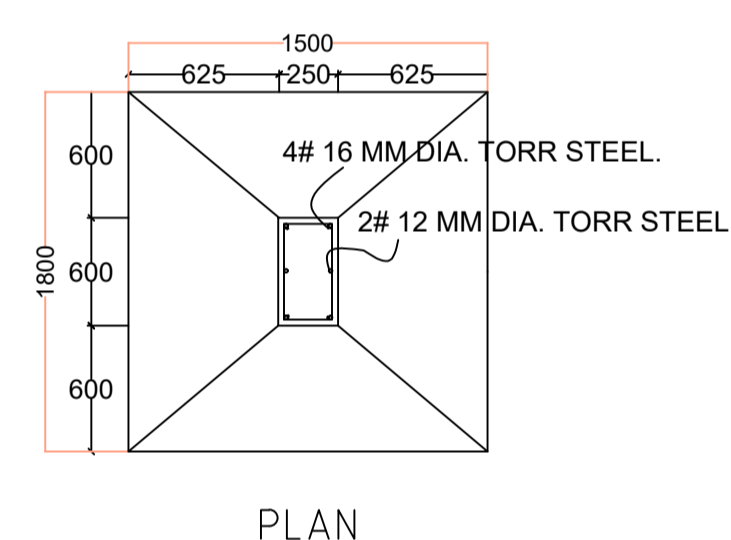
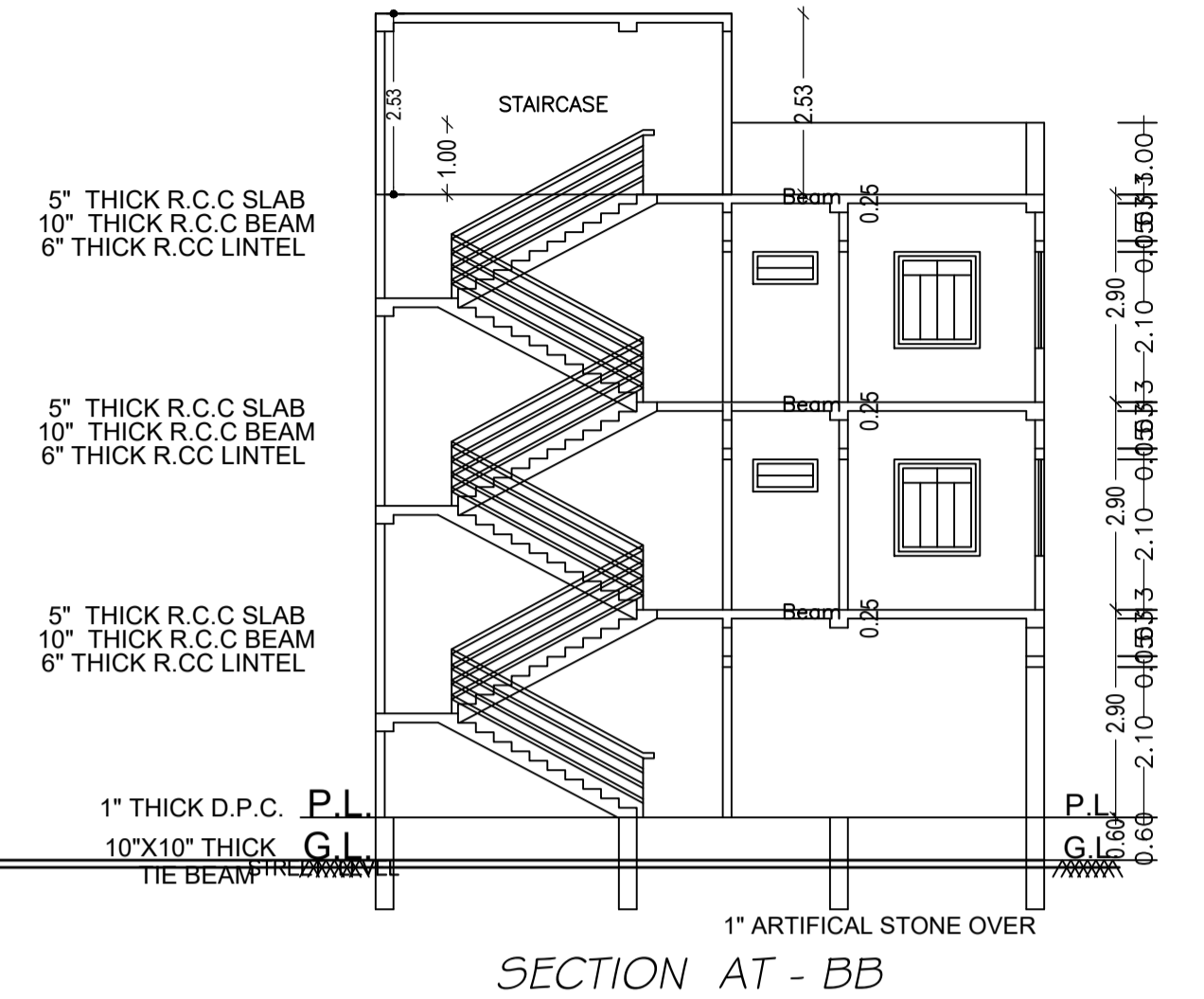
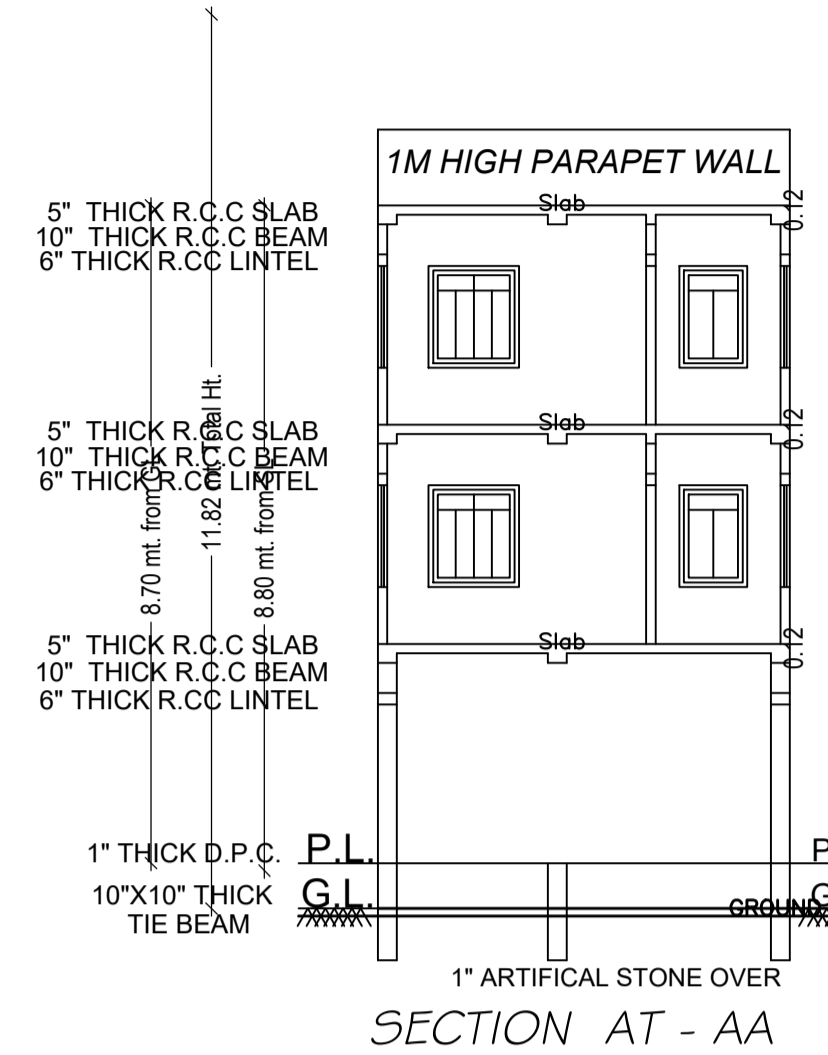
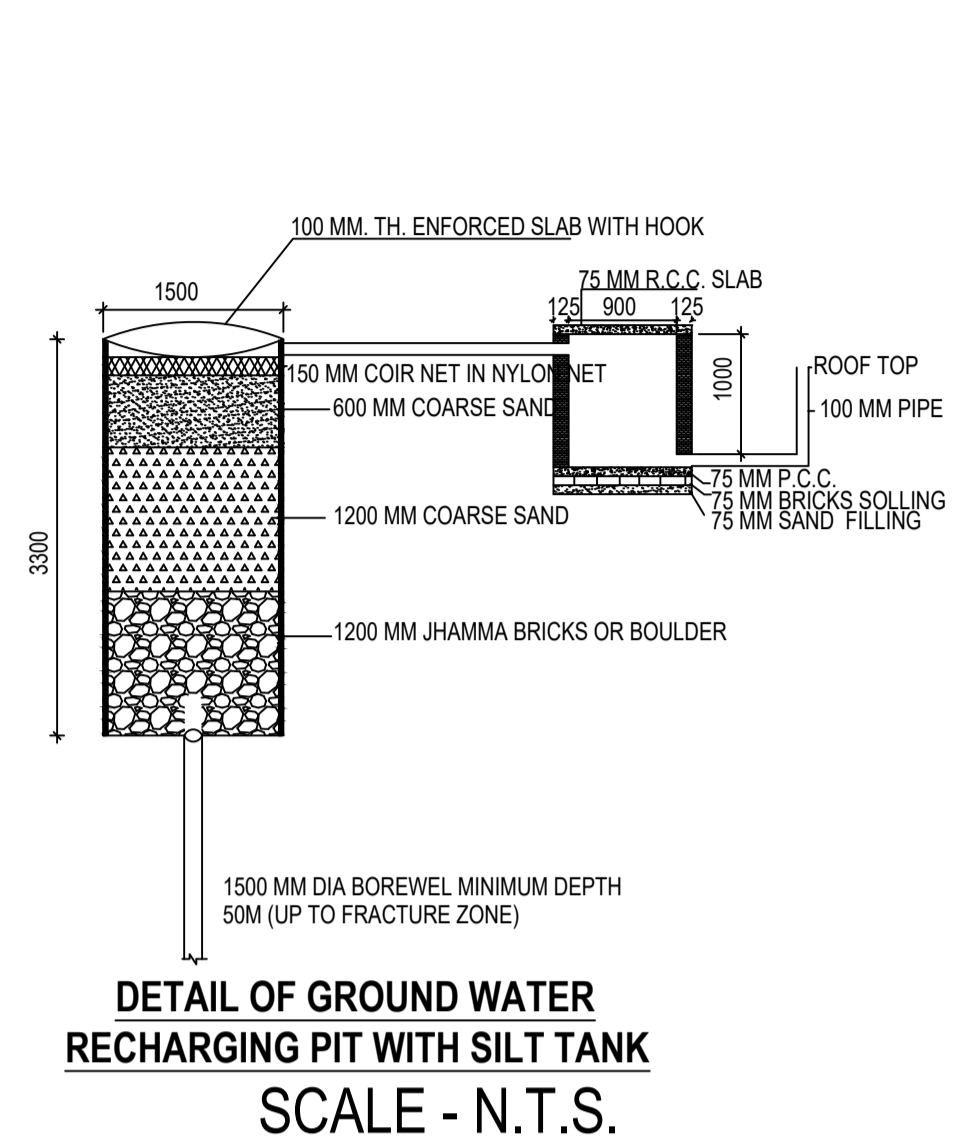
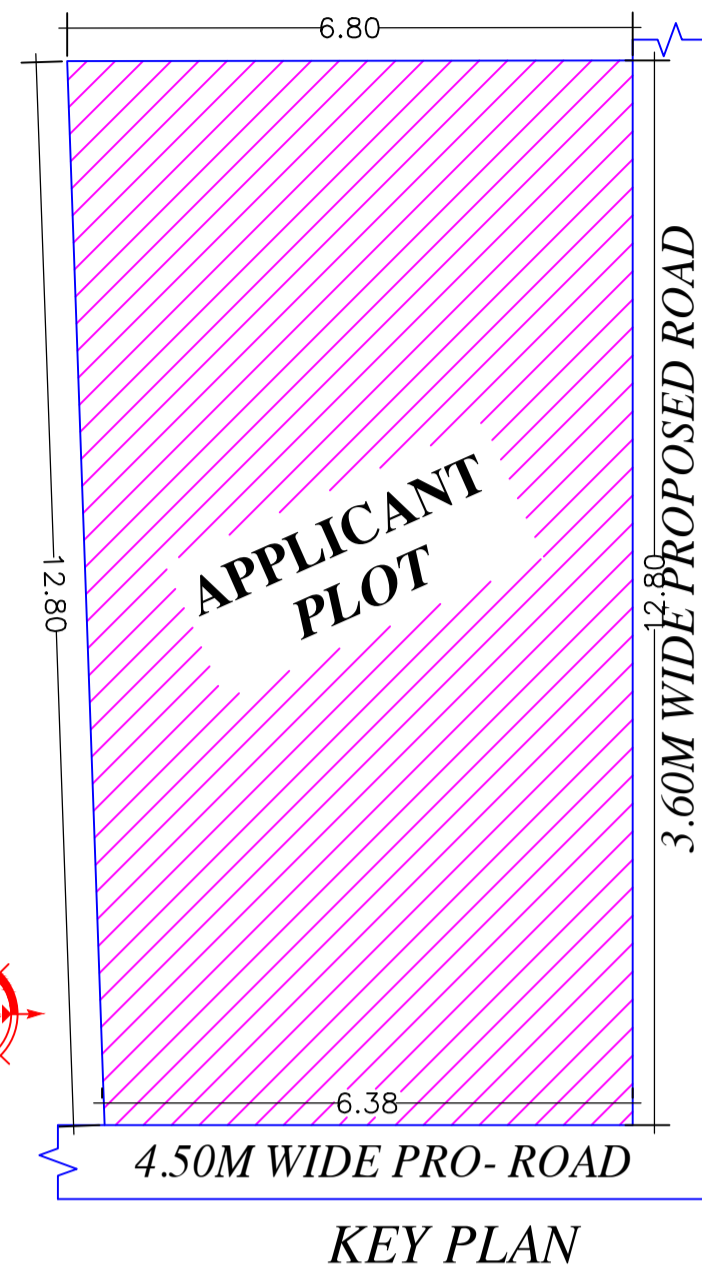

FOUNDATION DETAILS (ISOLATED R.C.C FOOTING)

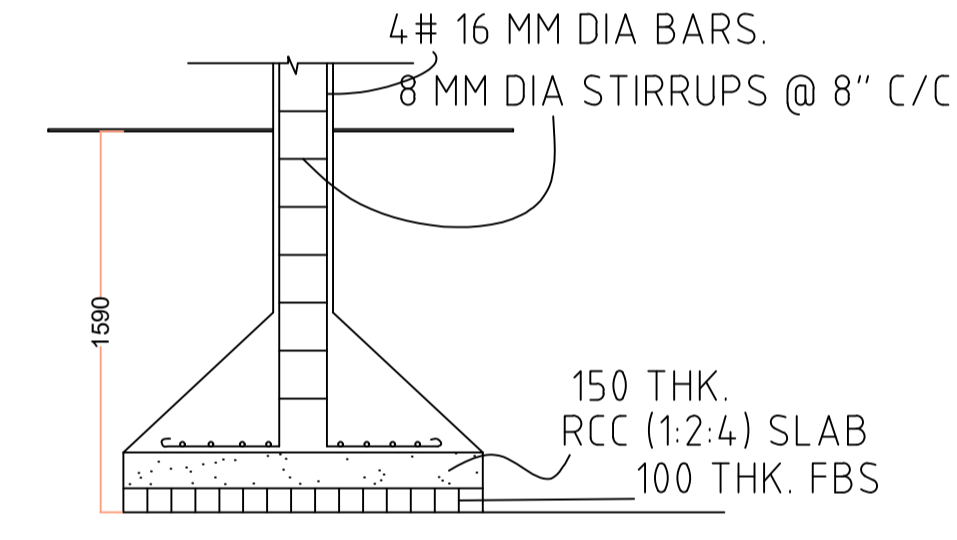

SECTION

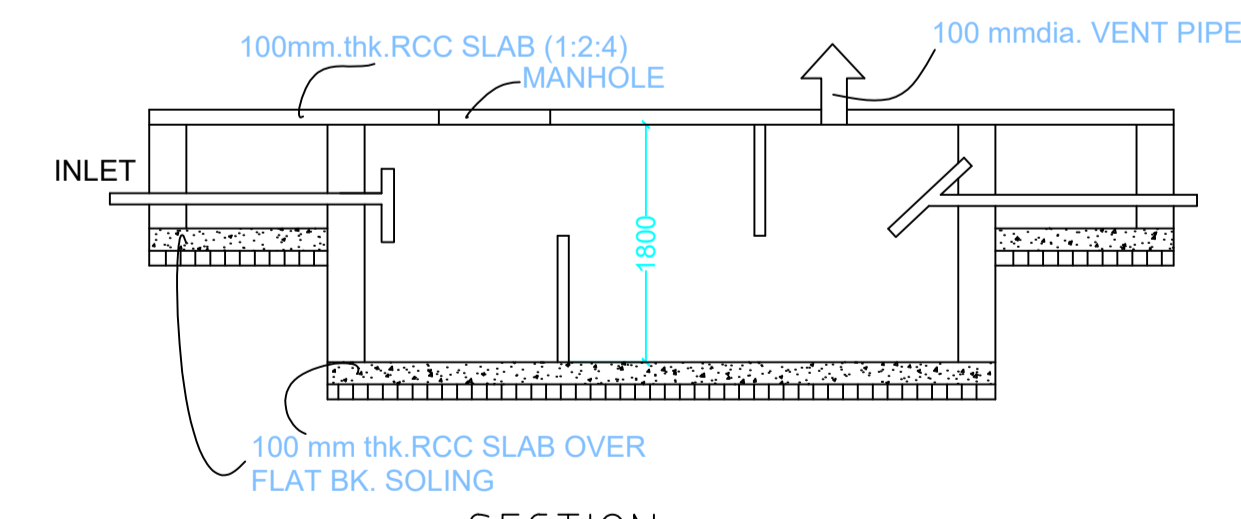
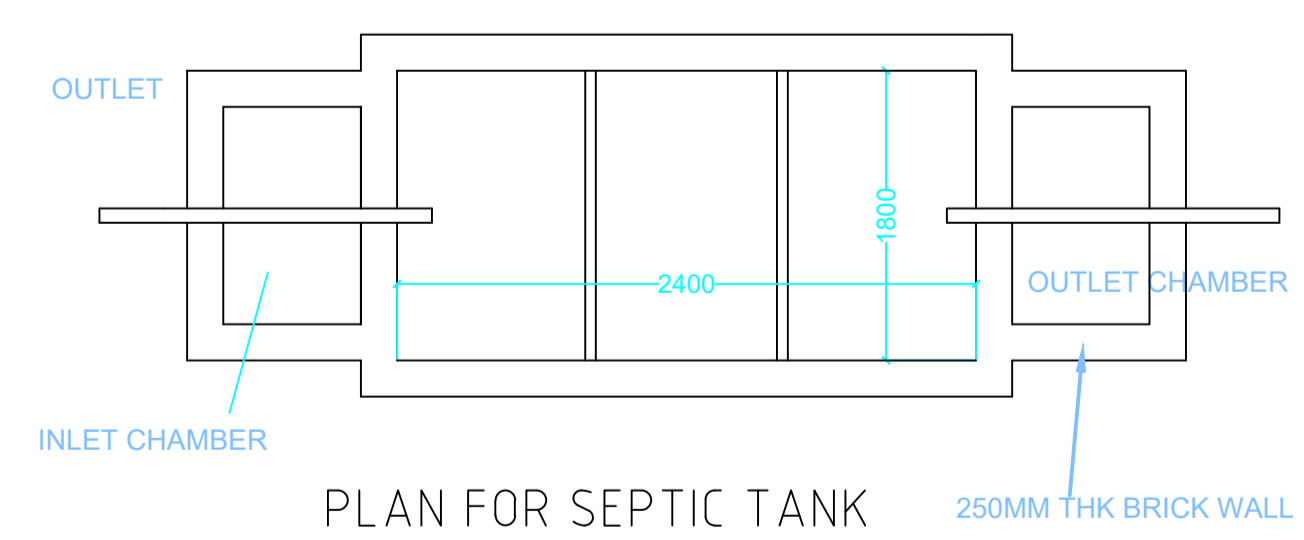
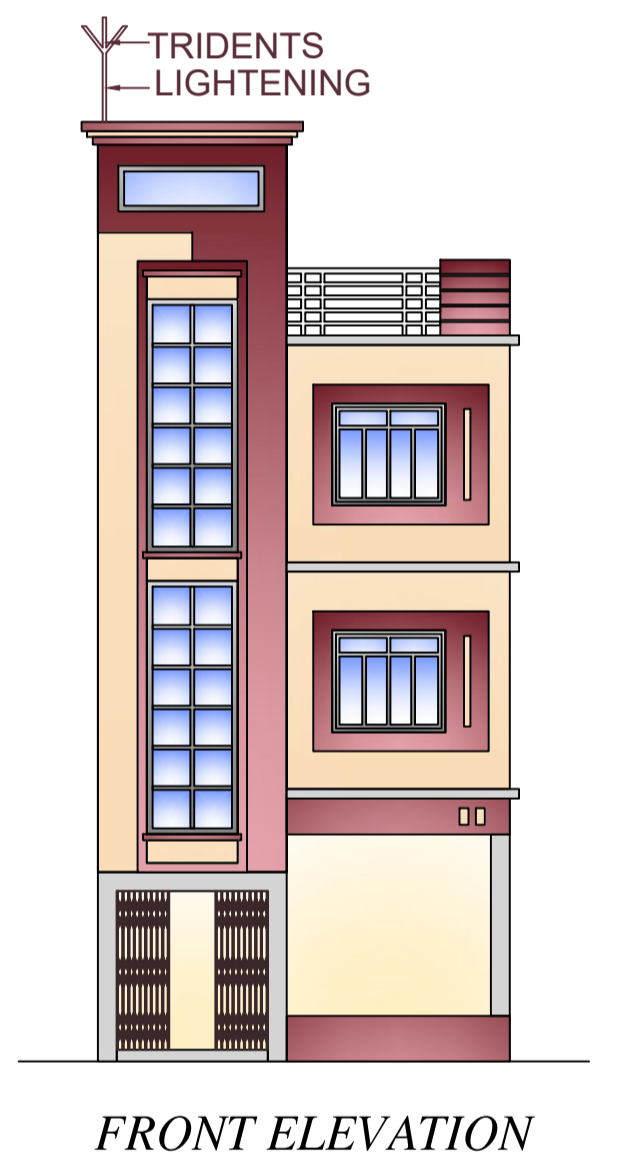
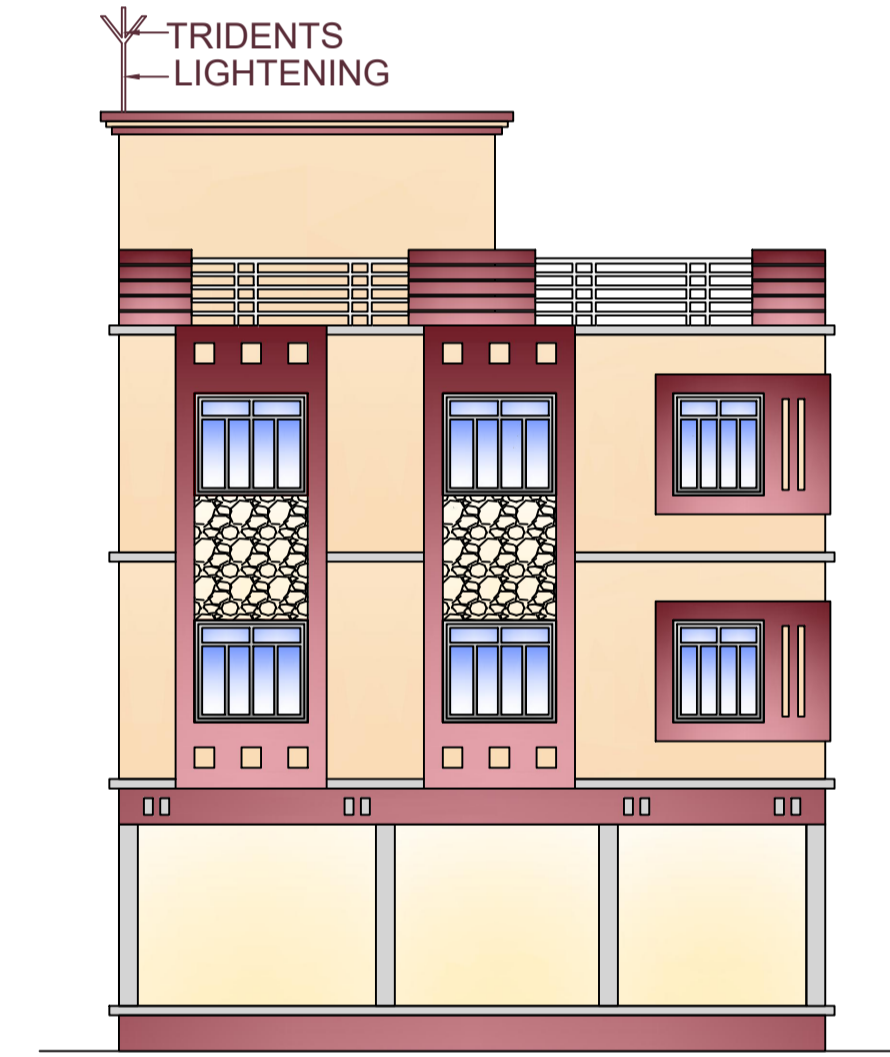
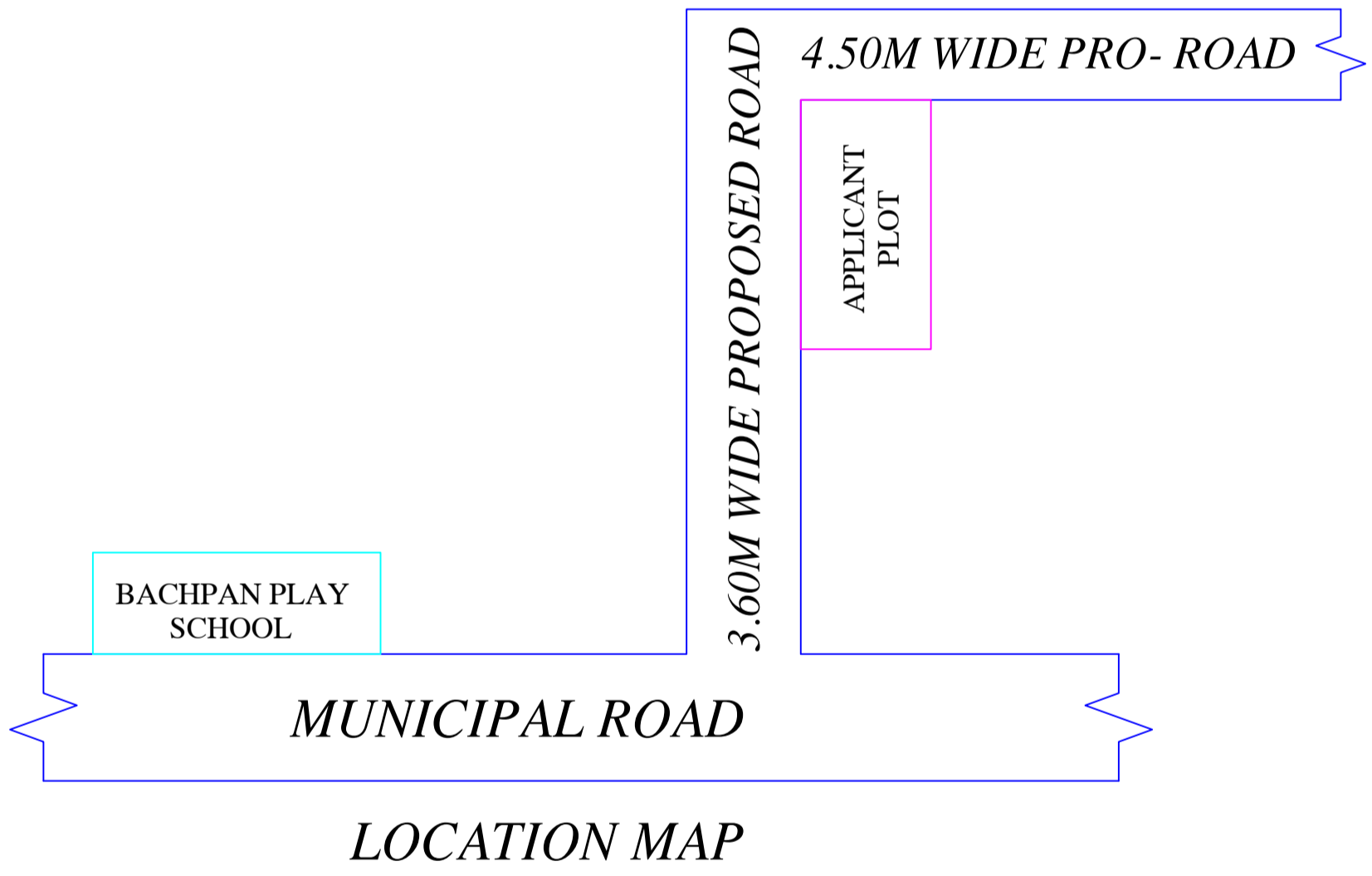

SECTION SCALE 1:50  
SEPTIC TANK DETAILS

This is certify that the structure design is in accordance with the latest I-S code(I-S 875,I-S456-2002, I-S 1893-2000) for design & loading conditions (Sessmic/wnd/dead/live) and other all parameters are taken in account for safetyof the structure.

LTP NAME AND SIGNATURE	STRUCTURAL ENG'S NAME AND SIGNATURE	BUILDER NAME AND SIGNATURE	DIGITAL SIGNATURE
RAJKISHOR KUMAR MNP/ENG/0003/2018			