

SITE PLAN

SITE PLAN

Proposal Basic Information	
Proposal File No.	MNP/BI/0044/W21/2022
Owner Name	SHAHNAZ PARVEEN
Khata No	146
Plot No	NA
Village Name	Patharchptti
Use	Residential
SubUse	Bungalow/ Dwelling / Non Apartment

FAR & Tenement Details (Table 4c-1)

Building	No. of Same Bldg	Total Built Up Area (Sq.mt.)	Proposed FAR Area (Sq.mt.) Resi.	Total FAR Area (Sq.mt.)	Total Consumed Additional FAR Area (Sq.mt.)	Tnmt (No.)
A (SHAHNAZ PARVEEN)	1	241.92	241.92	241.92	241.92	01
Grand Total :	1	241.92	241.92	241.92	241.92	01

Buildingwise Floor FAR Details

Floor Name	Building Name A (SHAHNAZ PARVEEN)		Total	
	Proposed Built Up Area (Sq.mt.)	Proposed FAR Area (Sq.mt.)	Total Proposed Built Up Area (Sq.mt.)	Total FAR Area (Sq.mt.)
Ground Floor	120.96	120.96	120.96	120.96
First Floor	120.96	120.96	120.96	120.96
Terrace Floor	0.00	0.00	0.00	0.00
Total :	241.92	241.92	241.92	241.92

COLOR INDEX	
PLOT BOUNDARY	Black
ABUTTING ROAD	Green
PROPOSED CONSTRUCTION	Red
COMMON PLOT	Yellow
ROAD WIDENING AREA	Blue
EXISTING (To be retained)	Light Blue
EXISTING (To be demolished)	Light Yellow

Building USE/SUBUSE Details

Building Name	Building Use	Building SubUse	Building Structure
A (SHAHNAZ PARVEEN)	Residential	Bungalow/ Dwelling / Non Apartment	Non-Highrise

AREA STATEMENT	VERSION NO.: 1.0.62
MADHUPUR NAGAR	VERSION DATE: 16/10/2020
PARISHAD	
PROJECT DETAIL:	
Region: JHARKHAND URBAN LOCAL BODIES	Plot Use: Residential
District: DEOGHAR	Plot SubUse: Bungalow/ Dwelling / Non Apartment
Authority: MADHUPUR NAGAR PARISHAD	PlotNearbyReligiousStructure: NA
Inward No: MNP/BI/0044/W21/2022	Plot/SubPlot No: NA
Application Type: General Proposal	North: Plot No. - VENDORS LAND
Project Type: Building Permission	South: Plot No. - VENDORS LAND
Nature of Development: New	East: Road Width - 3.6
Location of Development Area: Old Area	West: Plot No. - DINA LODGE
AREA DETAILS:	
AREA OF PLOT (Minimum)	(A) 207.00 SQ.MT.
NET AREA OF PLOT(Gross Plot Area - Deduction from Gross Plot area)	(A-Deductions) 207.00
Deduction for Balance Plot Area(from Gross Plot Area)	
Common Plot	41.31
Total	41.31
BALANCE AREA OF PLOT(Net Plot Area - Recreational/Amenity space)	(A-Deductions) 165.69
PLOT AREA FOR COVERAGE(Net Plot Area)	(A-Deductions) 207.00
Plot Area for FAR (Net Plot Area + RoadWidening Area)	(A-Deductions) 207.00
COVERAGE CHECK	
Permissible Coverage area (70.00 %)	144.90
Proposed Coverage Area (58.43 %)	120.96
Total Prop. Coverage Area (58.43 %)	120.96
Balance coverage area (11.57 %)	23.94
FAR CHECK	
Perm. FAR Area (1.50)	310.50
Total Perm. FAR area	310.50
Residential FAR	241.92
Proposed FAR Area	241.92
Total Proposed FAR Area	241.92
Consumed FAR (Factor)	1.17
Balance FAR Area	68.58
BUILT UP AREA CHECK	
Total Proposed BuiltUp Area	241.92
ARCHITECT (Regd)	RAJKISHOR KUMAR
ENGINEER (Regd)	
SUPERVISOR (Regd)	
OWNER (Regd)	SHAHNAZ PARVEEN
DEVELOPMENT AUTHORITY	
	LOCAL BODY

LTP NAME AND SIGNATURE	STRUCTURAL ENG'S NAME AND SIGNATURE	BUILDER NAME AND SIGNATURE	DIGITAL SIGNATURE
RAJKISHOR KUMAR MNP/ENG/0003/2018			

Proposal Basic Information

Proposal File No.	MNP/EP/0044/W21/2022
Owner Name	SHAHNAZ PARVEEN
Khata No	146
Plot No	NA
Village Name	Patharchptti
Use	Residential
SubUse	Bungalow/ Dwelling / Non Apartment

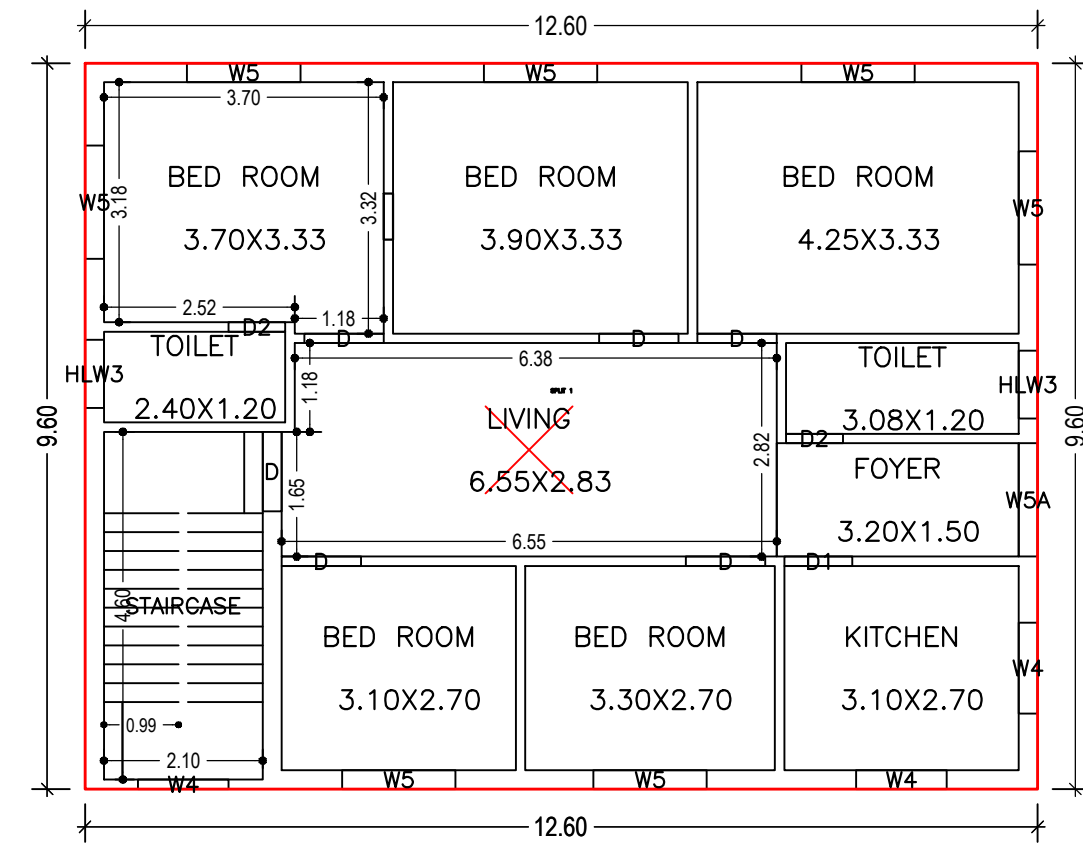

FIRST FLOOR PLAN (Proposed) (SCALE 1:100)

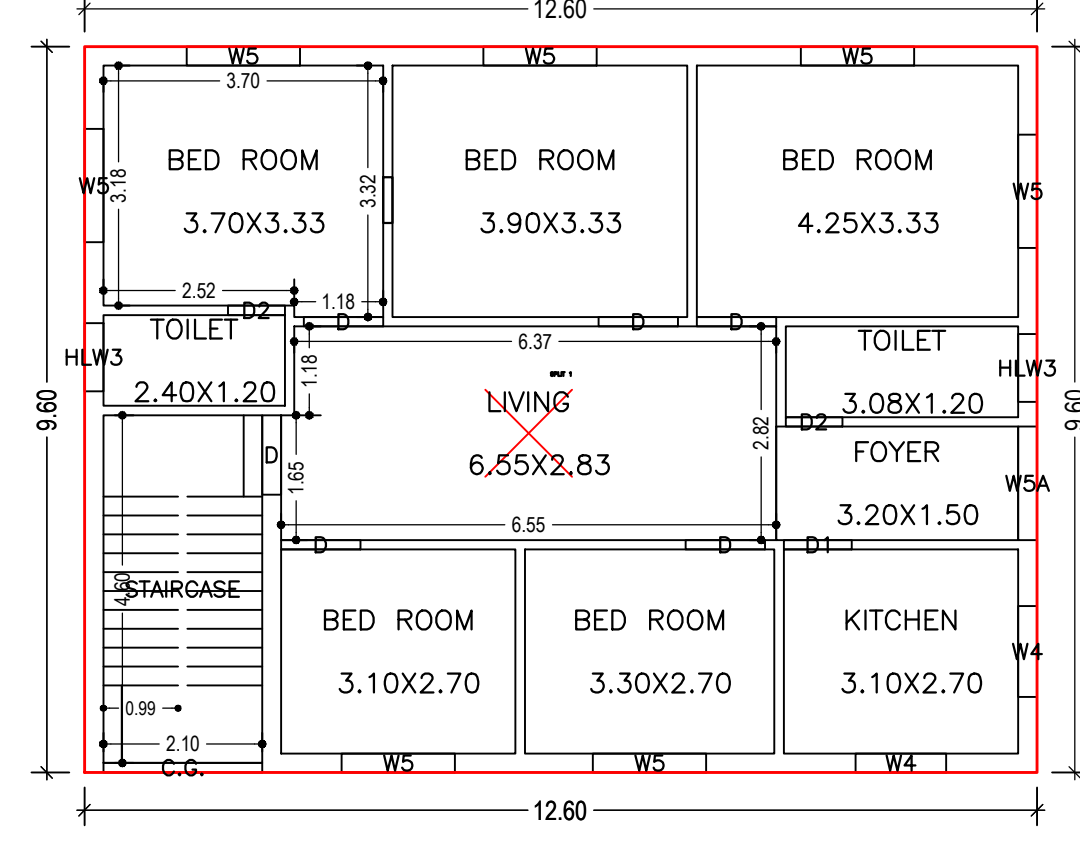

GROUND FLOOR PLAN (Proposed) (SCALE 1:100)

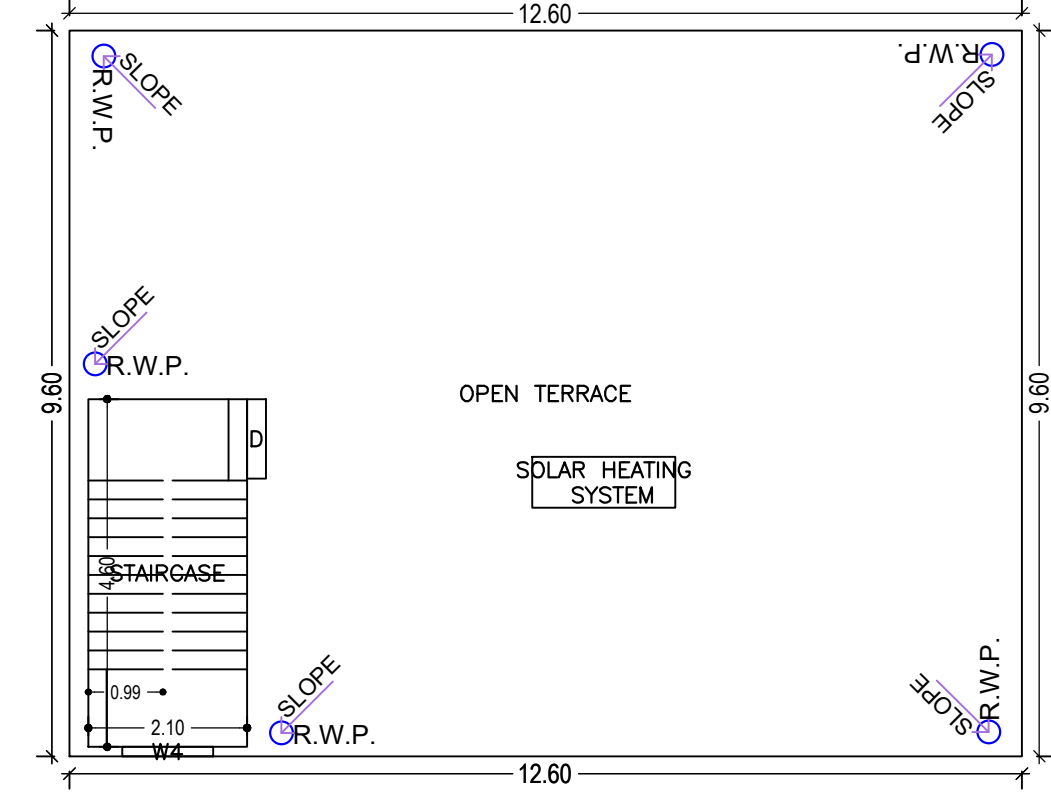

TERRACE FLOOR PLAN (SCALE 1:100)

UnitBUA Table for Building :A (SHAHNAZ PARVEEN)

FLOOR	Name	UnitBUA Type	UnitBUA Area	Carpet Area	No. of Rooms	No. of Tenement
FIRST FLOOR PLAN	SPLIT 1	FLAT	0.00	0.00	10	0
GROUND FLOOR PLAN	SPLIT 1	FLAT	201.43	201.27	10	1
Total:	-	-	201.43	201.27	20	1

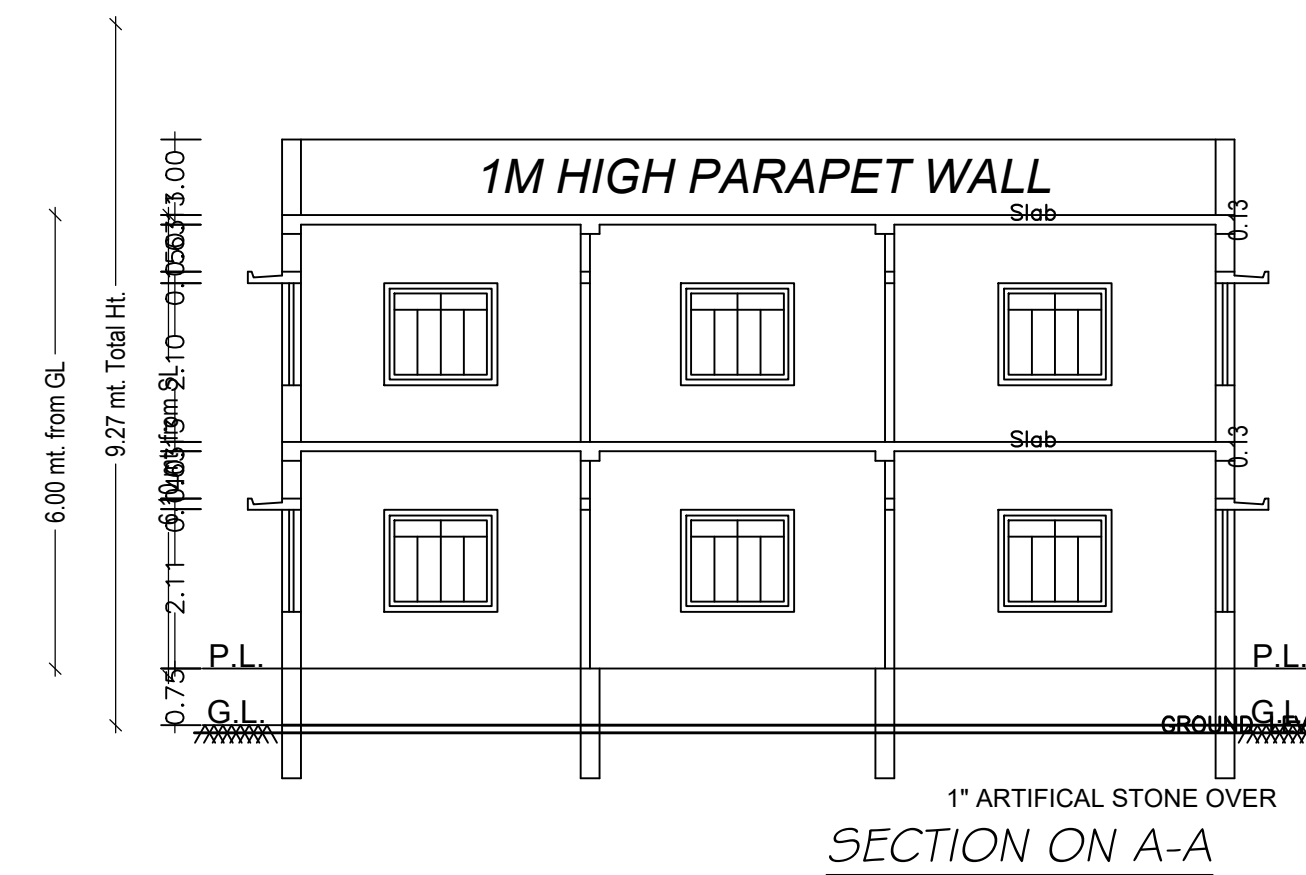

SECTION ON A-A

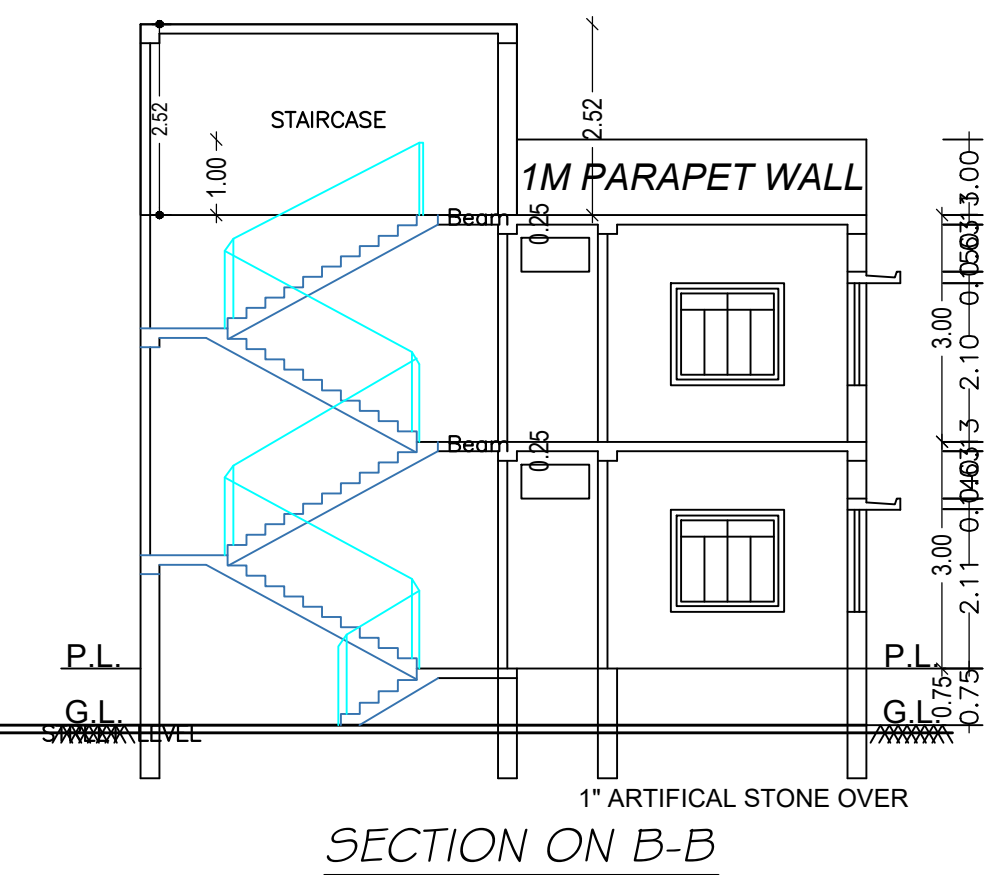

SECTION ON B-B

SCHEDULE OF DOOR:

BUILDING NAME	NAME	LENGTH	HEIGHT	NOS
A (SHAHNAZ PARVEEN)	D2	0.75	2.10	04
A (SHAHNAZ PARVEEN)	D1	0.90	2.10	02
A (SHAHNAZ PARVEEN)	D	1.05	2.10	12

SCHEDULE OF WINDOW/VENTILATION:

BUILDING NAME	NAME	LENGTH	HEIGHT	NOS
A (SHAHNAZ PARVEEN)	HLW3	0.90	0.60	04
A (SHAHNAZ PARVEEN)	W4	1.20	1.35	06
A (SHAHNAZ PARVEEN)	W5	1.50	1.35	14
A (SHAHNAZ PARVEEN)	W5A	1.50	1.80	02

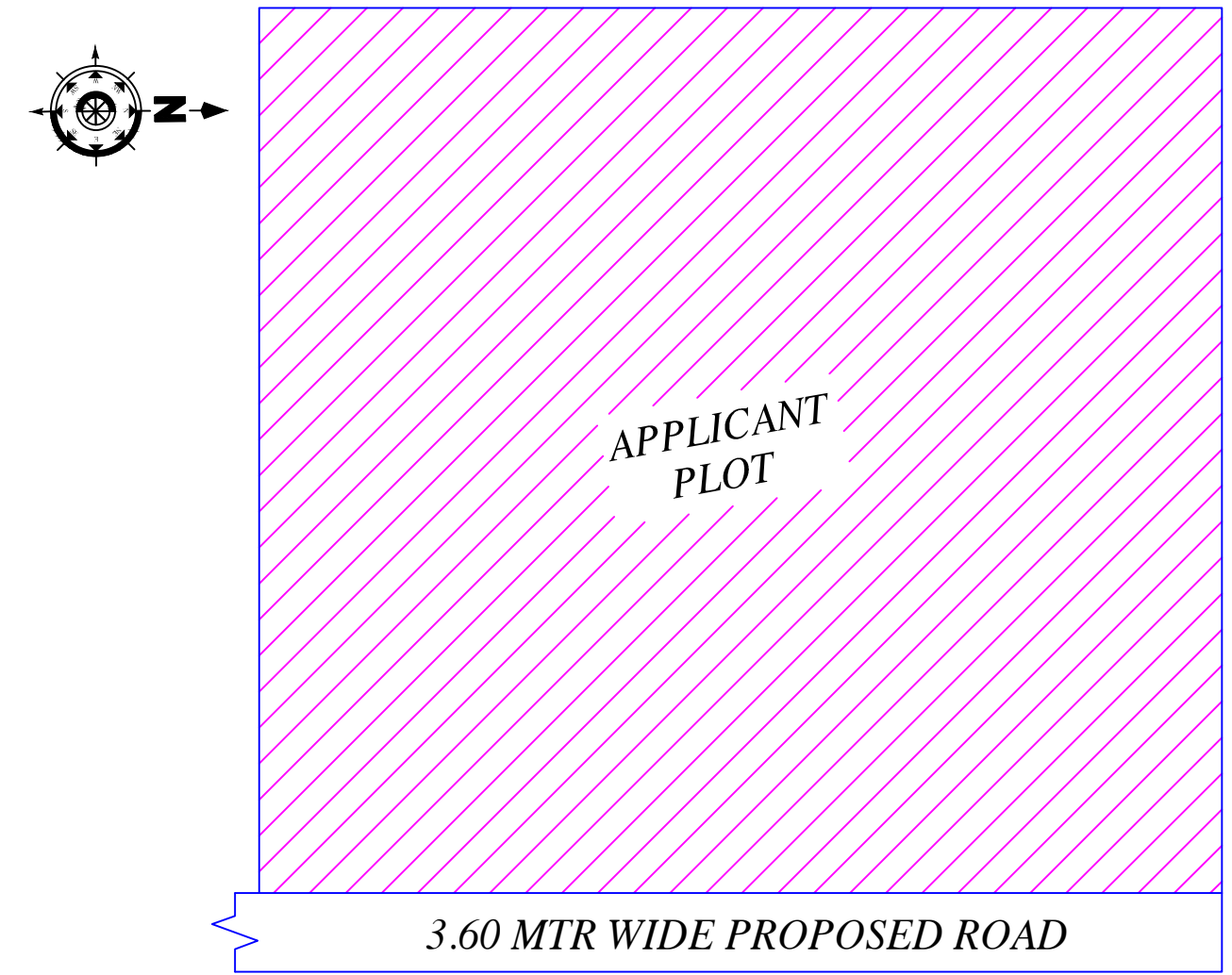

KEY PLAN

Building :A (SHAHNAZ PARVEEN)

Floor Name	Total Built Up Area (Sq.mt.)	Proposed FAR Area (Sq.mt.) Resi.	Total FAR Area (Sq.mt.)	Total Consumed Additional FAR Area (Sq.mt.)	Tnmt (No.)
Ground Floor	120.96	120.96	120.96	120.96	01
First Floor	120.96	120.96	120.96	120.96	00
Terrace Floor	0.00	0.00	0.00	0.00	00
Total :	241.92	241.92	241.92	241.92	01
Total Number of Same Buildings :	1				
Total :	241.92	241.92	241.92	241.92	01

LTP NAME AND SIGNATURE	STRUCTURAL ENG'S NAME AND SIGNATURE	BUILDER NAME AND SIGNATURE	DIGITAL SIGNATURE
RAJKISHOR KUMAR MNP/ENG/0003/2018			

Proposal Basic Information	
Proposal File No.	MNP/BP/0044/W21/2022
Owner Name	SHAHNAZ PARVEEN
Khata No	146
Plot No	NA
Village Name	Patharchptti
Use	Residential
SubUse	Bungalow/ Dwelling / Non Apartment

This is certify that the structure design is in accordance with the latest I-S code(I-S 875,I-S456-2002, I-S 1893-2000) for design & loading conditions (Seismic/wind/dead/live) and other all parameters are taken in account for safetyof the structure.

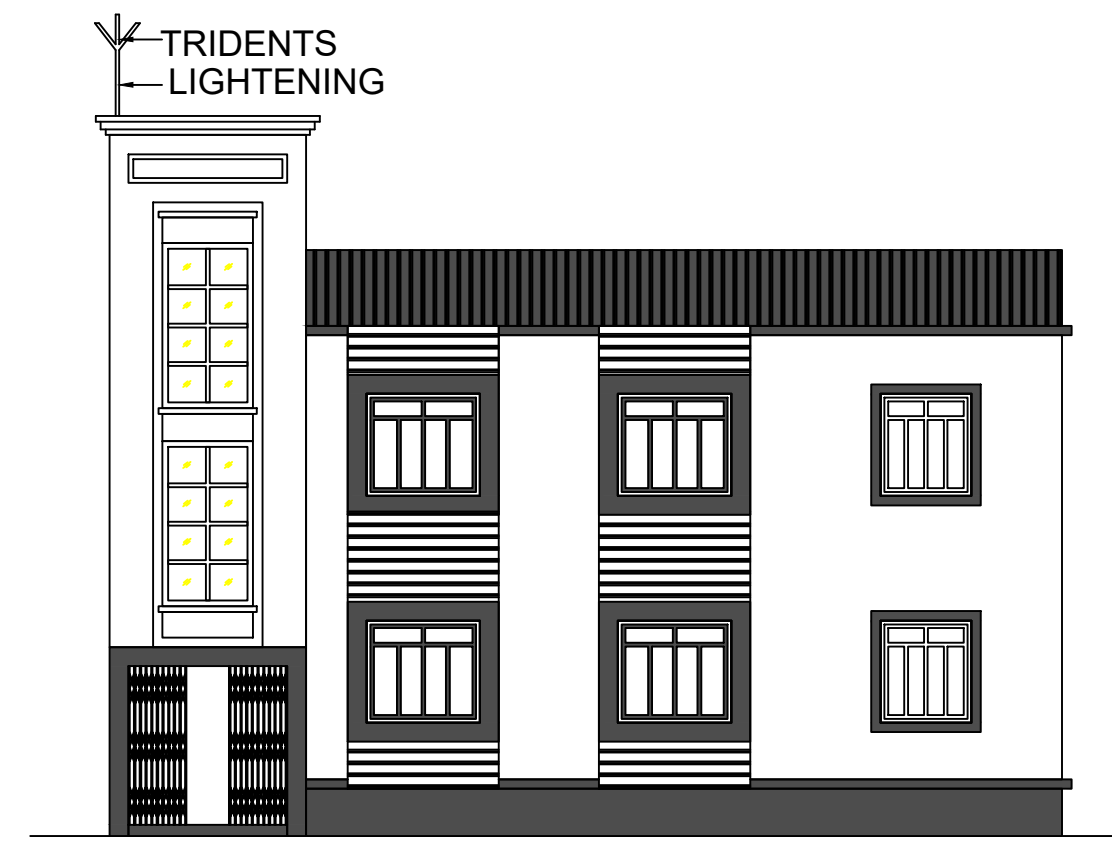

FRONT ELEVATION

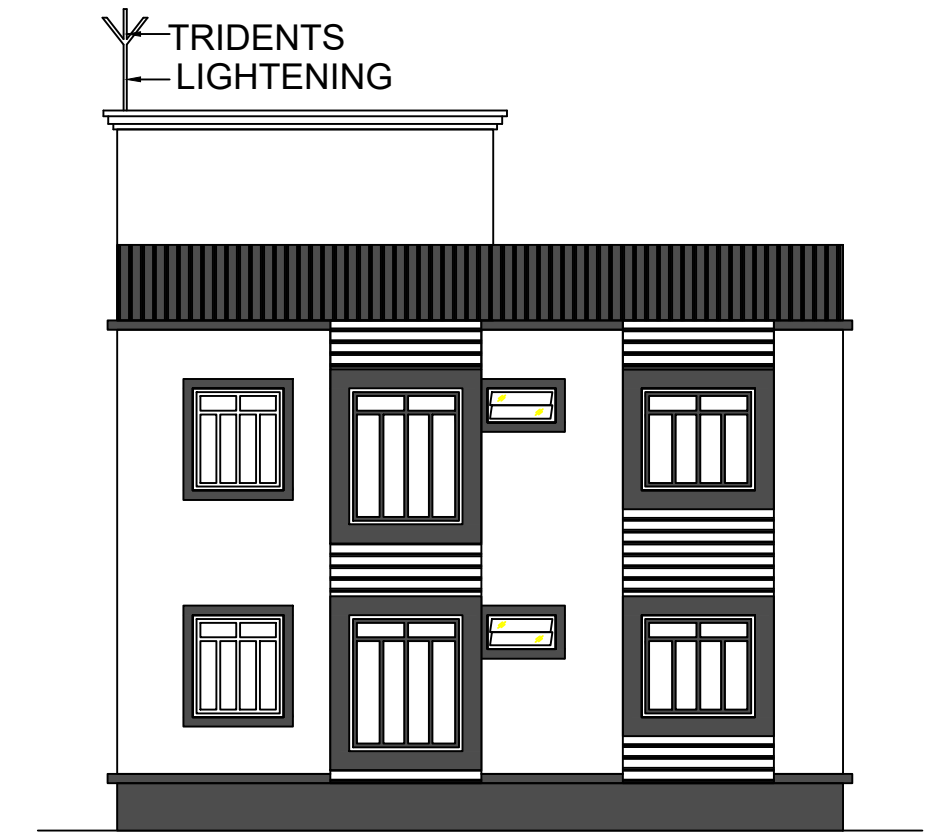

R.H.S. ELEVATION

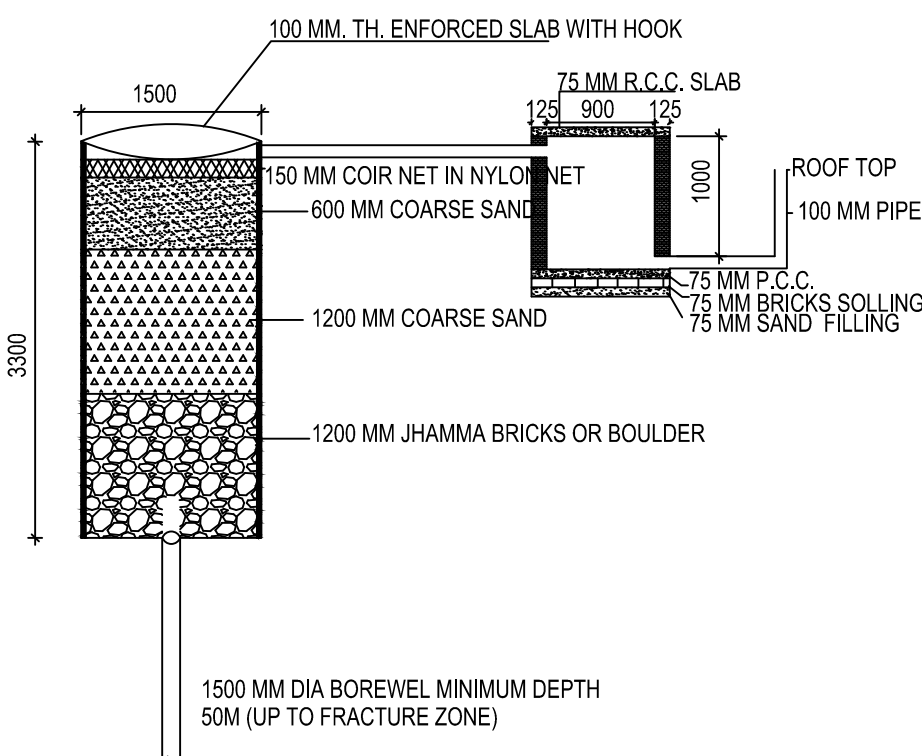

DETAIL OF GROUND WATER RECHARGING PIT WITH SILT TANK
SCALE - N.T.S.

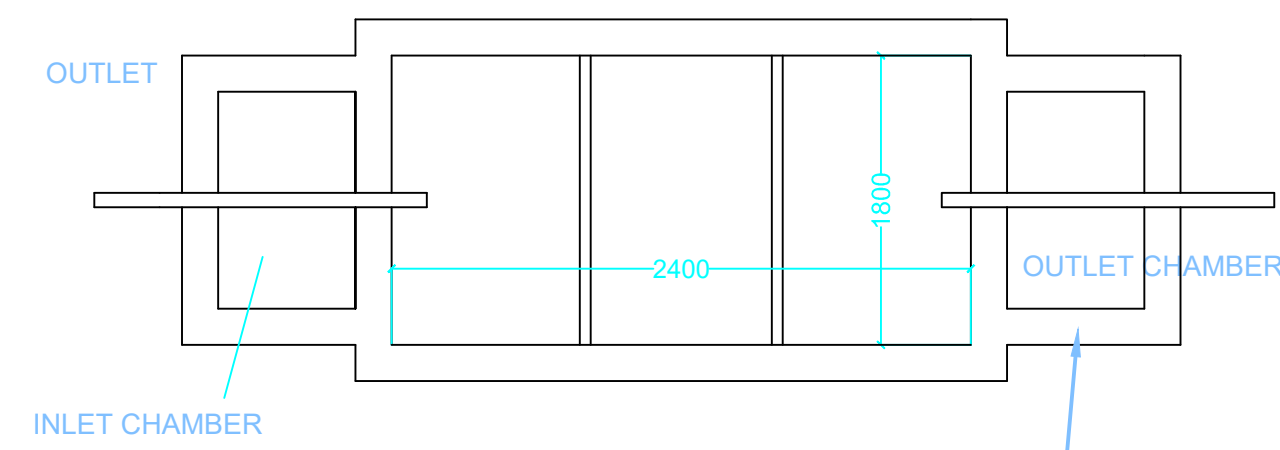

PLAN FOR SEPTIC TANK

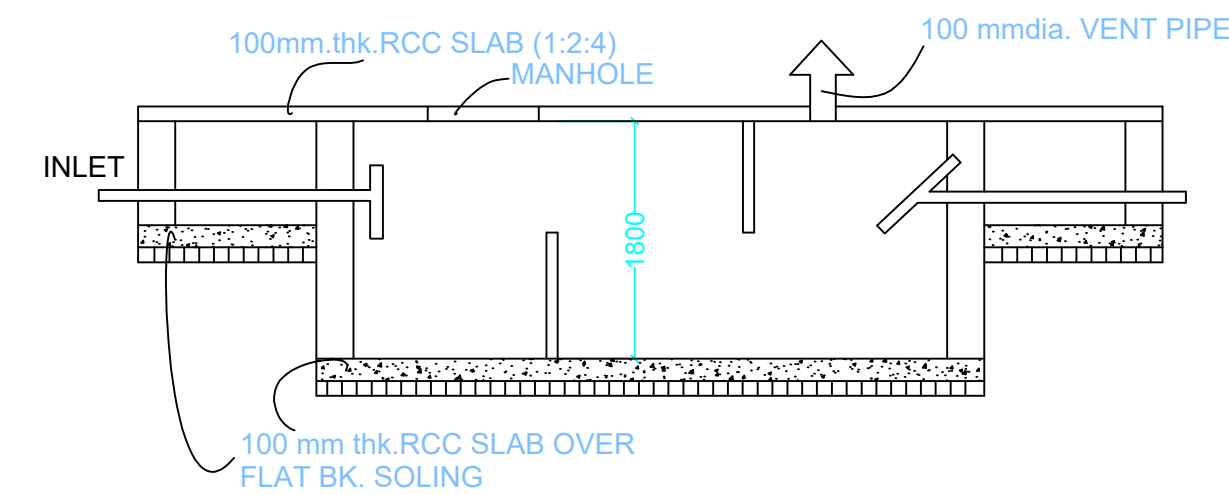

SECTION SCALE 1:50
SEPTIC TANK DETAILS

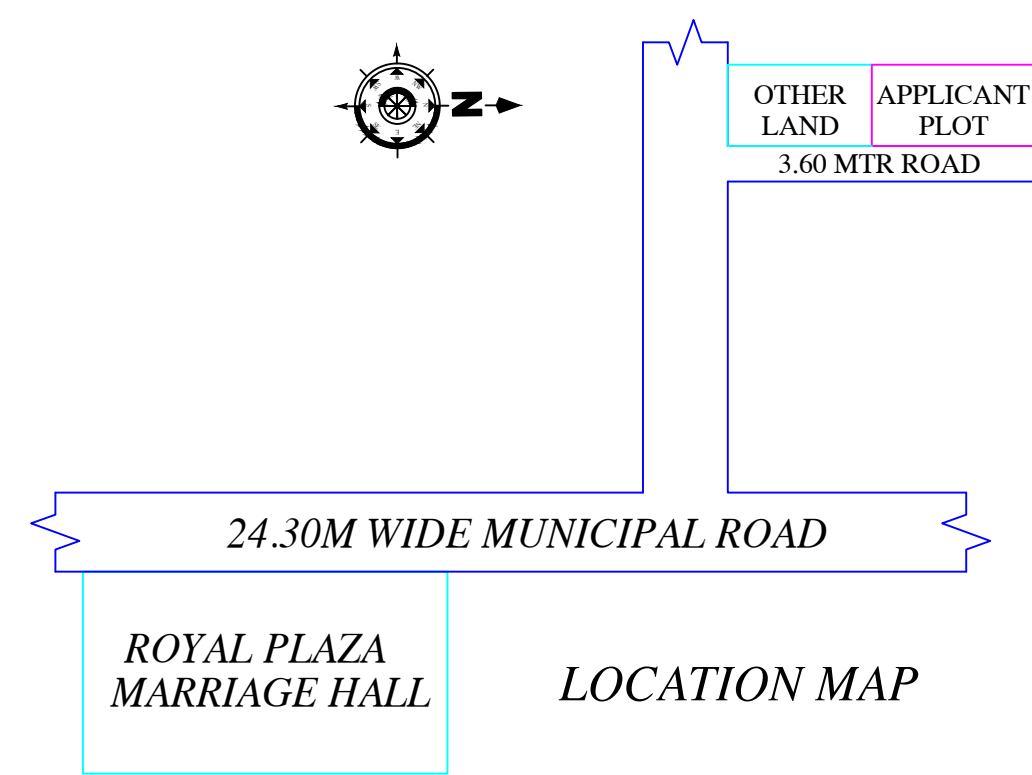

LOCATION MAP

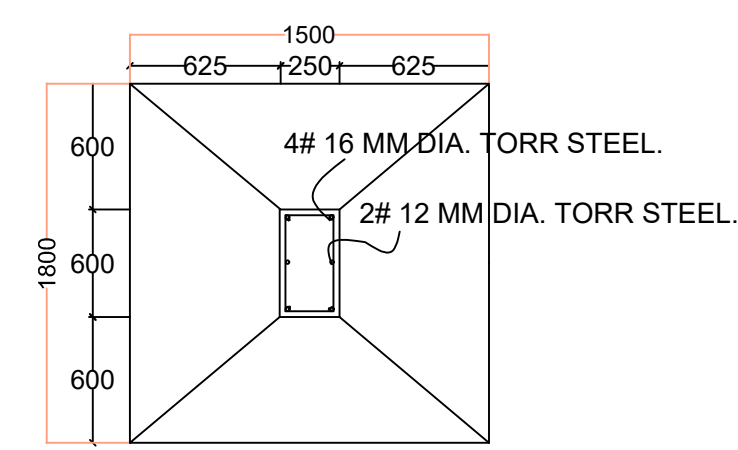

PLAN FOUNDATION DETAILS (ISOLATED R.C.C FOOTING)

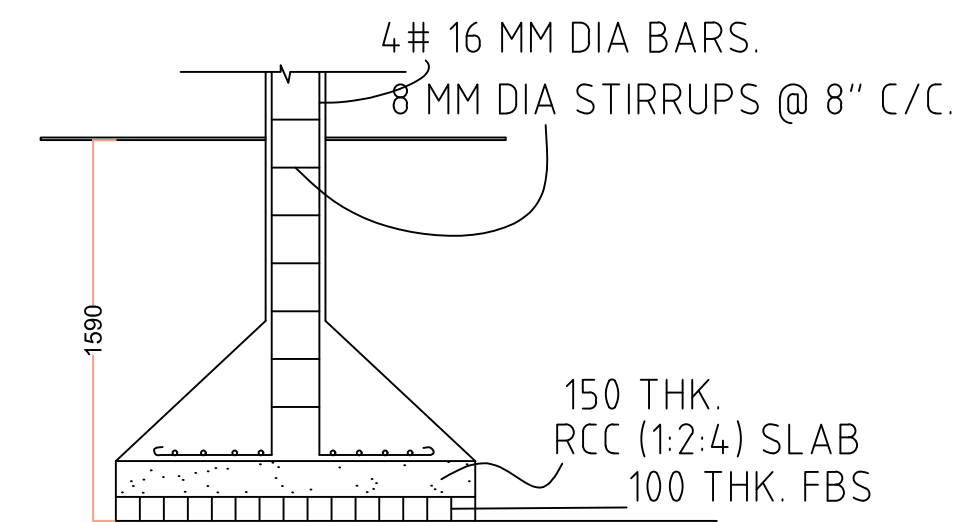

SECTION

LTP NAME AND SIGNATURE	STRUCTURAL ENG'S NAME AND SIGNATURE	BUILDER NAME AND SIGNATURE	DIGITAL SIGNATURE
RAJKISHOR KUMAR MNP/ENG/0003/2018			