

Proposal Basic Information

Proposal File No.	MNP/BI/0038/W21/2022
Owner Name	KUMAR SAURAV
Khata No	220/1
Plot No	0/1
Village Name	Patharchptti
Use	Residential
SubUse	Bungalow/ Dwelling / Non Apartment

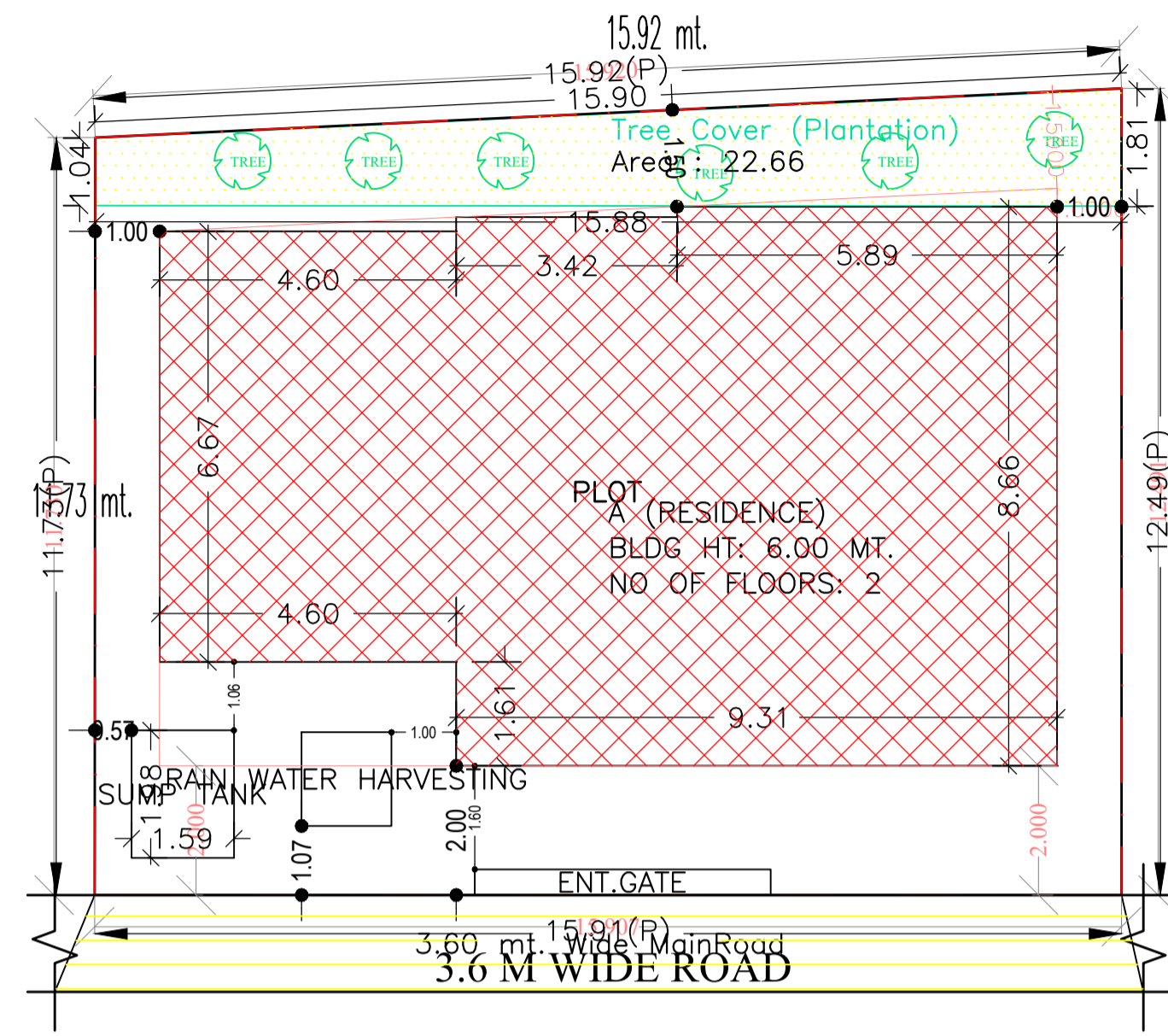

COLOR INDEX	
PLOT BOUNDARY	Black
ABUTTING ROAD	Green
PROPOSED CONSTRUCTION	Red
COMMON PLOT	Yellow
ROAD WIDENING AREA	Blue
EXISTING (To be retained)	Light Blue
EXISTING (To be demolished)	Light Yellow

SITE PLAN

site plan

Buildingwise Floor FAR Details

Floor Name	Building Name A (RESIDENCE)		Total	
	Proposed Built Up Area (Sq.mt.)	Proposed FAR Area (Sq.mt.)	Total Proposed Built Up Area (Sq.mt.)	Total FAR Area (Sq.mt.)
Ground Floor	110.68	110.68	110.68	110.68
First Floor	110.68	110.68	110.68	110.68
Terrace Floor	0.00	0.00	0.00	0.00
Total :	221.36	221.36	221.36	221.36

Building USE/SUBUSE Details

Building Name	Building Use	Building SubUse	Building Structure
A (RESIDENCE)	Residential	Bungalow/ Dwelling / Non Apartment	Non-Highrise

FAR & Tenement Details (Table 4c-1)

Building	No. of Same Bldg	Total Built Up Area (Sq.mt.)	Proposed FAR Area (Sq.mt.) Resi.	Total FAR Area (Sq.mt.)	Total Consumed Additional FAR Area (Sq.mt.)	Tnmt (No.)
A (RESIDENCE)	1	221.36	221.36	221.36	221.36	01
Grand Total :	1	221.36	221.36	221.36	221.36	01

AREA STATEMENT		VERSION NO.: 1.0.62
MADHUPUR NAGAR PARISHAD		VERSION DATE: 16/10/2020
PROJECT DETAIL:		
Region: JHARKHAND URBAN LOCAL BODIES	Plot Use: Residential	
District: DEOGHAR	Plot SubUse: Bungalow/ Dwelling / Non Apartment	
Authority: MADHUPUR NAGAR PARISHAD	PlotNearbyReligiousStructure: NA	
Inward_No: MNP/BI/0038/W21/2022	Plot/SubPlot No: 0/1	
Application Type: General Proposal	North: Plot No. - 35 AND 40	
Project Type: Building Permission	South: Road Width - 3.6	
Nature of Development: New	East: Plot No. - VENDORS LAND	
Location of Development Area: Old Area	West: Plot No. - VENDORS LAND	
AREA DETAILS:		
AREA OF PLOT (Minimum)	(A)	SQ.MT. 192.00
NET AREA OF PLOT (Gross Plot Area - Deduction from Gross Plot area)	(A-Deductions)	192.00
Deduction for Balance Plot Area(from Gross Plot Area)		
Common Plot		22.66
Total		22.66
BALANCE AREA OF PLOT (Net Plot Area - Recreational/Amenity space)	(A-Deductions)	169.34
PLOT AREA FOR COVERAGE (Net Plot Area)	(A-Deductions)	192.00
Plot Area for FAR (Net Plot Area + Road/Widening Area)	(A-Deductions)	192.00
COVERAGE CHECK		
Permissible Coverage area (70.00 %)		134.40
Proposed Coverage Area (57.66 %)		110.68
Total Prop. Coverage Area (57.66 %)		110.68
Balance coverage area (12.35 %)		23.72
FAR CHECK		
Perm. FAR Area (1.50)		288.00
Total Perm. FAR area		288.00
Residential FAR		221.35
Proposed FAR Area		221.35
Total Proposed FAR Area		221.35
Consumed FAR (Factor)		1.15
Balance FAR Area		66.65
BUILT UP AREA CHECK		
Total Proposed BuiltUp Area		221.36
ARCHITECT (Regd)	VISHAL YADAV	
ENGINEER (Regd)		
SUPERVISOR (Regd)		
OWNER (Regd)	KUMAR SAURAV	
DEVELOPMENT AUTHORITY		LOCAL BODY

LTP NAME AND SIGNATURE	STRUCTURAL ENG'S NAME AND SIGNATURE	BUILDER NAME AND SIGNATURE	DIGITAL SIGNATURE
VISHAL YADAV MNP/ENG/0006/2020			

Proposal Basic Information	
Proposal File No.	MNP/EP/0038/W21/2022
Owner Name	KUMAR SAURAV
Khata No	220/1
Plot No	0/1
Village Name	Patharchptti
Use	Residential
SubUse	Bungalow/ Dwelling / Non Apartment

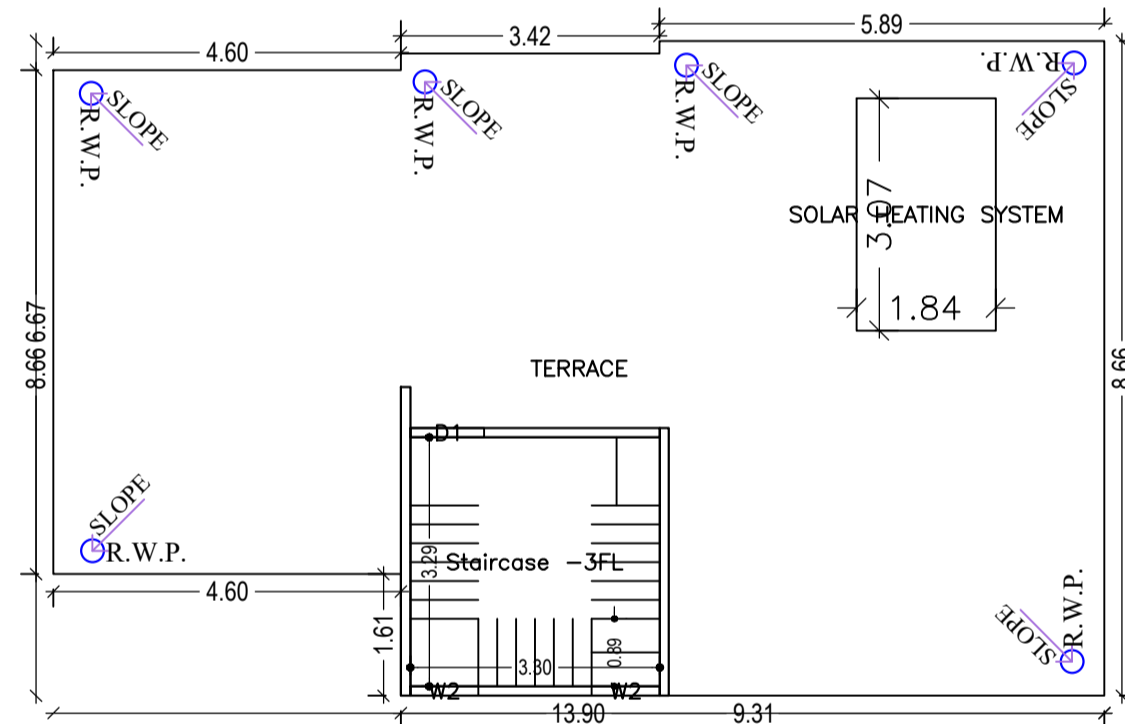
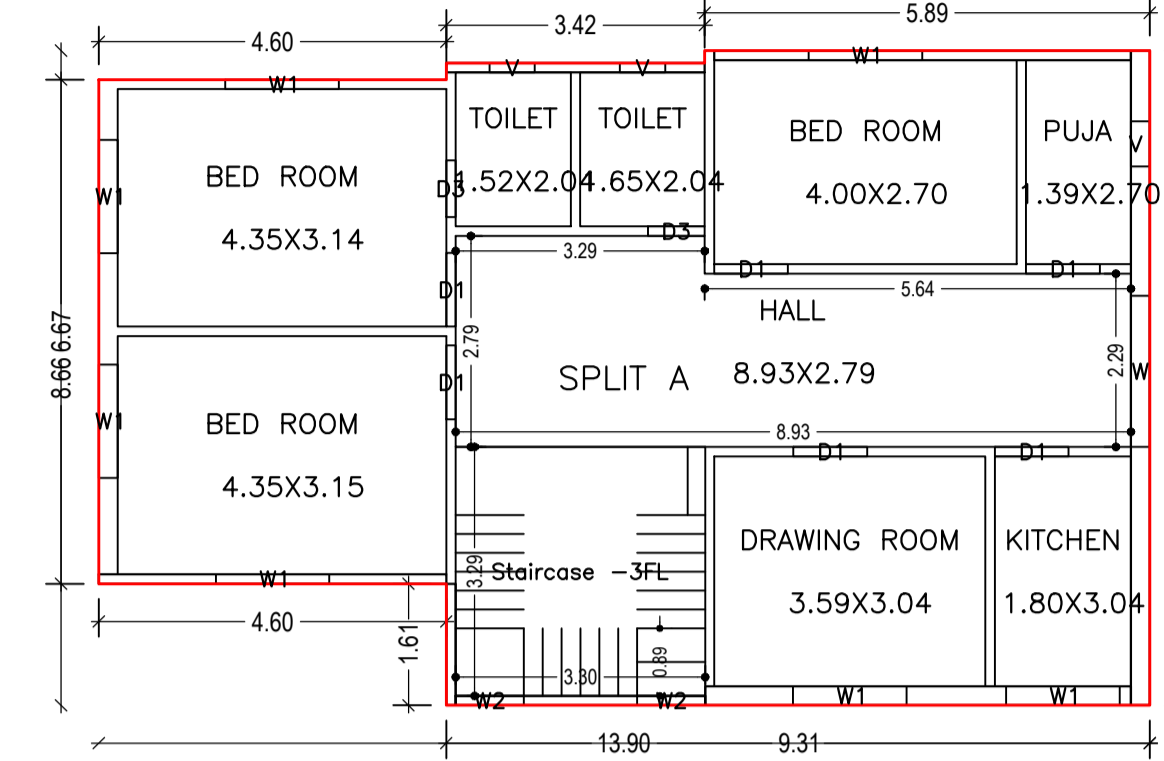
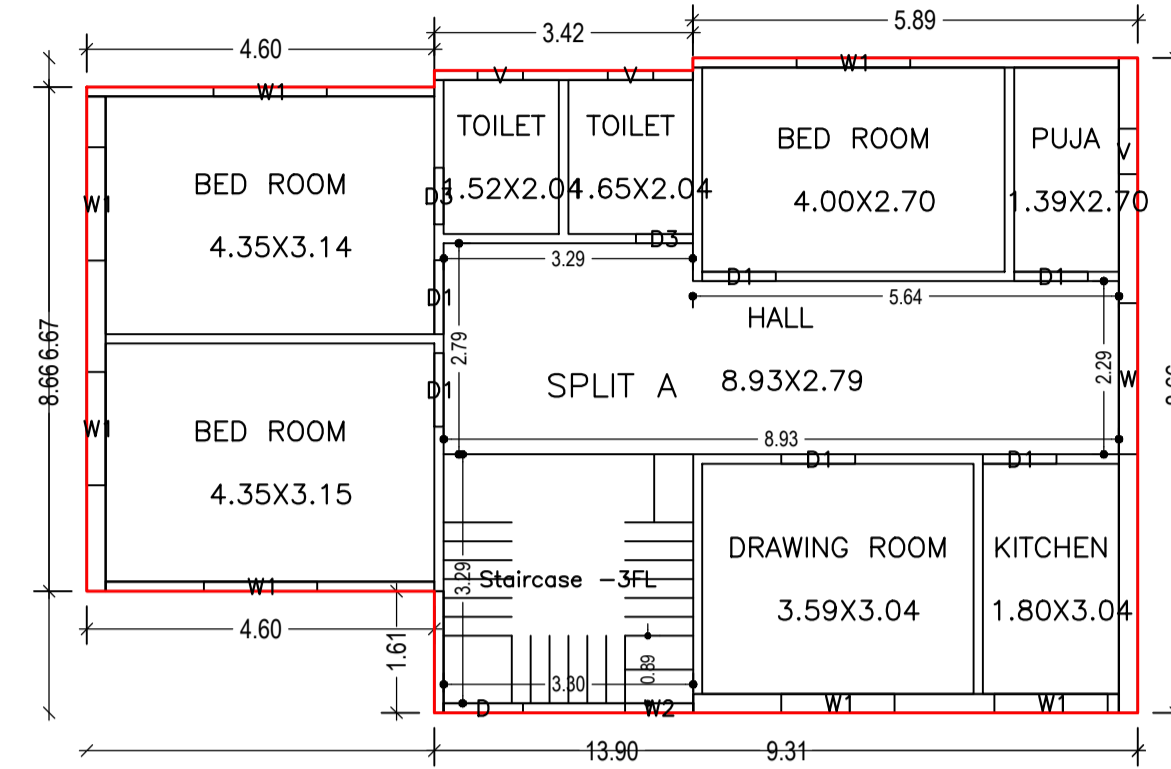
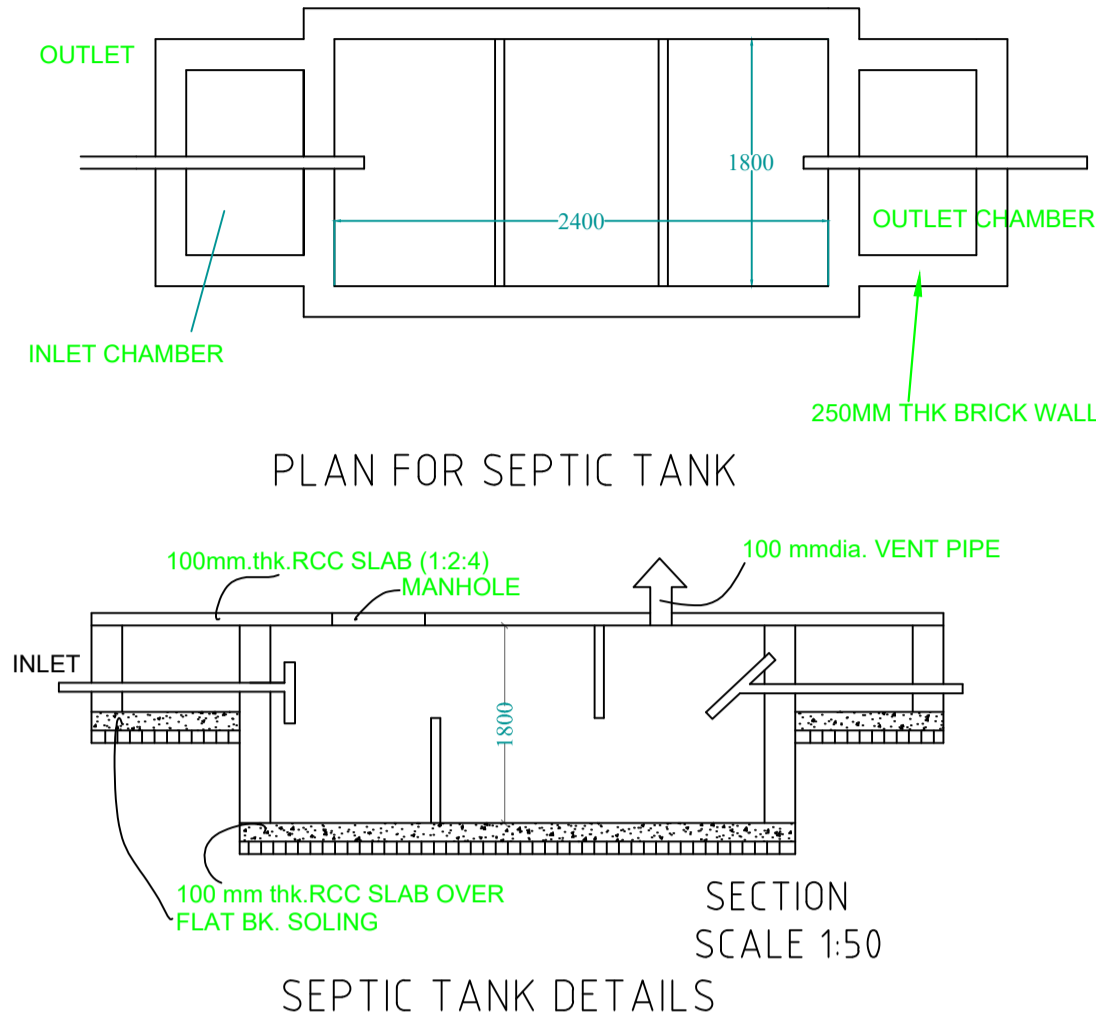

Building :A (RESIDENCE)

Floor Name	Total Built Up Area (Sq.mt.)	Proposed FAR Area (Sq.mt.) Resi.	Total FAR Area (Sq.mt.)	Total Consumed Additional FAR Area (Sq.mt.)	Tnmt (No.)
Ground Floor	110.68	110.68	110.68	110.68	01
First Floor	110.68	110.68	110.68	110.68	00
Terrace Floor	0.00	0.00	0.00	0.00	00
Total:	221.36	221.36	221.36	221.36	01
Total Number of Same Buildings	1				
Total:	221.36	221.36	221.36	221.36	01

SCHEDULE OF DOOR:

BUILDING NAME	NAME	LENGTH	HEIGHT	NOS
A (RESIDENCE)	D3	0.75	2.10	04
A (RESIDENCE)	D1	0.98	2.10	12

SCHEDULE OF WINDOW/VENTILATION:

BUILDING NAME	NAME	LENGTH	HEIGHT	NOS
A (RESIDENCE)	V	0.60	0.60	06
A (RESIDENCE)	W2	0.90	1.20	05
A (RESIDENCE)	W1	1.50	1.20	14
A (RESIDENCE)	W	2.00	1.20	02

UnitBUA Table for Building :A (RESIDENCE)

FLOOR	Name	UnitBUA Type	UnitBUA Area	Carpet Area	No. of Rooms	No. of Tenement
GROUND FLOOR PLAN	SPLIT A	FLAT	198.39	185.67	9	1
FIRST FLOOR PLAN	SPLIT A	FLAT	0.00	0.00	9	0
Total:	-	-	198.39	185.67	18	1

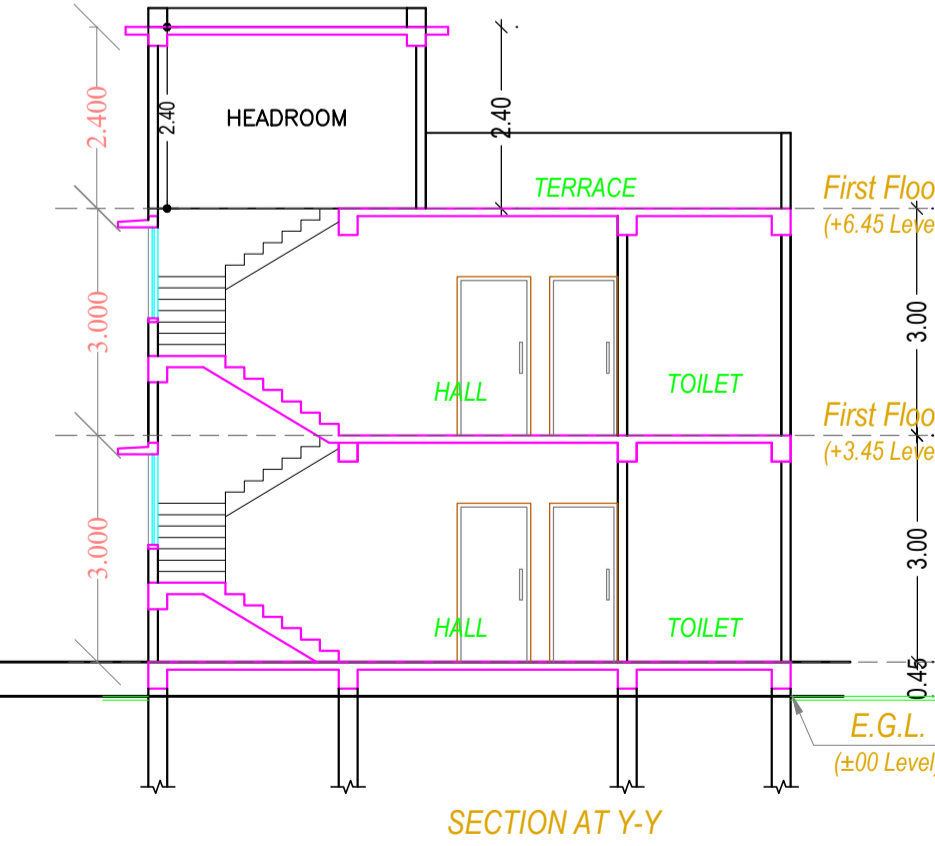
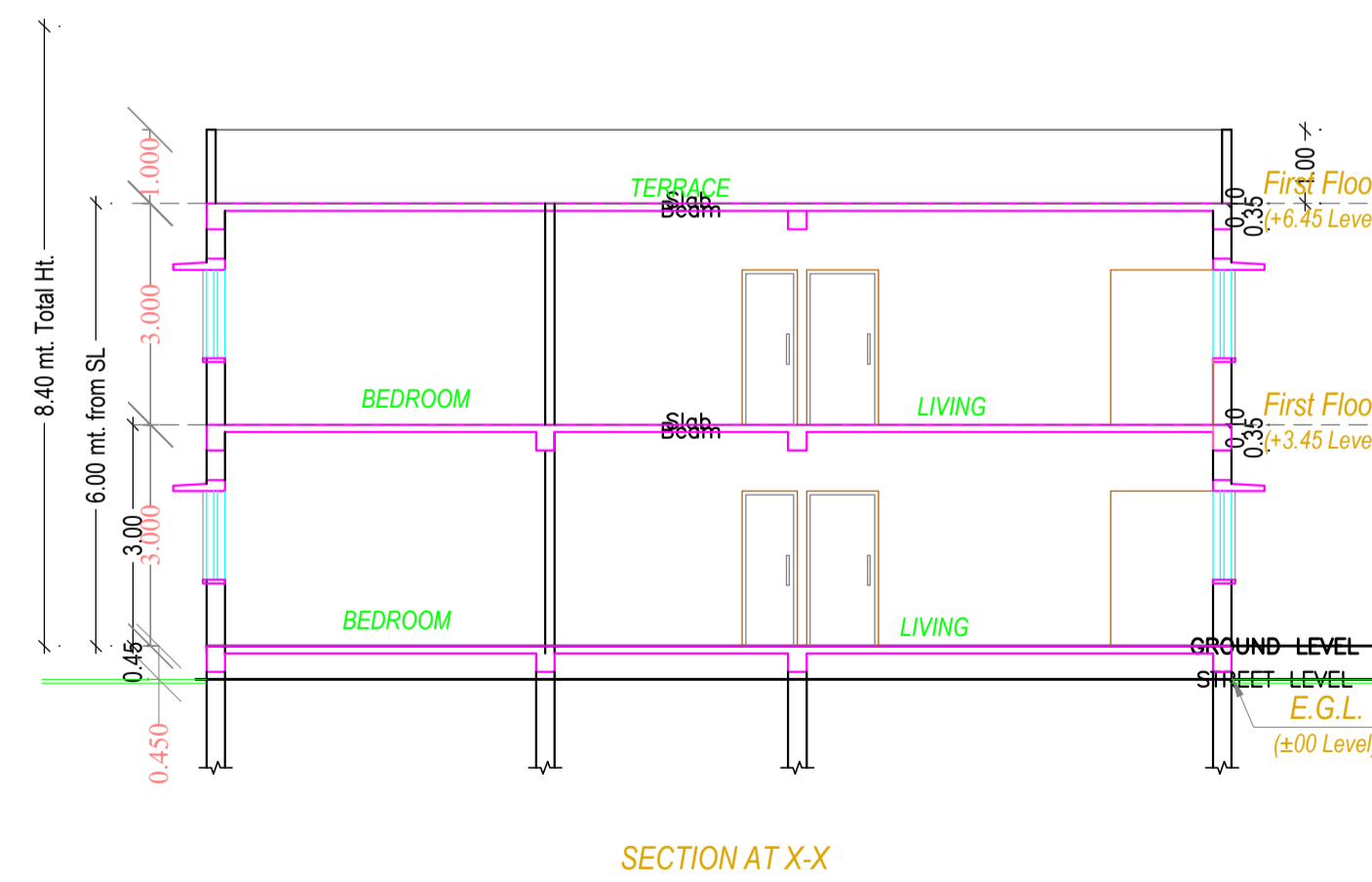

LTP NAME AND SIGNATURE	STRUCTURAL ENG'S NAME AND SIGNATURE	BUILDER NAME AND SIGNATURE	DIGITAL SIGNATURE
VISHAL YADAV MNP/ENG/0006/2020			

Proposal Basic Information	
Proposal File No.	MNP/BP/0038/W21/2022
Owner Name	KUMAR SAURAV
Khata No	220/1
Plot No	0/1
Village Name	Patharchptti
Use	Residential
SubUse	Bungalow/ Dwelling / Non Apartment

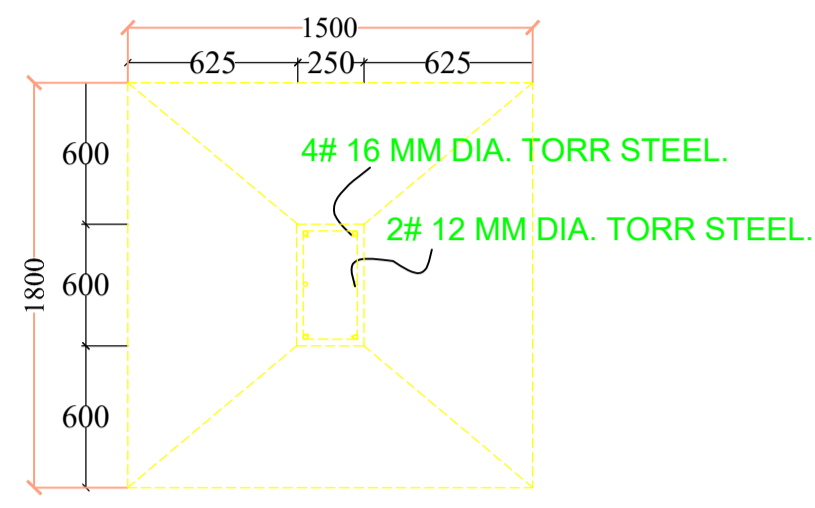

PLAN

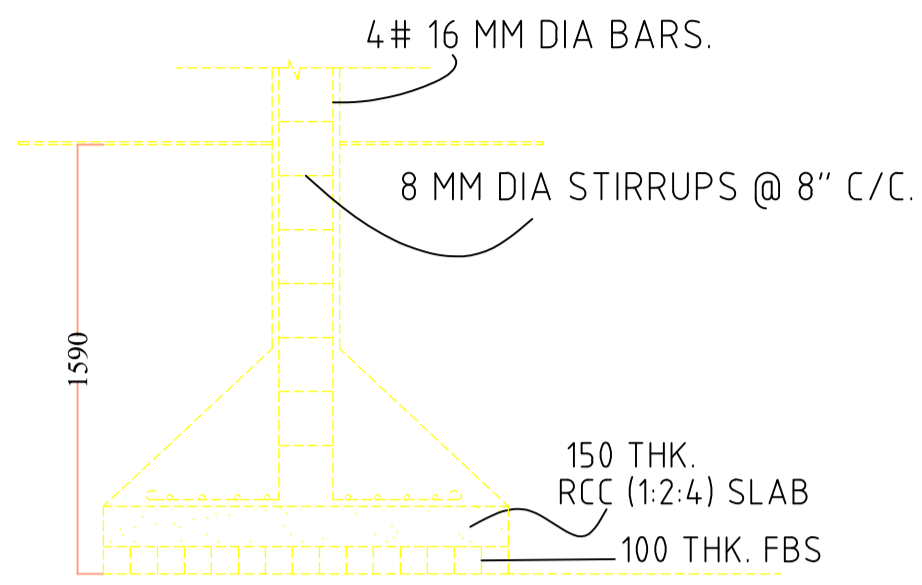

SECTION

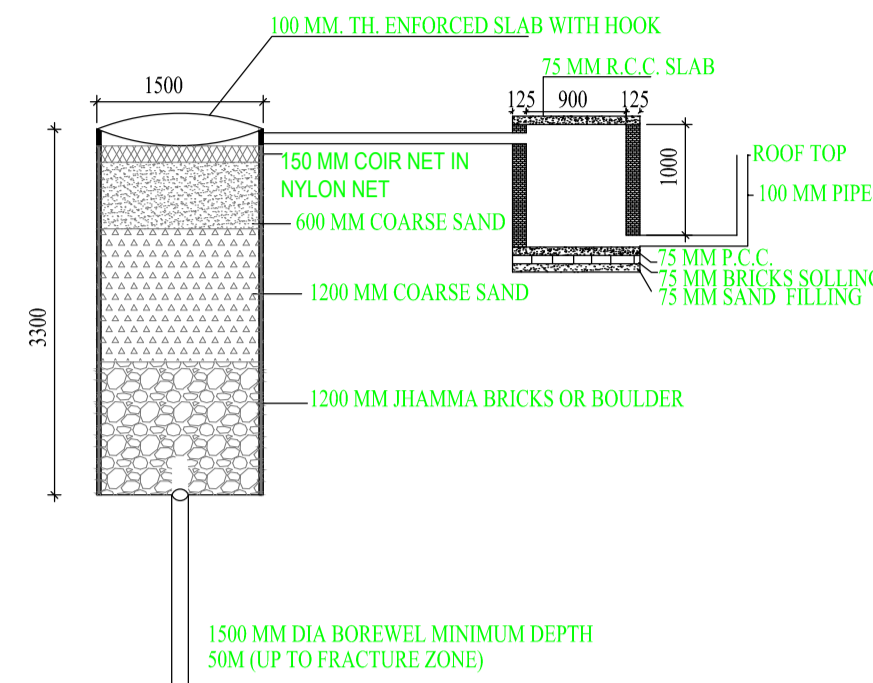

DETAIL OF GROUND WATER RECHARGING PIT WITH SILT TANK
SCALE - N.T.S.

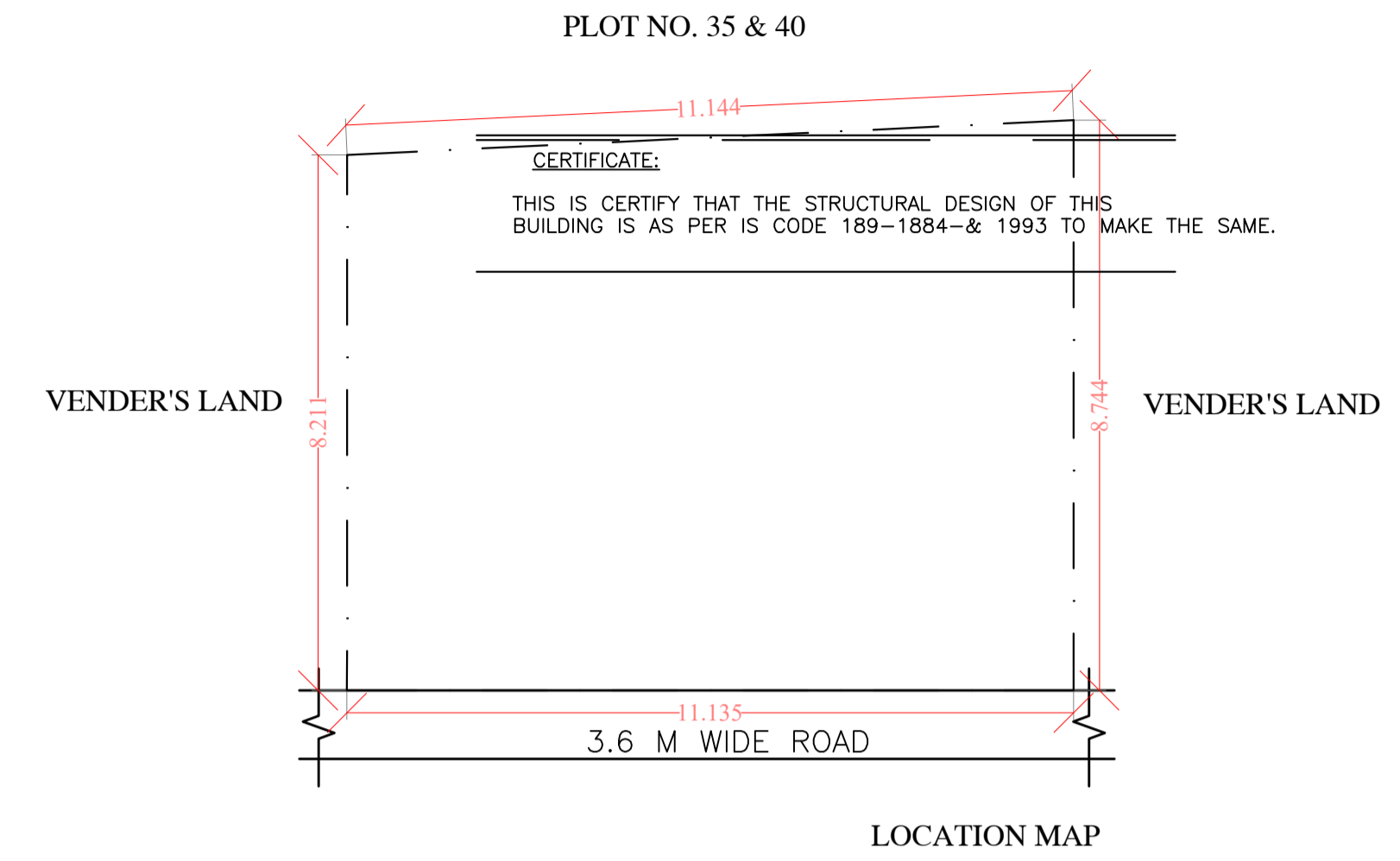

LOCATION MAP

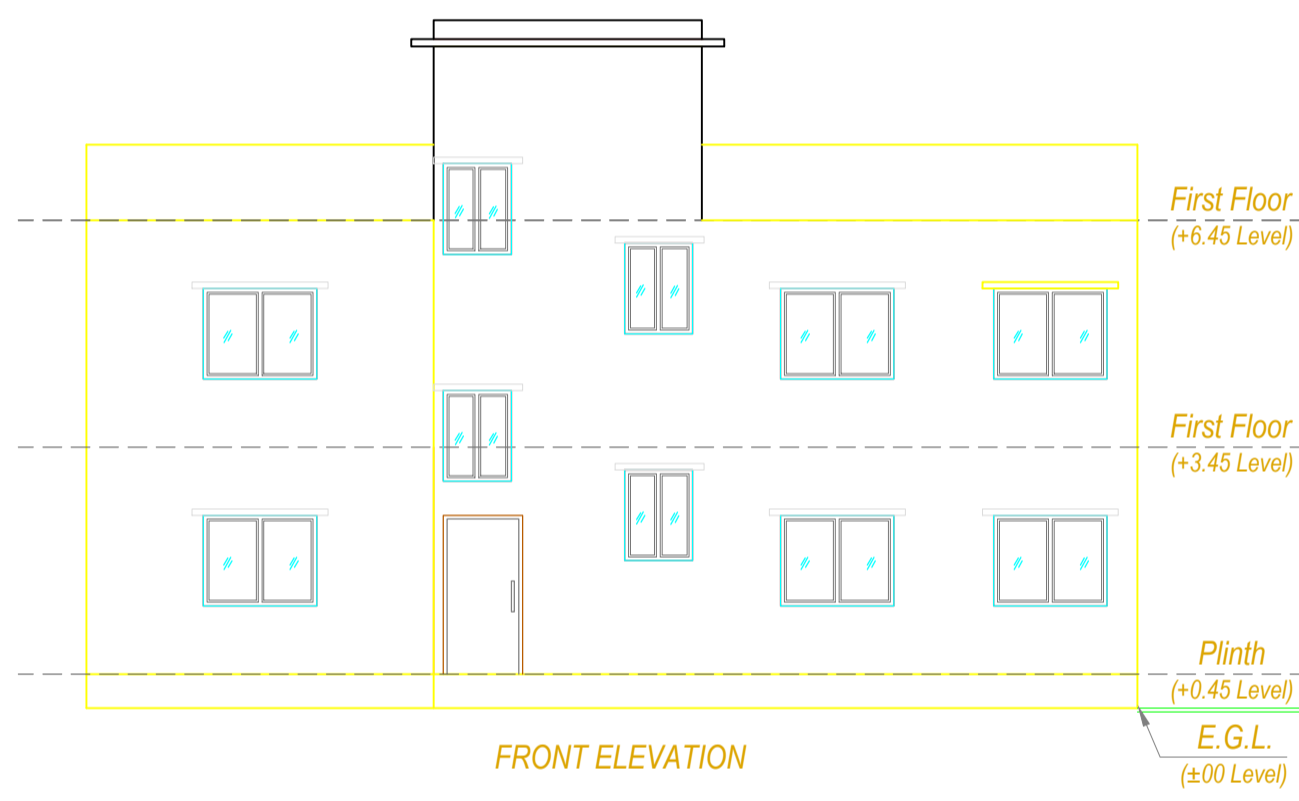

FRONT ELEVATION

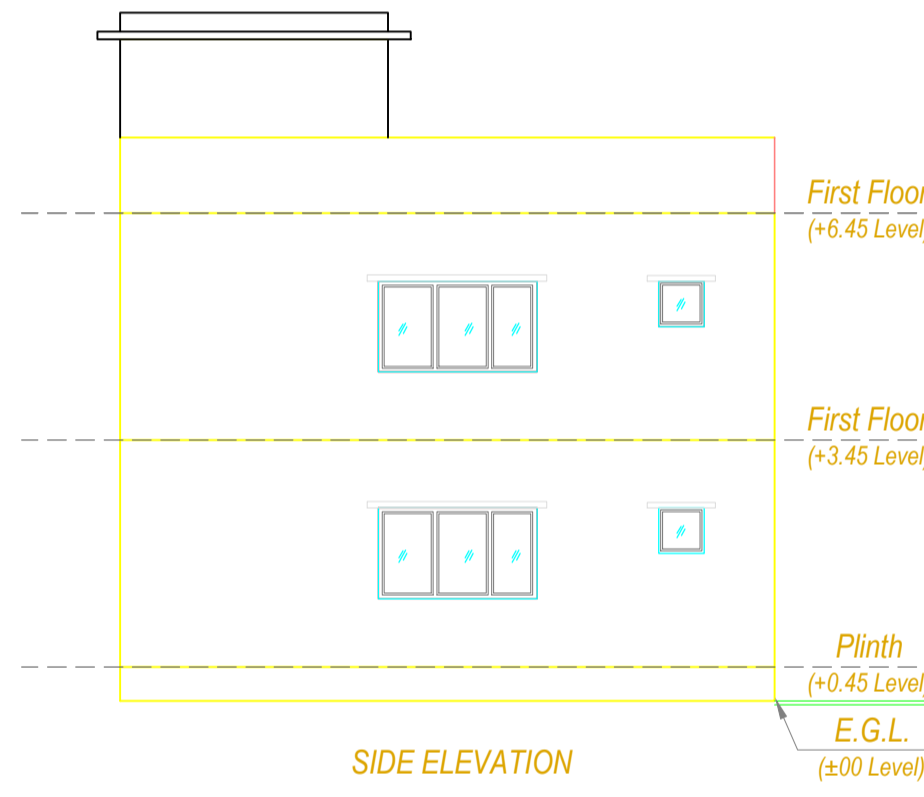

SIDE ELEVATION

LTP NAME AND SIGNATURE	STRUCTURAL ENG'S NAME AND SIGNATURE	BUILDER NAME AND SIGNATURE	DIGITAL SIGNATURE
VISHAL YADAV MNP/ENG/0006/2020			